



HAL
open science

Symmetric Disjunctive List-Decoding Codes

A.G. d'Yachkov, I.V. Vorobyev, N.A. Polyanskii, V.Yu. Shchukin

► **To cite this version:**

A.G. d'Yachkov, I.V. Vorobyev, N.A. Polyanskii, V.Yu. Shchukin. Symmetric Disjunctive List-Decoding Codes. WCC2015 - 9th International Workshop on Coding and Cryptography 2015, Apr 2015, Paris, France. hal-01275864

HAL Id: hal-01275864

<https://inria.hal.science/hal-01275864>

Submitted on 18 Feb 2016

HAL is a multi-disciplinary open access archive for the deposit and dissemination of scientific research documents, whether they are published or not. The documents may come from teaching and research institutions in France or abroad, or from public or private research centers.

L'archive ouverte pluridisciplinaire **HAL**, est destinée au dépôt et à la diffusion de documents scientifiques de niveau recherche, publiés ou non, émanant des établissements d'enseignement et de recherche français ou étrangers, des laboratoires publics ou privés.

Symmetric Disjunctive List-Decoding Codes

A.G. D'yachkov, I.V. Vorobyev, N.A. Polyanskii and V.Yu. Shchukin

Lomonosov Moscow State University, Moscow, Russia
agd-msu@yandex.ru, vorobyev.i.v@yandex.ru, nikitapolysky@gmail.com,
vpik@mail.ru

Abstract. In this paper, we consider *symmetric disjunctive list-decoding* (SLD) codes, which are a class of binary codes based on a *symmetric disjunctive sum* (SDS) of binary symbols. By definition, the SDS takes values from the ternary alphabet $\{0, 1, *\}$, where the symbol $*$ denotes “erasure”. Namely: SDS is equal to 0 (1) if all its binary symbols are equal to 0 (1), otherwise SDS is equal to $*$. The main purpose of this work is to obtain bounds on the rate of these codes.

Keywords: Symmetric disjunctive codes, random coding bounds, nonadaptive symmetric group testing.

1 Statement of Problem and Results

1.1 Notations and Definitions

Let N , t , s , and L be integers, where $2 \leq s < t$, $1 \leq L \leq t - s$. Let \triangleq denote the equality by definition, $|A|$ – the size of the set A and $[N] \triangleq \{1, 2, \dots, N\}$ – the set of integers from 1 to N . The standard symbol $\lfloor a \rfloor$ will be used to denote the largest integer $\leq a$.

A binary $(N \times t)$ -matrix $X = \|x_i(j)\|$, $x_i(j) = 0, 1$, with N rows $\mathbf{x}_i \triangleq (x_i(1), \dots, x_i(t))$, $i \in [N]$, and t columns $\mathbf{x}(j) \triangleq (x_1(j), \dots, x_N(j))$, $j \in [t]$, (codewords) is called a *binary code of length N and size $t = \lfloor 2^{RN} \rfloor$* , where a fixed parameter $R > 0$ is called a *rate* of the code X . The number of 1's in the codeword $x(j)$, i.e., $|\mathbf{x}(j)| \triangleq \sum_{i=1}^N x_i(j)$, is called a *weight* of $x(j)$, $j \in [t]$. A code X is called a *constant weight binary code of weight w* , $1 \leq w < N$, if for any $j \in [t]$, the weight $|\mathbf{x}(j)| = w$.

Let $\mathbf{u} \vee \mathbf{v}$ denote the disjunctive sum of binary columns $\mathbf{u}, \mathbf{v} \in \{0, 1\}^N$. If $\mathbf{x}, \mathbf{y} \in \{0, 1, *\}^N$ are arbitrary *ternary* columns with components from the alphabet $\{0, 1, *\}$, then the ternary column $\mathbf{z} = (z_1, z_2, \dots, z_N) \in \{0, 1, *\}^N$,

$$z_i \triangleq \begin{cases} 0, & \text{if } x_i = y_i = 0, \\ 1, & \text{if } x_i = y_i = 1, \\ *, & \text{otherwise,} \end{cases}$$

is called a *symmetric disjunctive sum* [1] of \mathbf{x} and \mathbf{y} . This operation will be denoted by ∇ , that is $\mathbf{z} = \mathbf{x} \nabla \mathbf{y}$. We say that a binary column \mathbf{u} covers a column \mathbf{v} ($\mathbf{u} \succeq \mathbf{v}$) if $\mathbf{u} \vee \mathbf{v} = \mathbf{u}$, and a ternary column \mathbf{u} *symmetrically covers* a column \mathbf{v} ($\mathbf{u} \succeq \mathbf{v}$) if $\mathbf{u} \nabla \mathbf{v} = \mathbf{u}$.

1.2 Symmetric Disjunctive List-Decoding Codes (SLD s_L -codes)

Definition 1. [2, 3]. A binary code X is said to be a *disjunctive list-decoding code of strength s with list size L* (LD s_L -code) if the disjunctive sum of any s codewords of X covers not more than $L - 1$ other codewords of X that are not components of the given sum. In other words, for any two disjoint sets $\mathcal{S}, \mathcal{L} \subset [t], |\mathcal{S}| = s, |\mathcal{L}| = L, \mathcal{S} \cap \mathcal{L} = \emptyset$, there exist a row $\mathbf{x}_i, i \in [N]$, and a column $\mathbf{x}(j), j \in \mathcal{L}$, such that

$$x_i(k) = 0 \quad \forall k \in \mathcal{S} \quad \text{and} \quad x_i(j) = 1.$$

Denote by $t_{ld}(N, s, L)$ the maximal size of LD s_L -codes of length N and by $N_{ld}(t, s, L)$ the minimal length of LD s_L -codes of size t . Define the *rate* of LD s_L -codes:

$$R_L(s) \triangleq \overline{\lim}_{N \rightarrow \infty} \frac{\log_2 t_{ld}(N, s, L)}{N} = \overline{\lim}_{t \rightarrow \infty} \frac{\log_2 t}{N_{ld}(t, s, L)}. \quad (1)$$

Definition 2. [4–6]. A binary code X is said to be a *symmetric disjunctive list-decoding code of strength s with list size L* (SLD s_L -code) if the symmetric disjunctive sum of any s codewords of X symmetrically covers not more than $L - 1$ other codewords of X that are not components of the given sum. In other words, for any two disjoint sets $\mathcal{S}, \mathcal{L} \subset [t], |\mathcal{S}| = s, |\mathcal{L}| = L, \mathcal{S} \cap \mathcal{L} = \emptyset$, there exist a row $\mathbf{x}_i, i \in [N]$, and a column $\mathbf{x}(j), j \in \mathcal{L}$, such that

$$\begin{aligned} x_i(k) = 0 \quad \forall k \in \mathcal{S} \quad \text{and} \quad x_i(j) = 1, \quad \text{or} \\ x_i(k) = 1 \quad \forall k \in \mathcal{S} \quad \text{and} \quad x_i(j) = 0. \end{aligned}$$

Denote by $t_{sld}(N, s, L)$ the maximal size of SLD s_L -codes of length N and by $N_{sld}(t, s, L)$ the minimal length of SLD s_L -codes of size t . Define the *rate* of SLD s_L -codes:

$$R_L^*(s) \triangleq \overline{\lim}_{N \rightarrow \infty} \frac{\log_2 t_{sld}(N, s, L)}{N} = \overline{\lim}_{t \rightarrow \infty} \frac{\log_2 t}{N_{sld}(t, s, L)}. \quad (2)$$

Remark 1. An SLD s_1 -code is the special case of separating codes [7]. More specifically, for $L = 1$, Definition 2 coincides with the definition of $(s, 1)$ -separating code with the alphabet size $q = 2$. Some results and applications of $(s, 1)$ -separating binary codes are presented in the survey [8].

Theorem 1. (Monotonicity properties). *The rate of SLD s_L -codes satisfies the following inequalities*

$$R_L^*(s + 1) \leq R_L^*(s) \leq R_{L+1}^*(s). \quad (3)$$

Proof of Theorem 1. It immediately follows from Definition 2 that every SLD $(s+1)_L$ -code is the corresponding SLD s_L -code, so the left inequality in (3) takes place. Simultaneously, every SLD s_L -code is SLD s_{L+1} -code, therefore the right inequality in (3) is true. \square

1.3 Applications of Symmetric Disjunctive Codes

Applications of SLD s_L -codes relate to the *non-adaptive symmetric group testing* which is based on the symmetric disjunctive sum of binary symbols. Group testing deals with identification of defective units in a given pool. We use symmetric group tests, i.e., take a subset of the pool and check it. The outcome of a symmetric group test belongs to the ternary alphabet. It is equal to 0, 1 or *, if all tested units are not defective, all units are defective or at least one unit is defective and at least another one is not defective, respectively. The symmetric group testing was motivated by applications [1] in electrical devices testing and chemical analysis.

Suppose the size of the pool equals t and the number of defected units does not exceed s . As is the case with LD s_L -codes [9], SLD s_L -codes can be considered in connection with the problem of constructing *two-stage non-adaptive symmetric group testing procedures*. In the first stage, one does N tests that can be depicted as an binary $(N \times t)$ -matrix $X = \|x_i(j)\|$, where a column $\mathbf{x}(j)$ corresponds to the j -th unit, a row \mathbf{x}_i corresponds to the i -th test and $x_i(j) \triangleq 1$ if and only if the j -th unit is included into the i -th testing group. Then the ternary column y of the test results equals the symmetric disjunctive sum of the columns which correspond to the defective units. Let X be SLD s_L -code, after decoding of the result column y , i.e. search of codewords which are symmetrically covered by y , a set of $\leq s + L - 1$ elements is selected. These units are separately tested in the second stage.

In papers [4, 5], we suggested another application of SLD codes called *reference communication system*. Let a system contain M terminal stations S_1, \dots, S_M and let a *multiple-access channel* (MAC) connect these M stations to a *central station* (CS). Each terminal station has a *source*. In every time interval, the source can produce a binary *information packet* of length K . Introduce $t \triangleq 2^K$ and enumerate all 2^K possible information packets by integers from 1 to t . The packets are encoded into binary sequences of length N by a code $X = (\mathbf{x}(i), i \in [t])$, where the codeword $\mathbf{x}(i), i \in [t]$, is the encoded sequence corresponding to the information packet number i . Denote by \mathcal{S} the set of numbers of generated packets and suppose $|\mathcal{S}| \leq s$.

The CS is interested only in the contents of the received packet and not in the senders. Using a *feedback broadcast channel* (FBC) the CS answers all M stations to all requests. The model of MAC corresponds to the *frequency modulation*, i.e., the output ternary sequence \mathbf{y} is the symmetric disjunctive sum of the inputs. The scheme of reference communication system is represented on Figure 1.

Let the terminal stations use an SLD s_L -code X . Since the number of information packets produced by the terminal stations in the same time interval

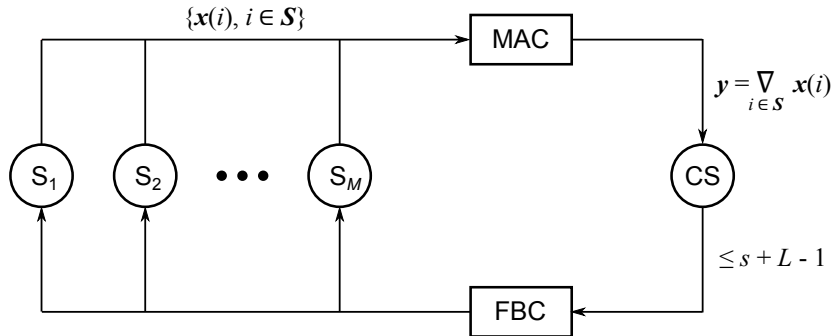

Fig. 1. Reference communication system

is not more than s , the CS is able to recover at most $s + L - 1$ packets, which contain s transmitted packets.

Note that the model of MAC can also correspond to the *impulse modulation*, i.e., the output binary sequence is the disjunctive sum of the inputs. In this case, it is convenient to use LD s_L -codes for encoding and decoding information packets. The case of impulse modulation was considered in [5].

Another application of SLD s_1 -codes concerns with *undetermined data* [10, 11]. Given an alphabet $A = \{a_1, a_2, \dots, a_t\}$ of *basic symbols*, to every nonempty subset $T \subseteq [t]$, assign a symbol a_T , which is called *undetermined*. Its *specification* is any basic symbol $a_i, i \in T$. By a *specification* of a sequence of undetermined symbols we mean the result of replacing all its symbols by some of its specifications. The symbol $a_{[t]}$ that can be specified by any basic symbol is called *indefinite* and is denoted by $*$. Let \mathcal{T} be a system of subsets $T \subseteq [t]$ and let $A^* = A_{\mathcal{T}}^* = \{a_T | T \in \mathcal{T}\}$ be an *undetermined alphabet* associated with the system.

Consider a problem of coding of undetermined sequences such that the original undetermined sequence can be completely reconstructed from the encoded sequence. One coding method refers to a *binary representation* [10, 11] of undetermined alphabet, which is defined as a pair (X, X^*) of $(N \times t)$ -matrix X with columns $\mathbf{x}(i) \in \{0, 1\}^N, i \in [t]$, and $(N \times |\mathcal{T}|)$ -matrix X^* with columns $\mathbf{x}(T) \in \{0, 1, *\}^N, T \in \mathcal{T}$, where $\mathbf{x}(i)$ specifies $\mathbf{x}(T)$ in undetermined alphabet $\{0, 1, *\}$ if and only if $i \in T$. Advantages of such method are linear in t complexity of the symbol reconstruction and the fact that the mentioned condition allows to know only a small matrix X for reconstruction of the original undetermined sequence while the matrix X^* may contain up to 2^t columns. Obviously, an SLD s_1 -code $X = (\mathbf{x}(i), i \in [t])$ and the matrix $X^* = (\bigvee_{i \in T} \mathbf{x}(i), T \in \mathcal{T})$ give the fairly compact binary representation of undetermined alphabet associated with the system $\mathcal{T} = [t] \cup \{T \subset [t] | |T| \leq s\}$ [11].

1.4 Relations Between Parameters of LD s_L -Codes and SLD s_L -Codes

The following evident propositions from [4–6] associate the rate of LD s_L -codes (1) with the rate of SLD s_L -codes (2).

Proposition 1. [4–6]. *Any LD s_L -code is the corresponding SLD s_L -code.*

Proposition 2. [4–6]. *Let $X = \|x_i(j)\|$ be an SLD s_L -code of length N and size t . Consider $(N \times t)$ -matrix $X' = \|x'_i(j)\|$ with elements*

$$x'_i(j) \triangleq \begin{cases} 1, & \text{if } x_i(j) = 0, \\ 0, & \text{if } x_i(j) = 1. \end{cases}$$

Then the code of length $2N$ and size t composed of all rows of the codes X and X' is an LD s_L -code.

Corollary 1. [4–6]. *The rates of LD s_L -codes and SLD s_L -codes satisfy inequalities:*

$$R_L(s) \leq R_L^*(s) \leq 2R_L(s). \quad (4)$$

The next obvious proposition allows us to get another upper bound on the rate of SLD s_L -codes.

Proposition 3. *Let X be an LD s_L -code of length N and size t with a codeword $\mathbf{x}(j_0)$ of weight w . Then the code X'' of length $N - w$ and size $t - 1$ constructed from the code X by removing the codeword $\mathbf{x}(j_0)$ and all rows x_i , for which $x_i(j_0) = 1$, is an LD $(s - 1)_L$ -code.*

Corollary 2. *The rate of SLD s_L -codes has the following upper bound:*

$$R_L^*(s) \leq R_L(s - 1). \quad (5)$$

Proof of Corollary 2. Let X be an arbitrary SLD s_L -code of length N and size t . The code X_1 obtained in Proposition 2 from the code X is a constant weight LD s_L -code of length $2N$, size t and weight N . Then the code X_2 obtained in Proposition 3 from the code X_1 is an LD $(s - 1)_L$ -code of length N and size $t - 1$. Hence as $N \rightarrow \infty$ the inequality

$$\frac{\log_2[t - 1]}{N} \leq R_L(s - 1)(1 + o(1))$$

holds. It means correctness of (5). \square

The best presently known lower and upper bounds on the rate $R_L(s)$ were recently obtained in [12, 13]. The use of the inequalities (4) and (5), the lower bound $\underline{R}_L(s)$ [12] and the upper bound $\overline{R}_L(s)$ [12] on the rate of LD s_L -codes yields the results below.

Theorem 2. (Relationship between $R_L^*(s)$ and $R_L(s)$)

The following three statements hold.

1. *For any fixed $s \geq 2$ and $L \geq 1$ the rates $R_L^*(s)$ and $R_L(s)$ have relationship*

$$R_L(s) \leq R_L^*(s) \leq \min\{2R_L(s), R_L(s - 1)\}.$$

2. For any fixed $L \geq 1$ and $s \rightarrow \infty$

$$R_L^*(s) = R_L(s)(1 + o(1)).$$

3. For any fixed $s \geq 2$ and $L \geq 1$ the rate of an SLD s_L -code satisfies the inequality

$$\underline{R}_L(s) \leq R_L^*(s) \leq \overline{R}_L^*(s) \triangleq \min\{2\overline{R}_L(s), \overline{R}_L(s-1)\}.$$

1.5 Random Coding Bounds on the Rate of SLD s_L -codes

In the given paper, we develop a random coding method based on the ensemble of constant-weight codes and establish new lower random coding bounds on the rate of SLD s_L -codes. Some of the methods which are used in the proof of the next theorem are presented in [12, 13].

Theorem 3. (Lower random coding bound $\underline{R}_L^*(s)$).

The following three statements hold.

1. For any fixed $L \geq 1$ and $s \geq 2$ we have the inequality

$$R_L^*(s) \geq \underline{R}_L^*(s) \triangleq \max_{0 < Q \leq 1/2} \left(h(Q) + \frac{B_L(s, Q)}{s + L - 1} \right), \quad (6)$$

where

$$\begin{aligned} h(Q) &\triangleq -Q \log_2 Q - (1 - Q) \log_2 [1 - Q], \\ B_L(s, Q) &\triangleq Q \log_2 \left[\frac{p(1 - z)}{p(1 - z) + q(1 - z)} \right] + (1 - Q) \log_2 \left[\frac{p(z)}{p(z) + q(z)} \right], \\ p(z) &\triangleq z^s (z - z^s)^L, \\ q(z) &\triangleq (z - z^s)(1 - z^s - (1 - z)^s)^L, \end{aligned} \quad (7)$$

and z is the unique root of the equation

$$Q(p(z) + q(z)) = (1 - Q)(p(1 - z) + q(1 - z)). \quad (8)$$

2. For fixed $L = 1, 2, \dots$ and $s \rightarrow \infty$

$$\underline{R}_L^*(s) \geq \frac{L}{s^2 \log_2 e} (1 + o(1)). \quad (9)$$

3. For fixed $s = 2, 3, \dots$ there exists a limit

$$\underline{R}_\infty^*(s) \triangleq \lim_{L \rightarrow \infty} \underline{R}_L^*(s) = \log_2 \left[\frac{(s-1)^{s-1}}{s^s} + 1 \right]. \quad (10)$$

The numerical values of the lower bound (6)-(8) are shown in Table 1, where the argument of maximum in (6) is denoted by $Q_L^*(s)$. Note that the lower bound (6)-(8) improves the random coding bound obtained in [14] using the

ensemble with independent binary symbols of codewords. In addition one can see that for small values of $s \geq 2$ and $L \geq 1$, the lower bounds (6)-(8) are greater than the lower bounds $\underline{R}_L(s)$ on the rate of LD s_L -codes from [12].

Note that, for $s \rightarrow \infty$, the asymptotic lower bound of $\underline{R}_L^*(s)$ (9) coincides with the asymptotic behavior of the random coding bound on the rate of LD s_L -codes [12]. In addition, for $L \rightarrow \infty$, the asymptotics of $\underline{R}_L^*(s)$ (10) coincides with the asymptotic behavior of the mentioned above bound from [12].

Table 1. Numerical values of the lower bound $\underline{R}_L^*(s)$

s_L	2 ₁	2 ₂	2 ₃	2 ₄	2 ₅	2 ₆
$\underline{R}_L^*(s)$	0.2075	0.2457	0.2635	0.2744	0.2819	0.2874
$\underline{Q}_L^*(s)$	0.5000	0.2764	0.2432	0.2297	0.2228	0.2180
s_L	3 ₁	3 ₂	3 ₃	3 ₄	3 ₅	3 ₆
$\underline{R}_L^*(s)$	0.0800	0.1153	0.1348	0.1470	0.1552	0.1611
$\underline{Q}_L^*(s)$	0.2000	0.1794	0.1686	0.1613	0.1561	0.1524
s_L	4 ₁	4 ₂	4 ₃	4 ₄	4 ₅	4 ₆
$\underline{R}_L^*(s)$	0.0439	0.0684	0.0838	0.0941	0.1014	0.1068
$\underline{Q}_L^*(s)$	0.1479	0.1391	0.1326	0.1275	0.1234	0.1201
s_L	5 ₁	5 ₂	5 ₃	5 ₄	5 ₅	5 ₆
$\underline{R}_L^*(s)$	0.0279	0.0456	0.0575	0.0660	0.0723	0.0771
$\underline{Q}_L^*(s)$	0.1209	0.1150	0.1103	0.1064	0.1030	0.1003
s_L	6 ₁	6 ₂	6 ₃	6 ₄	6 ₅	6 ₆
$\underline{R}_L^*(s)$	0.0194	0.0325	0.0420	0.0490	0.0544	0.0587
$\underline{Q}_L^*(s)$	0.1027	0.0983	0.0947	0.0915	0.0889	0.0865

2 Proof of Theorem 3

This Section contains five lemmas that are only stated. The proofs of Lemma 1-5 are presented in the preprint [16].

Proof of Statement 1. Fix $L \geq 1$, $s \geq 2$ and a parameter Q , $0 < Q \leq 1/2$. The bound (6)-(8) is obtained by the method of random coding over the ensemble of binary constant-weight codes [15] defined as the ensemble $E(N, t, Q)$ of binary codes X of length N and size t , where the codewords are chosen independently and equiprobably from the set consisting of all $\binom{N}{\lfloor QN \rfloor}$ codewords of a fixed weight $\lfloor QN \rfloor$. A pair of sets $(\mathcal{S}, \mathcal{L})$, $|\mathcal{S}| = s$, $|\mathcal{L}| = L$, $\mathcal{S} \cap \mathcal{L} = \emptyset$, we call an (s_L^*) -bad pair if

$$\bigvee_{i \in \mathcal{S}} \mathbf{x}(i) \supseteq \bigvee_{j \in \mathcal{L}} \mathbf{x}(j).$$

For the ensemble $E(N, t, Q)$, denote by $P(N, Q, s, L)$ the probability of the event “the pair $(\mathcal{S}, \mathcal{L})$ is (s_L^*) -bad”. Note that the absence of (s_L^*) -bad pair of subsets in the code is the criterion of SLD s_L -code. Hence, similarly to the arguments

in the proof of the lower random coding bound on the rate $R_L(s)$ (1) in [12], the rate $\underline{R}_L^*(s)$ (2) satisfies the inequality

$$\begin{aligned} R_L^*(s) &\geq \underline{R}_L^*(s) \triangleq \frac{1}{s+L-1} \max_{0 < Q < 1} A_L^*(s, Q), \\ A_L^*(s, Q) &\triangleq \overline{\lim}_{N \rightarrow \infty} \frac{-\log_2 P(N, Q, s, L)}{N}. \end{aligned} \quad (11)$$

Note that the set of all s_L^* -bad pairs of any codeword weight is invariant under the binary negation operation, it implies the equality $P(N, Q, s, L) = P(N, 1-Q, s, L)$. Therefore, it is enough to consider only $0 < Q \leq 1/2$.

To complete the proof of the theorem, it is sufficient to compute the function $A_L^*(s, Q)$ (11).

Lemma 1. [16] *If there exists a solution $z, 0 < z < 1$, of the equation (8), then the function $A_L^*(s, Q)$ (11) equals*

$$(s+L-1)h(Q) + (1-Q) \log_2 \left[\frac{p(z)}{p(z)+q(z)} \right] + Q \log_2 \left[\frac{p(1-z)}{p(1-z)+q(1-z)} \right], \quad (12)$$

where the functions $h(\cdot)$, $p(\cdot)$ and $q(\cdot)$ are determined by (7).

Lemma 2. [16] *The function*

$$\rho(z) \triangleq \frac{p(z)+q(z)}{p(1-z)+q(1-z)}, \quad 0 < z < 1,$$

continuously maps the interval $(0, 1)$ into $(0, +\infty)$ and strictly increases.

By Lemma 2 the equation (8) has the unique solution. Thus, the condition of Lemma 1 is clear, it means that the bound (6)-(8) is proved. \square

Proof of Statement 2. For fixed $s \geq 2$ and $L \geq 1$, let us interpret equation (8) as a function $Q_L(s, z)$ of the argument $z, 0 < z < 1$, i.e.,

$$Q_L(s, z) \triangleq \frac{p(1-z)+q(1-z)}{p(1-z)+q(1-z)+p(z)+q(z)}, \quad (13)$$

where the functions $p(\cdot)$ and $q(\cdot)$ are determined in (7).

Due to existence and uniqueness of the root of the equation (8), continuity and monotonicity of the function (13) (by Lemma 2), one can rewrite the definition of the random coding bound (6)-(8) as

$$\underline{R}_L^*(s) \triangleq \max_{1/2 \leq z < 1} T_L(s, z), \quad (14)$$

where

$$T_L(s, z) \triangleq h(Q_L(s, z)) + B_L(s, Q_L(s, z)). \quad (15)$$

Let $L \geq 1$ be fixed and $s \rightarrow \infty$. If in definition (15) we put $z = 1 - \lambda/s$, where the parameter $\lambda = \lambda_L$ is independent of s , then (14) means that

$$\underline{R}_L^*(s) \geq T_L \left(s, 1 - \frac{\lambda}{s} \right). \quad (16)$$

Lemma 3. [16] *For a fixed $L \geq 1$ and $s \rightarrow \infty$, the next asymptotic equality holds:*

$$T_L \left(s, 1 - \frac{\lambda}{s} \right) = \frac{L}{s^2} (-\lambda \log_2[1 - e^{-\lambda}]) (1 + o(1)). \quad (17)$$

Taking derivative one can check that at $\lambda = \frac{1}{\log_2 e}$ the maximum

$$\max_{\lambda > 0} \{-\lambda \log_2[1 - e^{-\lambda}]\} = \frac{1}{\log_2 e} \quad (18)$$

is attained. Therefore, (16) and (18) imply for the random coding bound (6)-(8) the asymptotic inequality (9). \square

Proof of Statement 3. For fixed $s \geq 2$ and $L \geq 1$, let us introduce the following function

$$g(z) \triangleq g_L(s, z) = \frac{z - z^s}{1 - z - (1 - z)^s}, \quad \frac{1}{2} \leq z < 1. \quad (19)$$

It is clear that $g(z)$ (19) monotonically increases in the interval $[1/2, 1)$, attains 1 at the point $z = \frac{1}{2}$ and has the left limit $s - 1$ as $z \rightarrow 1$.

For large enough parameter L and a fixed parameter $c > 0$ independent of L , one can see that the root of equation

$$\left(\frac{g(z)}{1 + g(z)} \right)^L = c(1 - z), \quad \frac{1}{2} \leq z < 1, \quad (20)$$

exists and is unique, since the left-hand side of (20) monotonically increases and the right-hand side of (20) strictly decreases. Denote this root by $z_L(s, c)$.

Let $s \geq 2$ be fixed and $L \rightarrow \infty$.

Lemma 4. [16] *The substitution of $z = z_L(s, c)$ into the function (15) yields*

$$\begin{aligned} T_L(s, z_L(s, c)) \cdot (1 + o(1)) &= \log_2[s + c] - \frac{s + c - 1}{s + c} \log_2[s + c - 1] + \\ &+ \frac{1}{s + c} \log_2 \left[\frac{(s - 1)^{s-1}}{s^s} \right], \quad L \rightarrow \infty. \end{aligned} \quad (21)$$

The definition (14) means that

$$\underline{R}_L^*(s) \geq T_L(s, z_L(s, c))(1 + o(1)), \quad L \rightarrow \infty, \quad \forall c = c(s) > 0. \quad (22)$$

Calculating the derivative in c , one can check that maximum of the right-hand side of (21) is attained at the point $c = c(s) = \frac{s^s - (s-1)^s}{(s-1)^{s-1}}$. If we substitute this value $c = c(s)$ into (21), then the use of (22) establishes for the random coding bound (6)-(8) the inequality

$$\underline{R}_L^*(s) \geq \log_2 \left[\frac{(s - 1)^{s-1}}{s^s} + 1 \right] (1 + o(1)), \quad L \rightarrow \infty. \quad (23)$$

Lemma 5. [16] *The asymptotic inequality (23) is an equality. Statement 3 of Theorem 3 is proved. \square*

References

1. Sobel M., Kumar S., Blumenthal S., Symmetric Binomial Group-Testing with Three Outcomes, *Purdue Symposium on Statistical Decision Theory and Related Topics*, 1971.
2. D'yachkov A.G., Rykov V.V., A Survey of Superimposed Code Theory, *Problems of Control and Inform. Theory*, vol. 12, no. 4, pp. 229-242, 1983.
3. Kautz W.H., Singleton R.C., Nonrandom Binary Superimposed Codes, *IEEE Trans. Inform. Theory*, vol. 10, no. 4, pp. 363-377, 1964.
4. D'yachkov A.G., Rykov V.V., An Application of Codes for the Multiple Access Channel in the ALOHA Communication System, *Proceedings of the 6-th All-Union Seminar in Computing Networks, Moscow-Vinnitsa*, vol. 4, pp. 18-24, 1981 (in Russian).
5. D'yachkov A.G., Rykov V.V., Superimposed Codes for Multiple Accessing of the OR-channel, *1998 IEEE International Symposium on Information Theory, Boston, USA*, Aug. 1998.
6. D'yachkov A.G. Lectures on Designing Screening Experiments, *Lecture Note Series 10*, Combinatorial and Computational Mathematics Center, Pohang University of Science and Technology (POSTECH), Korea Republic, Feb. 2003 (survey, 112 pages).
7. Friedman A.D., Graham R.L., Ullman J.D., Universal single transition time asynchronous state assignments, *IEEE Trans. Comput.*, vol. 18, no. 6, pp. 541-547, 1969.
8. Cohen G.D., Schaathun H.G., Asymptotic overview on separating codes, *Tech. Report 248*, Department of Informatics, University of Bergen, Bergen, Norway, 2003.
9. Vilenkin P.A., On Constructions of List-Decoding Superimposed Codes, *Proc. 6th Int. Workshop on Algebraic and Combinatorial Coding Theory (ACCT-6), Pskov, Russia*, pp. 228-231, 1998.
10. Sholomov L.A., Binary Representation of Underdetermined Data, *Doklady Akademii Nauk*, vol. 448, no. 3, pp. 275-278, 2013.
11. Sholomov L.A., Binary Representations of Underdetermined Data and Superimposed Codes, *Prikl. Diskr. Mat.*, no. 1, pp. 17-33, 2013 (in Russian).
12. D'yachkov A.G., Vorobyev I.V., Polyanskii N.A., Shchukin V.Yu., Bounds on the Rate of Disjunctive Codes, *Problems of Information Transmission*, vol. 50, no. 1, pp. 27-56, 2014.
13. D'yachkov A.G., Vorobyev I.V., Polyanskii N.A., Shchukin V.Yu., Bounds on the Rate of Superimposed Codes, *2014 IEEE International Symposium on Information Theory*, pp. 2341-2345, Honolulu, HI USA, Jun.29-Jul.4, 2014.
14. Ahmed M. Rashad, On Symmetrical Superimposed Codes, *J. Inf. Process. Cybern EIK 29*, vol. 7, pp. 337-341, 1989.
15. D'yachkov A.G., Rykov V.V., Rashad A.M., Superimposed Distance Codes, *Problems of Control and Inform. Theory*, vol. 18, no 4, pp. 237-250, 1989.
16. D'yachkov A.G., Vorobyev I.V., Polyanskii N.A., Shchukin V.Yu., Symmetric Disjunctive List-Decoding Codes, *arXiv:1410.8385 [cs.IT]*, 2014.