



HAL
open science

A moment matrix approach to computing symmetric cubatures

M Collowald, Evelyne Hubert

► **To cite this version:**

M Collowald, Evelyne Hubert. A moment matrix approach to computing symmetric cubatures. 2015.
hal-01188290v1

HAL Id: hal-01188290

<https://inria.hal.science/hal-01188290v1>

Preprint submitted on 28 Aug 2015 (v1), last revised 12 Nov 2015 (v2)

HAL is a multi-disciplinary open access archive for the deposit and dissemination of scientific research documents, whether they are published or not. The documents may come from teaching and research institutions in France or abroad, or from public or private research centers.

L'archive ouverte pluridisciplinaire **HAL**, est destinée au dépôt et à la diffusion de documents scientifiques de niveau recherche, publiés ou non, émanant des établissements d'enseignement et de recherche français ou étrangers, des laboratoires publics ou privés.

A moment matrix approach to computing symmetric cubatures

M. Collowald, E. Hubert

August 28, 2015

Abstract

A quadrature is an approximation of the definite integral of a function by a weighted sum of function values at specified points, or nodes, within the domain of integration. Gaussian quadratures are constructed to yield exact results for any polynomial of degree $2r - 1$ or less by a suitable choice of r nodes and weights. Cubature is a generalization of quadrature in higher dimension. Constructing a cubature amounts to find a linear form

$$\Lambda : \mathbb{R}[x] \rightarrow \mathbb{R}, p \mapsto \sum_{j=1}^r a_j p(\xi_j)$$

from the knowledge of its restriction to $\mathbb{R}[x]_{\leq d}$. The unknowns are the number of nodes r , the weights a_j and the nodes ξ_j .

An approach based on moment matrices was proposed in [25]. We give a basis-free version in terms of the Hankel operator \mathcal{H} associated to Λ . The existence of a cubature of degree d with r nodes boils down to conditions of ranks and positive semidefiniteness on \mathcal{H} . We then recognize the nodes as the solutions of a generalized eigenvalue problem.

Standard domains of integration are symmetric under the action of a finite group. It is natural to look for cubatures that respect this symmetry [13, 27, 28]. Introducing adapted bases obtained from representation theory, the symmetry constraint allows to block diagonalize the Hankel operator \mathcal{H} . We then deal with smaller-sized matrices both for securing the existence of the cubature and computing the nodes. The sizes of the blocks are furthermore explicitly related to the orbit types of the nodes with the new concept of the matrix of multiplicities of a finite group. It provides preliminary criteria of existence of a cubature with a given organisation of the nodes in orbit types.

The Maple implementation of the presented algorithms allows to determine, with moderate computational efforts, all the symmetric cubatures of a given degree. We present new relevant cubatures.

Contents

1	Introduction	4
2	Cubatures	6
2.1	Gaussian quadratures	6
2.2	Cubatures and minimal number of nodes	10
2.3	Construction of cubatures and lower bounds on the number of nodes	11
2.4	A moment matrix approach to cubatures	15
2.5	Contributions	17
2.6	Related problems	18
3	Hankel operators and flat extension of moment matrices	21
3.1	Zero-dimensional ideals	21
3.2	Hankel operators of finite rank	24
3.3	Kernels of Hankel operators and radical ideals	29
3.4	Flat extension	30
4	Fraction-free diagonalization of positive semidefnite matrices	33
4.1	Positive semidefnite matrices	34
4.2	Fraction-free triangularization and diagonalization	36
4.3	Diagonalization over the locus positivity	39
4.4	Diagonalization for determining the existence of cubatures	41
5	Moment matrix approach to computing cubatures	43
5.1	Existence conditions for a cubature	43
5.2	Existence of an inside cubature	45
5.3	Computation of the weights and the coordinates of the nodes	46
5.4	H_2 5 – 1 (Stroud, 1971): a first resolution	47
6	Symmetry adapted bases	50
6.1	Linear representations and characters	50

6.2	Unitary symmetry adapted bases	52
6.3	Invariant Hermitian forms	54
6.4	Orthogonal symmetry adapted bases	56
6.5	Invariant symmetric bilinear forms	60
7	Matrix of multiplicities	63
7.1	Permutation representations	63
7.2	Orbits and isotropy subgroups	64
7.3	The cyclic group C_m with $m \geq 2$	65
7.4	The dihedral group D_m with $m \geq 2$	67
7.4.1	Case m odd	69
7.4.2	Case m even	71
8	Hankel operators and symmetry	76
8.1	Block diagonalization	76
8.2	Block size	79
9	Algorithm for computing symmetric cubatures	83
9.1	Initialization and subroutines	84
9.2	Existence conditions for a G -invariant cubature	88
9.3	Computation of the weights and the coordinates of the nodes	90
9.4	H_2 5 - 1 (Stroud, 1971)	93
10	D_6-invariant cubatures of degree 13 for the regular hexagon	97
10.1	Existence of cubatures with at least 37 nodes	97
10.2	Computation of the weights and the nodes of the 4 cubatures	100

1 Introduction

Interpolatory quadratures offer a mean to approximate the integral of a function on an interval by the weighted sum of evaluations at a finite set of *nodes* in the interval. A criterion for the quality of the approximation is the degree of the polynomials for which the so obtained value is the exact value of the integral. Gaussian quadratures achieve a degree $2r - 1$ using only r well-chosen nodes. The nodes are known to be the roots of the orthogonal polynomials associated with the integral operator considered. Integration in higher dimension does not enjoy as clear-cut an answer. Relevant integration schemes are still being investigated for the standard domains like the simplex and the square. Those are necessary for the discretization of partial differential equations, whether in high degree for isogeometric analysis [44, 59] or in high dimensions [11, 57]. A simple product of Gaussian quadratures is *curse*d by dimensionality. Our original motivation resides in the use of integration in the geometric modeling of shapes based on a skeleton [42, 43, 82, 83].

The present paper offers a methodology to determine cubatures, that is compute its nodes and weights, in an intrinsically multivariate way. Started by Radon [70] the subject has been overviewed in [13, 14, 78]. We take on the moment matrix approach already described in [25]. The emergence of moment methods in polynomial optimization [49, 56] and their application to computational algebraic geometry [52] have brought out effective techniques to compute cubatures in floating point arithmetic [1]. Our contribution bears on the use of symmetry to reduce the size of the matrices involved and the number of parameters. We can determine, in exact arithmetic, the existence of high degree cubatures and set up the generalized eigenvalue problems the solutions of which are the nodes of the cubature.

Symmetry occurs naturally in the search for quality cubatures. The standard domains of integration (simplex, parallelepiped, sphere) can be normalized to their unit, and highly symmetric, counterpart by an affine transformation. The degree of the cubature is unchanged by such a transformation. The symmetric cubatures we compute furthermore retain the invariance properties of the integral operator being approximated. The key to bring out the structure implied by the symmetry is to stir away from the usual monomial bases of polynomial vector spaces. Building on the ideas in [16, 29, 72], we introduce the *orthogonal symmetry adapted bases*. They allow to block diagonalize the matrix of the Hankel operator, a.k.a. the moment matrix. Further diagonalization of the blocks would provide a basis of (multivariate) orthogonal polynomials.

The rank of the Hankel operator that is central in our approach is equal to the number of nodes of the cubature. In the presence of symmetry we can make further analyses: the ranks of the diagonal blocks are related to the organization of the nodes in orbit types. The relation is made explicit thanks to the new concept of the *matrix of multiplicities* associated with the group of symmetry. Beside introducing the notion we provide the matrices of multiplicities for the cyclic and dihedral groups. This allows to ascertain that the relation between the ranks and the organization of the nodes in orbit types is one-to-one. Importantly, this concept provides us with preliminary criteria to dismiss certain organizations of nodes in orbit types to build a cubature on.

An additional contribution in the paper is the fraction-free and pivoting free diagonalization of symmetric matrices over their locus of positivity. This is the exact arithmetic algorithm we use to discuss all the symmetric cubatures of a given degree.

The algorithms described in the paper are implemented in Maple. They have been applied to

recover a number of known cubatures. New cubatures have arisen from the possibility offered in our approach to investigate, with moderate computational efforts, all the symmetric cubatures of a given degree.

The paper is organized as follows. Section 2 is of an introductory nature, reviewing the subject of cubatures, and providing an overview of the techniques developed in this paper. Section 3 reviews Hankel operators and their properties. Section 4 describes the fraction and pivoting free algorithm to diagonalize symmetric matrices on their locus of positivity. Section 5 makes precise how the tools exposed so far apply to compute cubatures with a moment matrix approach. The sections afterwards all concern the symmetric case. Section 6 details the construction of orthogonal symmetric bases while Section 7 introduces orbit types and the matrix of multiplicities. This latter section also provides the matrices of multiplicities for the cyclic and dihedral groups. Section 8 details the block diagonal structure of the Hankel operator in the presence of symmetry. In particular we relate the size of the blocks to the organization of the nodes in orbit types. Section 9 provides the detail of the algorithmic content of our approach. The description there introduces how the code has been organized and is used. The following sections offer relevant cubatures for which our approach gave new insight.

2 Cubatures

Finding quadratures is a classical problem. The minimal number of nodes to maximize its degree and the construction of Gaussian quadratures thanks to univariate orthogonal polynomials are well-established (see *e.g.* [77, 78] and references herein). The same issues for its multivariate analogues, called *cubatures*, are still open problems in the general case.

To introduce the moment matrix approach, we first present a one-dimensional version of it. We recall then some results on cubatures based on reviews on the subject [13, 14, 78]: existence of cubatures and bounds on the minimal number of nodes (Tchakaloff's and Mysovnikh's theorems), classical approaches that use either product of Gaussian quadratures, or the theory of multivariate orthogonal polynomials. The symmetry of the involved measure appears as a natural ally in order to reduce the complexity of these approaches. We present then a recent approach based on moment matrices [25] and describe our main contribution: how symmetry is taken advantage of in the moment matrix approach to cubatures.

In the following, \mathbb{K} denotes a field of characteristic zero: the complex numbers \mathbb{C} , the real numbers \mathbb{R} or the rational numbers \mathbb{Q} . $\mathbb{K}[x]$ denotes the ring of polynomials in the variables $x = (x_1, \dots, x_n)$ with coefficients in \mathbb{K} , $\mathbb{K}[x]_{\leq \delta}$ the \mathbb{K} -vector space of polynomials of degree at most δ and $\mathbb{K}[x]_{\delta}$ the \mathbb{K} -vector space that contains all homogeneous polynomials of degree exactly δ and the zero polynomial. For $k = (k_1, \dots, k_n) \in \mathbb{N}^n$, x^k denotes the monomial $x_1^{k_1} \dots x_n^{k_n}$.

2.1 Gaussian quadratures

In this section, the classical quadrature problem is introduced (see *e.g.* [77, Chapter 3] or [78, Chapter 1.3] and references herein) and methods to determine Gaussian quadratures are presented. While a classical approach uses the theory of orthogonal polynomials (see *e.g.* [20, Chapter 1]), we give here an alternative approach, the one that we extend to the multidimensional case in the next sections. Here, $\mathbb{R}[x]$ denotes the \mathbb{R} -vector space of all polynomials with one variable and coefficients in \mathbb{R} .

Consider the linear form Ω on $\mathbb{R}[x]$ defined by

$$\Omega : \mathbb{R}[x] \rightarrow \mathbb{R}, p \mapsto \int_a^b p(x)\omega(x)dx,$$

where $[a, b] \subset \mathbb{R}$ is an interval (finite or infinite) and ω is a nonnegative *weight function* defined on this interval, that is a function that satisfies the following requirements:

- ω is measurable on the interval $[a, b]$ and $\omega(x) \geq 0$ for all $x \in [a, b]$.
- The *moments* $m_k = \int_a^b x^k \omega(x) dx$ exist and are finite for all $k \in \mathbb{N}$.
- For any polynomial $p \in \mathbb{R}[x]$ that is nonnegative on $[a, b]$,

$$\int_a^b p(x)\omega(x)dx = 0 \quad \Rightarrow \quad p(x) = 0.$$

A measure μ is associated with Ω . It is defined by

$$d\mu = \mathbb{1}_{[a,b]}\omega(x)dx,$$

where $\mathbb{1}_{[a,b]}$ is the characteristic function of the interval $[a, b]$

$$\mathbb{1}_{[a,b]} : \mathbb{R} \rightarrow \{0, 1\}, x \mapsto \begin{cases} 1 & \text{if } x \in [a, b] \\ 0 & \text{otherwise} \end{cases}.$$

A linear form Λ on $\mathbb{R}[x]$ defined by

$$\Lambda : \mathbb{R}[x] \rightarrow \mathbb{R}, p \mapsto \sum_{j=1}^r a_j p(\xi_j),$$

with $r > 0$, $a_j \in \mathbb{R} \setminus \{0\}$ and $\xi_j \in \mathbb{R}$ pairwise distinct, is called a *quadrature of degree d* for the measure μ if it satisfies

$$\int_a^b p(x)\omega(x)dx = \sum_{j=1}^r a_j p(\xi_j) \quad \forall p \in \mathbb{R}[x]_{\leq d}$$

and if this equality does not hold for at least one polynomial p of degree $d + 1$. The points ξ_j are the *nodes* and the coefficients a_j are the *weights* of the quadrature. Such a quadrature is called *inside* if the nodes ξ_j lie on the interval $[a, b]$ and *minimal* if the number of nodes r is minimal for a fixed degree d .

In this univariate case, minimal inside quadratures with positive weights are known and called *Gaussian quadratures* (see e.g. [77, Chapter 3.6] for more details). A Gaussian quadrature with r nodes is of degree $2r - 1$.

Several methods are known for the determination of the nodes of a quadrature. Its weights are generally obtained afterwards by solving the Vandermonde linear system

$$\begin{pmatrix} 1 & 1 & \dots & 1 \\ \xi_1 & \xi_2 & \dots & \xi_r \\ \vdots & \vdots & & \vdots \\ \xi_1^{r-1} & \xi_2^{r-1} & \dots & \xi_r^{r-1} \end{pmatrix} \begin{pmatrix} a_1 \\ a_2 \\ \vdots \\ a_{r-1} \end{pmatrix} = \begin{pmatrix} m_0 \\ m_1 \\ \vdots \\ m_{r-1} \end{pmatrix} \quad (2.1)$$

obtained from the equations

$$m_k = \Lambda(x^k) = \sum_{j=1}^r a_j \xi_j^k \quad \forall k = 0, \dots, r - 1. \quad (2.2)$$

Moment matrix approach for the computation of the nodes of a Gaussian quadrature

Assume that a Gaussian quadrature of degree $2r - 1$ exists for μ , that is there exists a linear form

$$\Lambda : \mathbb{R}[x] \rightarrow \mathbb{R}, p \mapsto \sum_{j=1}^r a_j p(\xi_j)$$

with $a_j > 0$ and $\xi_j \in [a, b]$ pairwise distinct such that $m_k = \Lambda(x^k)$ for all $k \leq 2r - 1$.

Consider the monic polynomial π_r of degree r whose roots are the nodes ξ_1, \dots, ξ_r

$$\pi_r(x) = \prod_{j=1}^r (x - \xi_j) = x^r - \tau_{r-1}x^{r-1} - \dots - \tau_0.$$

Since $\pi_r(\xi_j) = 0$ for all $j = 1, \dots, r$, we have $\Lambda(\pi_r) = 0$ and even

$$\Lambda(p\pi_r) = 0 \quad \forall p \in \mathbb{R}[x]. \quad (2.3)$$

Taking $p(x) = x^k$ for $k = 0, \dots, r$, we deduce by linearity of Λ that

$$\sum_{i=0}^{r-1} \tau_i \Lambda(x^{k+i}) - \Lambda(x^{k+r}) = 0 \quad \forall k = 0, \dots, r.$$

Thus, the vector $(\tau_0 \ \dots \ \tau_{r-1} \ -1)^t$ is in the kernel of the Hankel matrix

$$H_1^{B^{(r)}} = (\Lambda(x^{i+j-2}))_{1 \leq i, j \leq r+1} = \begin{pmatrix} \Lambda(1) & \Lambda(x) & \dots & \Lambda(x^r) \\ \Lambda(x) & & \ddots & \vdots \\ \vdots & \ddots & & \vdots \\ \Lambda(x^r) & \dots & \dots & \Lambda(x^{2r}) \end{pmatrix}.$$

The latter is the matrix of the symmetric bilinear form

$$\varphi : \mathbb{R}[x] \times \mathbb{R}[x] \rightarrow \mathbb{R}, (p, q) \mapsto \Lambda(pq)$$

restricted to $\mathbb{R}[x]_{\leq r}$ in the monomial basis $B^{(r)} = \{1, x, \dots, x^r\}$.

Alternatively, we observe that

$$H_1^{B^{(r-1)}} M_x^{B^{(r-1)}} = H_x^{B^{(r-1)}} \quad (2.4)$$

with $H_1^{B^{(r-1)}} = (\Lambda(x^{i+j-2}))_{1 \leq i, j \leq r}$, $H_x^{B^{(r-1)}} = (\Lambda(x^{i+j-1}))_{1 \leq i, j \leq r}$ and where $M_x^{B^{(r-1)}}$ is the companion matrix of the polynomial π_r

$$M_x^{B^{r-1}} = \begin{pmatrix} 0 & \dots & \dots & 0 & \tau_0 \\ 1 & \ddots & & \vdots & \tau_1 \\ 0 & \ddots & \ddots & \vdots & \vdots \\ \vdots & \ddots & \ddots & 0 & \vdots \\ 0 & \dots & 0 & 1 & \tau_{r-1} \end{pmatrix}.$$

Since the eigenvalues of the companion matrix $M_x^{B^{(r-1)}}$ are the roots of the polynomial π_r , the generalized eigenvalues of the pair of Hankel matrices $(H_x^{B^{(r-1)}}, H_1^{B^{(r-1)}})$ are the sought nodes ξ_1, \dots, ξ_r .

The entries of those Hankel matrices are known since Λ is a cubature of degree $2r - 1$. Indeed, $H_1^{B^{(r-1)}}$ (resp. $H_x^{B^{(r-1)}}$) corresponds to the matrix $(m_{i+j-2})_{1 \leq i, j \leq r}$ (resp. $(m_{i+j-1})_{1 \leq i, j \leq r}$) of the symmetric bilinear form

$$\begin{aligned} \Phi : \mathbb{R}[x] \times \mathbb{R}[x] &\rightarrow \mathbb{R}, (p, q) \mapsto \int_a^b p(x)q(x)\omega(x)dx \\ (\text{resp. } \Phi_x : \mathbb{R}[x] \times \mathbb{R}[x] &\rightarrow \mathbb{R}, (p, q) \mapsto \int_a^b xp(x)q(x)\omega(x)dx \quad) \end{aligned}$$

restricted to $\mathbb{R}[x]_{\leq r-1}$ in the monomial basis $B^{(r-1)}$. The matrix $H_1^{B^{(r-1)}}$ is therefore called a *moment matrix*.

A classical approach using orthogonal polynomials

We remark here on the link between quadratures and orthogonal polynomials with respect to the symmetric bilinear form Φ . The latter defines actually an inner product on the \mathbb{R} -vector space $\mathbb{R}[x]$ and the polynomial π_r constructed above is the monic orthogonal polynomial of degree r . Indeed, since Λ is a cubature of degree $2r - 1$ and with the help of (2.3), we get

$$\Phi(p, \pi_r) = \Lambda(p\pi_r) = 0 \quad \forall p \in \mathbb{R}[x]_{\leq r-1}. \quad (2.5)$$

Moreover, since one can construct exactly one monic orthogonal polynomial π_r per degree, the polynomials π_r form a basis Π of $\mathbb{R}[x]$. The 'infinite' matrix of Φ in the basis Π is therefore a diagonal matrix, whose diagonal elements are $\Phi(\pi_r, \pi_r)$, and the 'infinite' matrix of Φ_x in the basis Π is tridiagonal since

$$\Phi_x(\pi_{r_1}, \pi_{r_2}) = \Phi(\pi_{r_1}, x\pi_{r_2}) = 0 \text{ if } r_2 \leq r_1 - 2,$$

$$\Phi_x(\pi_{r_1}, \pi_{r_2}) = \Phi(x\pi_{r_1}, \pi_{r_2}) = 0 \text{ if } r_1 \leq r_2 - 2.$$

Taking now the basis $\tilde{\Pi}$ defined by the orthonormal polynomials $\tilde{\pi}_r$, obtained by normalizing the monic orthogonal polynomials π_r , we have that:

- The 'infinite' matrix of Φ in the basis $\tilde{\Pi}$ is the identity.
- The 'infinite' tridiagonal matrix of Φ_x in the basis $\tilde{\Pi}$ is the *Jacobi matrix*

$$J = \begin{pmatrix} a_0 & b_0 & 0 & \dots \\ b_0 & a_1 & b_1 & \ddots \\ 0 & b_1 & \ddots & \ddots \\ \vdots & \ddots & \ddots & \ddots \end{pmatrix},$$

where $(a_r)_{r \in \mathbb{N}}$ and $(b_r)_{r \in \mathbb{N}}$ are sequences of real numbers that reflect the recurrence equation of order 2 satisfied by the orthonormal polynomials $\tilde{\pi}_r$ (see *e.g.* [20, Corollary 1.3.10],[2, Chapter 1]):

$$\begin{cases} x\tilde{\pi}_r(x) = b_r\tilde{\pi}_{r+1}(x) + a_r\tilde{\pi}_r(x) + b_{r-1}\tilde{\pi}_{r-1}(x) & \forall r \geq 1 \\ x\tilde{\pi}_0(x) = b_0\tilde{\pi}_1(x) + a_0\tilde{\pi}_0(x) \end{cases}.$$

- Applying a change of basis in (2.4), the eigenvalues of the $r \times r$ leading principal submatrix of the Jacobi matrix J are the roots of the orthonormal polynomial $\tilde{\pi}_r$, or equivalently the nodes ξ_1, \dots, ξ_r . See [77, Theorem 3.6.20] for the classical link between eigenvalues of tridiagonal matrices and roots of orthogonal polynomials.

2.2 Cubatures and minimal number of nodes

Cubatures are the multidimensional analogues of quadratures. However, as stated in [78, Chapter 1.3], there is a gap between the construction of minimal quadratures and the construction of minimal cubatures. In particular, the number of minimal nodes is only known in some cases. $\mathbb{R}[x]$ denotes now the \mathbb{R} -vector space of the polynomials with n variables and coefficients in \mathbb{R} with $n > 2$.

Let μ be a positive Borel measure on \mathbb{R}^n and let $\text{supp } \mu$ be the closed support of the measure μ , that is the complement of the biggest open set $\mathcal{U} \subset \mathbb{R}^n$ with $\mu(\mathcal{U}) = 0$. As in [67, Theorem 1], we assume that $\text{supp } \mu$ is compact. Given any $k \in \mathbb{N}^n$, the moment m_k

$$m_k = \int_{\mathbb{R}^n} x^k d\mu(x)$$

therefore exists and is finite. More generally, let Ω be the linear form defined from μ by

$$\Omega : \mathbb{R}[x] \rightarrow \mathbb{R}, p \mapsto \int_{\mathbb{R}^n} p(x) \omega(x) d\mu(x).$$

A linear form Λ defined on $\mathbb{R}[x]$ by

$$\Lambda : \mathbb{R}[x] \rightarrow \mathbb{R}, p \mapsto \sum_{j=1}^r a_j p(\xi_j)$$

with $r > 0$, $a_j \in \mathbb{R} \setminus \{0\}$ and $\xi_j \in \mathbb{R}^n$ pairwise distinct is called a *cubature of degree d* for μ if it satisfies

$$\int_{\mathbb{R}^n} p(x) d\mu(x) = \sum_{j=1}^r a_j p(\xi_j) \quad \forall p \in \mathbb{R}[x]_{\leq d} \quad (2.6)$$

and if this last equality does not hold for at least one polynomial $p \in \mathbb{R}[x]_{d+1}$. The points ξ_j are the *nodes* and the numbers a_j are the *weights* of the cubature. Such a cubature is called *inside* if the nodes ξ_j lie on $\text{supp } \mu$ and *minimal* if the number of nodes r is minimal.

In our examples, the measure μ is the characteristic function of a compact in \mathbb{R}^n : 1 on $\text{supp } \mu$ and 0 otherwise. Thus, we often abuse the definition and a cubature for the characteristic function of a compact K is simply called a cubature for K .

Given a positive Borel measure with compact support in \mathbb{R}^n , we are interested in finding inside cubatures with positive weights. Cubatures with these properties are generally numerically more stable than cubatures for which one or both of these properties is lacking [78, Chapter 1]. Their existence is guaranteed with an upper bound on the minimal number of nodes by Tchakaloff's theorem [67, Theorems 1,2],[7, Theorem 2]. Contrary to the one-dimensional case, minimal cubatures are generally not known. A lower bound is provided by [20, Theorem 3.7.1]. Combining those general results, we get

Theorem 2.1. *Let d be a positive integer and let μ be a positive Borel measure with compact support in \mathbb{R}^n . Then there exists an inside cubature of degree d with positive weights the number of nodes r of which satisfies*

$$\dim \mathbb{R}[x]_{\leq \lfloor \frac{d}{2} \rfloor} \leq r \leq \dim \mathbb{R}[x]_{\leq d}.$$

Notice that Tchakaloff's theorem was originally proved for compact regions in the plane \mathbb{R}^2 as reported in [78, Theorem 3.3-6]. The authors in [7, 67] proved more sophisticated versions of Tchakaloff's theorem with lighter hypotheses on the measure μ .

To conclude this section, we shortly discuss the differences between quadratures and cubatures and, as a consequence, the challenge to find minimal cubatures. In [78, Chapter 1.3], the author relates it to two main issues. The first one is a geometric issue, whereas the second one is related to the theory of orthogonal polynomials.

The geometric issue is related to the following property: compact sets being equivalent under an affine transformation have minimal cubatures with the same number of nodes [78, Theorem 1.4-1]. There is essentially one compact set in the one-dimensional case, whereas there are infinitely many distinct compact sets in the multidimensional case. For instance, cubatures for the triangle, the square or the disk are different from each other.

In the multidimensional case, the theory of orthogonal polynomials states that a lower bound on the number of nodes of a cubature of degree $d = 2k - 1$ is given by $\dim \mathbb{R}[x]_{\leq k-1}$ [20, Theorem 3.7.1]. As an analogy, a cubature that attains this bound is called a *Gaussian cubature*. However its existence is not guaranteed. Mysovskikh's theorem [20, Theorem 3.7.4] states that a Gaussian cubature of degree $2k - 1$ exists if and only if the set of orthogonal polynomials of degree k has exactly $\dim \mathbb{R}[x]_{\leq k-1}$ common zeros. In [50], the author provides an alternative criterion based on moment matrices for the existence of a Gaussian cubature, which reduces to checking whether a certain overdetermined linear system has a solution. Notice that, if a Gaussian cubature exists, the weights are positive [20, Corollary 3.7.5] and the nodes belong to the interior of the convex hull of $\text{supp } \mu$ [14, Theorem 7].

Gaussian cubatures are rare as stated in [58, 74], where the authors give an example of such a minimal cubature for every degree.

2.3 Construction of cubatures and lower bounds on the number of nodes

As presented in reviews on the topic [13, 78], cubatures have been constructed using several techniques like ones based on product of Gaussian quadratures, on solutions of multivariate nonlinear systems or on zeros of multivariate orthogonal polynomials. More recently, the authors in [25] based their construction on moment matrices. This last approach is the one we choose and a first presentation is given in Section 2.4.

Techniques based on product of Gaussian quadratures

The techniques based on product of Gaussian quadratures are called either *product formulas* [78, Chapter 2] or *repeated quadratures* [13, Section 4.1]. Consider the compact set $[a_1, b_1] \times \cdots \times [a_n, b_n]$ with $a_1, \dots, a_n, b_1, \dots, b_n \in \mathbb{R}$. For each interval $[a_i, b_i]$, a Gaussian quadrature Λ_i is chosen

$$\Lambda_i : \mathbb{R}[x] \rightarrow \mathbb{R}, p \mapsto \sum_{j_i=1}^{r_i} a_{j_i} p(\xi_{j_i}).$$

The Gaussian quadratures Λ_i may be the same or distinct ones (of distinct degrees d_i for instance). The whole cubature Λ for $[a_1, b_1] \times \cdots \times [a_n, b_n]$ is then

$$\Lambda : \mathbb{R}[x] \rightarrow \mathbb{R}, p \mapsto \sum_{j_1=1}^{r_1} \cdots \sum_{j_n=1}^{r_n} a_{j_1} \cdots a_{j_n} p(\xi_{j_1}, \dots, \xi_{j_n}). \quad (2.7)$$

The degree d of such a cubature is between $\min\{d_1, \dots, d_n\}$ and $\max\{d_1, \dots, d_n\}$.

Cubatures for other compact sets are then obtained from (2.7) by performing a suitable change of variables as mentioned in [13, Section 4.2].

The main advantage is that cubatures of every odd degree can be constructed. However, the required number of nodes is then larger than the one of known cubatures obtained in a different way. For instance, there are inside cubatures with positive weights of degree 9, 11, 13, 15 for the square with respectively 17, 24, 33, 44 nodes [15]; whereas cubatures based on product of Gaussian quadratures of the same degree have respectively 25, 36, 49, 64 nodes. Another advantage is that Gaussian quadratures are well-known so that those cubatures remain popular (see *e.g.* [60, 61]).

Nonlinear systems and simplification using symmetry

The second approach starts by noticing that equalities (2.6) are satisfied for all polynomials of $\mathbb{R}[x]_{\leq d}$ with d the degree of the cubature if and only if they are satisfied for all polynomials in any basis $B^{(d)} = \{b_1, \dots, b_{r_d}\}$ of $\mathbb{R}[x]_{\leq d}$. Thus, taking $p = b_i$ for all $i = 1, \dots, r_d$ in (2.6), we get the multivariate nonlinear system

$$\sum_{j=1}^r a_j b_i(\xi_j) = \int_{\mathbb{R}^n} b_i(x) d\mu(x) \quad \forall i = 1, \dots, r_d, \quad (2.8)$$

where we assume that the values of the right-hand side can be computed. This is the case for instance for moments of the characteristic function of polytopes [3, 76]. However, since the size of the polynomial system (2.8) increases with the degree d of the sought cubature and the number of variables n , a direct resolution is limited to low degrees and small dimensions.

In view of the shape of standard regions of cubatures (n -dimensional hypercube, simplex or ball), a natural simplification in the resolution of the nonlinear system (2.8) comes from transformations that leave those regions invariant: the *symmetries*.

To give an idea, consider cubatures for the square or the disk that respect the symmetry of the square [69, Tables 1,2]. They satisfy: if $\xi_j = (x_{1,j}, x_{2,j})$ is a node and a_j is the corresponding weight, then $(\pm x_{1,j}, \pm x_{2,j})$ and $(\pm x_{2,j}, \pm x_{1,j})$ are also nodes associated with the same weight a_j . The set of nodes is then generated by nodes of the form: $(0,0)$, $(a,0)$, (b,b) , (c,d) , where a, b, c, d are in \mathbb{R} . Thus, the nonlinear system (2.8) can be simplified as presented in [69]: some moments of order bigger than the degree of the cubature are zero and smaller subsystems are extracted.

More generally, in any dimension, cubatures for the hypercube or the ball that respect the symmetry of the hypercube are listed in [38, Tables 1,2]. In this case, they satisfy: if $\xi_j = (x_{1,j}, \dots, x_{n,j})$ is a node and a_j is the corresponding weight, then $(\pm x_{\sigma(1),j}, \dots, \pm x_{\sigma(n),j})$ are also nodes associated with the same weight a_j , where σ is a permutation of the symmetric group

on n elements. A similar argument as the one given above leads to similar simplifications in the nonlinear system (2.8) as presented in [38].

A more general approach consists in relating the symmetry to the action of a group G on \mathbb{R}^n . Cubatures that respect this symmetry are called G -invariant [13, 27] (a precise definition is given in 8.1). They satisfy the following properties:

- The set of nodes ξ_j is a union of orbits of this group action.
- The weights a_j associated with nodes on a same orbit are identical.
- The cubature is of degree d if it is exact for all G -invariant polynomials of degree at most d and if it is not exact for at least one polynomial of degree $d + 1$ [13, Corollary 5.1 (Sobolev's theorem)].

While the last requirement reduces the number of equations in (2.8), the two first points reduce the number of unknowns, as in [38, 69].

Tables 2 and 4 in [27] list G -invariant cubatures for the square and the triangle with several groups G : cyclic groups C_m or dihedral groups D_m (see Sections 7.3 and 7.4 for a presentation of these groups). D_6 -invariant cubatures for the regular hexagon have been found following this approach in [35].

Orthogonal polynomials and lower bounds

Radon's work [70] marked a starting point in the search for cubatures thanks to orthogonal polynomials. As stated in [14], the theory developed following this way tries to generalize Radon's approach for higher degrees and dimensions. However, if multivariate orthogonal polynomials provide some results, they do not answer all the questions as in the one-dimensional case.

As in our presentation of the quadrature problem, we start with the computation of the weights a_1, \dots, a_r once the nodes ξ_1, \dots, ξ_r are known. Let p_1, \dots, p_r be polynomials of degree less than or equal to the degree d of the cubature Λ . The following equations are then satisfied

$$\int p_i d\mu = \Lambda(p_i) = \sum_{j=1}^r a_j p_i(\xi_j) \quad \forall i = 1, \dots, r.$$

The latter generalizes (2.2) for which $(p_1, p_2, \dots, p_r) = (1, x, \dots, x^{r-1})$. A linear system like (2.1) is thus deduced

$$\begin{pmatrix} p_1(\xi_1) & p_1(\xi_2) & \cdots & p_1(\xi_r) \\ p_2(\xi_1) & p_2(\xi_2) & \cdots & p_2(\xi_r) \\ \vdots & \vdots & & \vdots \\ p_r(\xi_1) & p_r(\xi_2) & \cdots & p_r(\xi_r) \end{pmatrix} \begin{pmatrix} a_1 \\ a_2 \\ \vdots \\ a_r \end{pmatrix} = \begin{pmatrix} \Lambda(p_1) \\ \Lambda(p_2) \\ \vdots \\ \Lambda(p_r) \end{pmatrix}. \quad (2.9)$$

The latter is called *Vandermonde-like* since the involved matrix can be seen as a multivariate generalization of a Vandermonde matrix [64]. Choosing the polynomials p_1, \dots, p_r such that the matrix in this Vandermonde-like linear system is invertible guarantees that the weights a_1, \dots, a_r are determined uniquely.

Cubatures whose weights are obtained uniquely from the nodes are called *interpolatory*. We focus on these since a subset of the nodes of a non-interpolatory cubature can be used as the set of nodes of an interpolatory one [13, Section 6.1].

Similarly to Section 2.1, a symmetric bilinear form Φ on the polynomial space $\mathbb{R}[x]$

$$\Phi : \mathbb{R}[x] \times \mathbb{R}[x] \rightarrow \mathbb{R}, (p, q) \mapsto \int pq \, d\mu$$

is associated with the measure μ . It defines an inner product on $\mathbb{R}[x]$. There are thus orthogonal polynomials π_ϱ ($\varrho \in \mathbb{N}^n$) with respect to Φ that satisfy the multivariate analogue of (2.5)

$$\Phi(p, \pi_\varrho) = \Lambda(p\pi_\varrho) = 0 \quad \forall p \in \mathbb{R}[x]_{\leq |\varrho|-1}.$$

Notice that there exist $\dim \mathbb{R}[x]_\delta$ unique orthogonal polynomials of degree δ of the form $x^\varrho + q$ with $|\varrho| = \delta$ and $q \in \mathbb{R}[x]_{\leq \delta-1}$ (see (6.3) in [13]). We refer to [20] for explicit expressions of multivariate orthogonal polynomials with respect to different measures and also for theoretical results on multivariate orthogonal polynomials.

The particular case of Gaussian cubatures was already discussed in Section 2.2. Their nodes are characterized as the common zeros of all orthogonal polynomials of degree $\lfloor \frac{d}{2} \rfloor$, where d is the odd degree of the Gaussian cubature (Mysovskikh's theorem). A more general approach involving multivariate orthogonal polynomials (see [13, Section 6], [14, Section 6] and references therein) keeps the idea from algebraic geometry that a set of points in \mathbb{R}^n corresponds to the variety (set of common zeros) of an ideal generated by an appropriate basis. Methods for the computation of this basis have been developed (see [13, Section 9] and references herein). For instance, as in Radon's work, the common zeros of a selection of three orthogonal polynomials of the same degree have been identified with the nodes of cubatures in the plane in [36, 37]. Notice that symmetry can again simplify the computations [13, Section 9.2].

This theory provides also lower bounds on the minimal number of nodes for a cubature of a fixed degree d [13, Sections 7,8],[14, Section 5]. Sharp lower bounds are important because they are the starting point of the search for cubatures in several methods. We mention here only two general lower bounds that link directly d and the number of nodes r :

- The first one is the one in Theorem 2.1

$$r \geq \dim \mathbb{R}[x]_{\leq \lfloor \frac{d}{2} \rfloor}.$$

- The second one works for *centrally symmetric* measures, which means that $m_\alpha = 0$ whenever $|\alpha|$ is odd, or equivalently that the measure is invariant under the symmetry $x \mapsto -x$. When $n = 2$, this bound can be written as

$$r \geq \dim \mathbb{R}[x]_{\leq k} + \left\lfloor \frac{k+1}{2} \right\rfloor \quad \text{with } d = 2k + 1. \quad (2.10)$$

It is then known as Möller's lower bound [81]. For the general case, we refer to [13, Theorem 8.3],[14, Theorem 13].

There exist thus no Gaussian cubatures of odd degree for centrally symmetric measures when $n = 2$.

2.4 A moment matrix approach to cubatures

The approach to cubatures we have, devised in [25], incorporates the results overviewed in [55] and additional influences like [51]. The details are given in Sections 3 and 4. In particular we do not restrict ourselves to monomial bases. The presentation we make prepares for the use of symmetry, where our main contribution resides.

Main ingredients

The moment matrix approach to cubatures is based on two main ingredients: the characterization of cubatures in terms of positive semidefinite matrices with a prescribed rank (see Sections 3.2 and 3.3) and a flat extension theorem to reconstruct the expected linear form on $\mathbb{R}[x]$ when working on a restriction to a finite dimensional space (see Section 3.4). We introduce here these ingredients in terms of matrices.

The characterization, the first ingredient, starts with the association of a linear form Λ on $\mathbb{R}[x]$ with the symmetric bilinear form

$$\varphi : \mathbb{R}[x] \times \mathbb{R}[x] \rightarrow \mathbb{R}, (p, q) \mapsto \Lambda(pq),$$

or equivalently, with the Hankel operator $\widehat{\mathcal{H}} : \mathbb{R}[x] \rightarrow \mathbb{R}[x]^*$ given by $\widehat{\mathcal{H}}(p)(q) = \Lambda(pq)$ for all $p, q \in \mathbb{R}[x]$. Fix a basis $B = (b_k)_{k \in \mathbb{N}}$ of $\mathbb{R}[x]$ such that it is possible to extract a basis $B^{(\delta)}$ of $\mathbb{R}[x]_{\leq \delta}$ for every degree $\delta \in \mathbb{N}$. Let H_1^B be the 'infinite' matrix of the symmetric bilinear form φ in the basis B

$$H_1^B = (\Lambda(b_i b_j))_{(i,j) \in \mathbb{N}^2}.$$

When B is a monomial basis, the matrix H_1^B is referred to as a *moment matrix*. The linear form Λ is then given by

$$\Lambda = \sum_{j=1}^r a_j \mathbb{1}_{\xi_j},$$

with $r > 0$, $a_j > 0$ and $\xi_j \in \mathbb{R}^n$ pairwise distinct, if and only if the 'infinite' matrix H_1^B has finite rank r and is positive semidefinite. The set of nodes $\{\xi_1, \dots, \xi_r\}$ is then the variety of the ideal I_Λ : the kernel of the Hankel operator $\widehat{\mathcal{H}}$.

This variety can be recovered by considering submatrices $H_1^{B^{(\delta)}}$ of H_1^B . They are the matrices of the restriction of φ to $\mathbb{R}[x]_{\leq \delta}$ in a basis $B^{(\delta)}$. Take the matrix $H_1^{B^{(\delta)}}$ such that its submatrix $H_1^{B^{(\delta-1)}}$ has the same rank r as the whole matrix. The variety of the kernel of $H_1^{B^{(\delta)}}$, which is a zero-dimensional and radical ideal, is then the set of nodes.

The flat extension theorem, the second ingredient, determines in finite terms when the matrix H_1^B has finite rank. Assume that a linear form $\Lambda^{(\delta)}$ is known on $\mathbb{R}[x]_{\leq 2\delta}$ and that the matrix $H_1^{B^{(\delta)}}$ associated with the bilinear form on $\mathbb{R}[x]_{\leq \delta}$ has the same rank as the matrix $H_1^{B^{(\delta-1)}}$ of its restriction to $\mathbb{R}[x]_{\leq \delta-1}$. Then there is a unique linear form Λ on the whole polynomial space $\mathbb{R}[x]$ such that

$$\Lambda(p) = \Lambda^{(\delta)}(p) \quad \forall p \in \mathbb{R}[x]_{\leq 2\delta} \text{ and } \text{rank } H_1^B = r.$$

Methodology

With the help of the two main ingredients presented above, a first procedure is proposed in Section 5 to determine the existence for the measure μ of a cubature Λ of a given degree d . We give here a short description of it:

- Choose a degree $\delta \in \mathbb{N}$ such that $\lfloor \frac{d}{2} \rfloor \leq \delta - 1 \leq d$.
- Take a monomial basis $B^{(\delta)} = \{b_1, \dots, b_{r_\delta}\}$ of $\mathbb{R}[x]_{\leq \delta}$.
- Construct the moment matrix $H_1^{B^{(\delta)}} = (\Lambda(b_i b_j))_{1 \leq i, j \leq r_\delta}$ whose entries are:
 - either moments $\int b_i b_j d\mu$ of the measure μ if $\deg(b_i b_j) \leq d$,
 - or parameters $h_{r_\delta+1}, \dots, h_{r_{2\delta}}$ that stand for the unknown quantities $\Lambda(b_{r_\delta+1}), \dots, \Lambda(b_{r_{2\delta}})$.
- Based on the two main ingredients presented above, determine values for $h_{r_\delta+1}, \dots, h_{r_{2\delta}}$ such that $H_1^{B^{(\delta)}}$ and $H_1^{B^{(\delta-1)}}$ are positive semidefinite of rank r (as small as possible).
- Determine the nodes ξ_1, \dots, ξ_r of the cubature by solving:
 - either the polynomial system given by the kernel of $H_1^{B^{(\delta)}}$: it corresponds to the ideal generated by orthogonal polynomials in Section 2.3;
 - or generalized eigenvalue problems of pairs (H_p^r, H_1^r) for $p \in \mathbb{R}[x]_{\leq 1}$ that *separates* the nodes, that is such that $p(\xi_1), \dots, p(\xi_r)$ are pairwise distinct. The matrix H_1^r is an invertible $r \times r$ submatrix of $H_1^{B^{(\delta-1)}}$, which is rewritten as $(\Lambda(\bar{b}_i \bar{b}_j))_{1 \leq i, j \leq r}$ with $\{\bar{b}_1, \dots, \bar{b}_r\} \subset B^{(\delta-1)}$. The matrix H_p^r is then the matrix $(\Lambda(p \bar{b}_i \bar{b}_j))_{1 \leq i, j \leq r}$.
- Determine the weights a_1, \dots, a_r of the cubature by solving the Vandermonde-like linear system (2.9) with $\{p_1, \dots, p_r\} = \{\bar{b}_1, \dots, \bar{b}_r\}$.

This procedure can be split in two main parts:

1. The first four points determine the existence for μ of a cubature Λ of degree d with positive weights.
2. The last two points compute the weights and the nodes once the existence is secured.

Theorem 2.1 guarantees the existence of a degree δ as in the first point of the procedure, and then values for the unknowns $h_{r_\delta+1}, \dots, h_{r_{2\delta}}$. Their determination is a problem of *low rank completion of structured matrices* of the same kind as the one that appears in tensor decomposition [10]. To deal with it, we propose an algorithm based on fraction-free LU-decompositions (see Section 4). This algorithm is applicable to matrices of small size, as the ones we shall obtain when symmetry is taken into account. When the size of the matrices increases, a new exact algorithm has been proposed in [40] to find at least a solution to this issue. They also refer to numerical SemiDefinite Programming solvers for higher dimensions.

There is an optional step between the two main parts, which consists in creating *localizing matrices* and verifying their positive semidefiniteness. It guarantees that the nodes lie on $\text{supp } \mu$ before their computation.

2.5 Contributions

The methodology described above is based on a synthesis of results on moment matrices and truncated moment problems [18, 25, 54, 55]. Our motivation was to tie in symmetry. Related symmetric problems are treated in [16, 29, 72].

Symmetry appears as a natural property to preserve. Many cubatures for standard regions in the plane \mathbb{R}^2 (triangle, square, hexagon, disk) or in the space \mathbb{R}^n (simplex, hypercube, ball) were computed by imposing a symmetry of the measure to the cubature: in the nonlinear system [27, 35, 38, 69] or in the orthogonal polynomials [36, 37]. As a consequence, constraints are added to the unknowns used in those techniques. The determination of cubatures is thus simplified. This is also the case in the moment matrix approach:

- The matrix $H_1^{B^{(\delta)}}$ we shall deal with has less parameters h_ℓ than in the procedure presented above (Step 6 in Algorithm 9.6 [Existence of a G -invariant cubature]).
- This matrix is also block diagonal, when the basis $B^{(\delta)}$ is well-chosen. Thus, the determination of the conditions on the unknown parameters h_ℓ is done on matrices of smaller size (Step 7 in Algorithm 9.6 [Existence of a G -invariant cubature]).
- The computation of the nodes as generalized eigenvalues and the computation of the weights as solutions of a Vandermonde-like linear system are also performed on smaller-sized matrices (see Algorithm 9.7 [Weights & Nodes]).

To establish a methodological approach we developed several novel results:

- A basis-free version of the moment matrix approach to cubatures (Sections 3.2, 3.3 and 3.4). It allows us to use another kind of bases than the monomial bases used in [25].
- The introduction of appropriate bases, namely *orthogonal symmetry adapted bases*, such that the matrices $H_1^{B^{(\delta)}}$ are block diagonal: the size of the blocks and the number of identical blocks are deduced from the computation of those bases (Sections 6.4, 6.5 and 8.1). Previous use of symmetry adapted bases appeared in [29, 72]. However, the induced representations were required to be orthogonal and representations of symmetric groups, that permute the variables, were mostly used. This is not sufficient in our application.
- The introduction of the matrix of multiplicities Γ_G of a finite group G (Section 7). It is the key to preliminary criteria of existence of symmetric cubatures. Its computation is done for cyclic groups C_m and dihedral groups D_m with $m \geq 2$.
- The equivalence between the representation on the quotient space $\mathbb{R}[x]/I_\Lambda$ and the permutation representation on the invariant set of nodes (Section 8.2).
 - The size of the blocks of H_1^B is related to the organization of the nodes in orbit types and the matrix of multiplicities of the group of symmetry.
 - The distribution of the distinct generalized eigenvalues of the different blocks is known with respect to the organization of the nodes in orbit types.

Possible number of nodes r for a G -invariant cubature of fixed degree d are deduced. They are quantified by the inequalities (9.9) and (9.10) that play the same role as the consistency conditions in [69].

An algorithm for computing G -invariant cubatures is presented (Section 9) and applied to recover known cubatures (Section 9.4) and exhibit new cubatures: D_6 -invariant cubatures of degree 13 with 37 nodes for the regular hexagon H_2 (Section 10).

2.6 Related problems

The techniques presented in this paper have other applications than cubatures. Indeed, a number of classical problems can be formulated as we did for quadratures, in the univariate case, and cubatures, in the multivariate case.

In the univariate case, one seeks to retrieve pairs $\{(a_1, \xi_1), \dots, (a_r, \xi_r)\}$ from the *moments* $(\mu_k)_{k \in \mathbb{N}}$ or $(\mu_k)_{0 \leq k \leq R}$ under the assumption that

$$\mu_k = \sum_{j=1}^r a_j \xi_j^k.$$

In the case of quadratures, $\mu_k \in \mathbb{R}$ and we expect a_j and ξ_j to be in \mathbb{R} . In general though μ_k , a_j and ξ_j are in \mathbb{C} . Furthermore, the number of terms r might be an additional unknown of the problem. As demonstrated above the problem can be solved (uniquely) when $R = 2r - 1$ moments are available.

In the multivariate cases, the input is indexed by $k = (k_1, \dots, k_n) \in \mathbb{N}^n$ and each ξ_j belongs to \mathbb{C}^n . The relationships are given by

$$\mu_k = \sum_{j=1}^r a_j \xi_{j,1}^{k_1} \dots \xi_{j,n}^{k_n}.$$

An additional problem in the multivariate case, even when r is known, is to find an appropriate \mathbb{K} -vector space basis of the quotient algebra $\mathbb{K}[x_1, \dots, x_n]/I_\xi$, where I_ξ is the ideal the variety of which is $\{\xi_1, \dots, \xi_r\} \subset \mathbb{C}^n$.

Prony's method for exponential interpolation [71].

One wants to retrieve $f : \mathbb{C} \rightarrow \mathbb{C}$ as

$$f(x) = \sum_{j=1}^r a_j e^{\lambda_j x}$$

from the knowledge of $\mu_k = f(k)$ with $k \in \mathbb{N}$. One retrieves the above problem by considering $\xi_j = e^{\lambda_j}$.

In its multivariate version $f : \mathbb{C}^n \rightarrow \mathbb{C}$ and

$$f(x) = \sum_{j=1}^r a_j e^{\langle \lambda_j, x \rangle}$$

where $x = (x_1, \dots, x_n)$, $\lambda_j \in \mathbb{C}^n$ and $\langle y, x \rangle = y_1 x_1 + \dots + y_n x_n$. With $\xi_{j1} = e^{\lambda_{j1}}$, \dots , $\xi_{jn} = e^{\lambda_{jn}}$ the problem is then recast into

$$f(x) = \sum_{j=1}^r a_j \xi_j^x.$$

Under some natural assumptions, solutions have been proposed for the univariate case [65], for the multivariate case with a univariate resolution (projection method) [66] and with a multivariate approach [47].

Sparse interpolation [8].

Assuming a (multivariate) polynomial has a small support,

$$f(x) = \sum_{j=1}^r a_j x^{\alpha_j}$$

one wishes to retrieve the exponents $\alpha_j \in \mathbb{N}^n$ from evaluations of the polynomial at chosen points. For $k \in \mathbb{N}$, one chooses $\mu_k = f(p_1^k, \dots, p_n^k)$ where p_j are distinct prime numbers. From μ_0, \dots, μ_{2r-1} one can retrieve $\xi_j = p^{\alpha_j} = p_1^{\alpha_{j1}} \dots p_n^{\alpha_{jn}}$ so that the exponent can be found by factorization [8, 45, 46]. Replacing the prime numbers by roots of unity, the authors in [31] proposed a symbolic-numeric solution.

For latest development in Prony's method and sparse interpolation, one can consult the material attached to the 2015 Dagstuhl seminar *Sparse modelling and multi-exponential analysis* (<http://www.dagstuhl.de/15251>).

Pole estimation, Padé approximant [39].

The input data are the coefficients of the Taylor expansion at $z = 0$ of a function $f : \mathbb{C} \rightarrow \mathbb{C}$ and one wishes to find the poles of the function.

$$f(x) = \sum_{j=1}^r \frac{a_j}{1 - \xi_j x} = \sum_{k \in \mathbb{N}} \mu_k x^k.$$

The multivariate version that can be approached is

$$f(x) = \sum_{j=1}^r \frac{a_j}{\langle \xi_j, x \rangle} = \sum_{k \in \mathbb{N}^n} \mu_k x^k.$$

In the univariate case all polynomials can be factored over \mathbb{C} into degree 1 polynomials. Therefore the problem covers all rational functions with distinct poles. The restriction to denominators that can be factored into linear form is more restrictive in the multivariate case.

Shape-from-moment problem [33, 62].

The problem consists in recovering the vertices of a convex n -dimensional polytope \mathcal{V} from its moments. *Projection methods* have been developed in [12, 33] based on moments in a direction $\delta \in \mathbb{R}^n$ and Brion's identities

$$\left\{ \begin{array}{l} \frac{(k+n)!}{k!} \int_{\mathcal{V}} \langle x, \delta \rangle^k dx = \sum_{j=1}^r a_j \langle v_j, \delta \rangle^{n+k} \quad k \geq 0 \\ 0 = \sum_{j=1}^r a_j \langle v_j, \delta \rangle^{n-k} \quad 1 \leq k \leq n. \end{array} \right.$$

The coefficients a_j are nonzero real numbers and $\langle v_j, \delta \rangle$ are the projections of the vertices v_j on the direction δ . Taking $\xi_j = \langle v_j, \delta \rangle$, the formula can be recast into

$$\mu_k = \sum_{j=1}^r a_j \xi_j^k \quad k \in \mathbb{N},$$

where μ_k is related to the left hand side of the system of equations above. The set of projected vertices can thus be recovered. Different projections are then required and matching processes are presented in [12, 33]. The case $n = 2$ treated with complex moments in [21, 22, 62] is linked to this general case in [12].

A multidimensional treatment of the shape-from-moment problem is however impossible due to the lack, up to our knowledge, of an equivalent formula for the moments $\int_{\mathcal{Y}} x^k dx$ with $k \in \mathbb{N}^n$.

Symmetric tensor decomposition [10].

The general (multivariate) problem is to find, for a homogeneous polynomial

$$f(z) = \sum_{|k|=d} \binom{d}{k} \mu_k z^k,$$

the minimal *rank* r such that there exist $(a_1, \xi_1), \dots, (a_r, \xi_r) \in \mathbb{C} \times \mathbb{C}^n$ such that f can be written as a linear combination of linear forms to the d^{th} power:

$$f(z) = \sum_{i=1}^r a_i \langle \xi_i, z \rangle^d.$$

Dehomogenizing the binary case ($n = 2$), we obtain an equivalent univariate problem

$$f(z) = \mu_d z^d + \dots + \binom{d}{k} \mu_k z^k + \dots + \mu_0 = \sum_{i=1}^r a_i (1 - \xi_i z)^d$$

initially solved by Sylvester [80].

Orthogonal polynomials

As seen in the previous section, quadrature is intimately linked with orthogonal polynomials. The nodes of the quadrature of degree $2d - 1$ are the d roots of the orthogonal polynomial of degree d .

One can see that, for a measure μ on \mathbb{R}^n , there is a Gaussian cubature of degree $2d - 1$ if and only if all the orthogonal polynomials of degree d admit $\dim R[x]_{\leq d-1}$ common zeros.

Orthogonal polynomials are obtained, for instance, by diagonalizing the moment matrix, or more generally the Gram matrix for other polynomial bases than monomial bases. In our approach to symmetric cubature, we show that if the linear form Λ is G -invariant the orthogonal symmetry adapted bases provides a block diagonal Gram matrix. By further refining this diagonalization, we obtain a symmetry adapted basis of orthogonal polynomials.

3 Hankel operators and flat extension of moment matrices

We review in this section two major ingredients for a constructive approach to cubatures.

To a linear form Λ on $\mathbb{K}[x]$ ($\mathbb{K} = \mathbb{R}$ or \mathbb{C}) we associate a Hankel operator $\mathbb{K}[x] \rightarrow \mathbb{K}[x]^*$. The Hankel operator allows to study the properties of the linear form Λ . When $\mathbb{K} = \mathbb{R}$, the linear form corresponds to a linear combination of evaluations at some points if and only if the associated Hankel operator is of finite rank and positive semidefinite. The kernel of the operator is furthermore the vanishing ideal of those points. It is thus possible to use classical methods from algebraic geometry to obtain information on its variety [17, 23].

Given a linear form $\Lambda^{(\delta)}$ on $\mathbb{R}[x]_{\leq 2\delta}$ for a certain degree δ , the flat extension criterion provides a sufficient condition for the existence of a unique extension Λ of $\Lambda^{(\delta)}$ to $\mathbb{R}[x]$. Its Hankel operator is of finite rank. It is furthermore positive semidefinite if the one associated with $\Lambda^{(\delta)}$ is positive semidefinite.

The concept of flat extension was introduced by Curto and Fialkow in the context of moment matrices [18, 19]. Those can be understood as the matrices of the Hankel operators in monomial bases. We recast the results in a basis-free version so that arbitrary bases can be used.

Flat extension were introduced as a mean to answer the classical truncated moment problem [18, 19]. The problem has applications in global optimization through the relaxation techniques introduced by Lasserre [48, 49]. The successful line of developments in this area were surveyed by Laurent [56]. This book chapter presents the foundational results with simplified and algebraic proofs; it served us as reference.

Several other problems can be approached with flat extension techniques, as for instance tensor decomposition [10, 9] and computation of real radicals [51, 52, 53]. The link between cubatures and flat extensions was first expanded on in [25] and leads to a new lower bound on the number of nodes of a minimal cubature formulae. In [50] the flat extension formalism is applied to give a new criterion for the existence of Gaussian cubature.

3.1 Zero-dimensional ideals

A set of points in \mathbb{K}^n can be characterized as the variety of a certain radical zero-dimensional ideal I in $\mathbb{K}[x]$. We recall in this section results that link ideals and varieties. The multiplication operator in the quotient space $\mathbb{K}[x]/I$ is of particular interest. Its eigenvalues and left eigenvectors are in one-to-one correspondance with the points of the variety of I .

Given an ideal I in $\mathbb{K}[x]$, its variety is understood in \mathbb{C}^n and is denoted by $V_{\mathbb{C}}(I)$.

Theorem 3.1 ([17, Finiteness Theorem]). *Let $I \subset \mathbb{K}[x]$ be an ideal. Then the following conditions are equivalent:*

- *The algebra $\mathcal{A} = \mathbb{K}[x]/I$ is finite-dimensional as a \mathbb{K} -vector space.*
- *The variety $V_{\mathbb{C}}(I) \subset \mathbb{C}^n$ is a finite set.*

An ideal I satisfying any of the above conditions is said to be *zero-dimensional*. In this case, Theorem 3.2 relates the dimension of the algebra $\mathbb{K}[x]/I$ to the cardinal of the variety $V_{\mathbb{C}}(I)$.

Theorem 3.2 ([17, Theorem 2.10]). *Let I be a zero-dimensional ideal in $\mathbb{K}[x]$ and let $\mathcal{A} = \mathbb{K}[x]/I$. Then $\dim_{\mathbb{K}}(\mathcal{A})$ is greater than or equal to the number of points in $V_{\mathbb{C}}(I)$. Equality occurs if and only if I is a radical ideal.*

Assume that the algebra $\mathbb{K}[x]/I$ is a finite-dimensional \mathbb{K} -vector space. The class of any polynomial $f \in \mathbb{K}[x]$ modulo I is denoted by $[f]$. Given a polynomial $p \in \mathbb{K}[x]$, the map

$$\mathcal{M}_p : \mathbb{K}[x]/I \rightarrow \mathbb{K}[x]/I, [f] \mapsto [fp]$$

is a linear map called *multiplication by p* . The following result relates the eigenvalues of the multiplication operators in $\mathbb{K}[x]/I$ to the variety $V_{\mathbb{C}}(I)$. This result underlies the eigenvalue method for solving polynomial equations.

Theorem 3.3 ([17, Theorem 4.5]). *Let I be a zero-dimensional ideal in $\mathbb{K}[x]$ and let $p \in \mathbb{K}[x]$. Then, for $\lambda \in \mathbb{C}$, the following are equivalent:*

- λ is an eigenvalue of the multiplication operator \mathcal{M}_p .
- λ is a value of the function p on $V_{\mathbb{C}}(I)$.

Given a basis B of $\mathbb{K}[x]/I$, the matrix of the multiplication operator \mathcal{M}_p in the basis B is denoted by M_p^B . There is a strong connection between the points of $V_{\mathbb{C}}(I)$ and the left eigenvectors of the matrix M_p^B relative to a basis B of $\mathbb{K}[x]/I$. We will assume that I is radical. In this case, Theorem 3.2 implies that $\mathbb{K}[x]/I$ has dimension r , where r is the number of distinct points in $V_{\mathbb{C}}(I)$.

Theorem 3.4. *Let I be a zero-dimensional and radical ideal in $\mathbb{K}[x]$, let ξ_1, \dots, ξ_r be the points of $V_{\mathbb{C}}(I) \subset \mathbb{K}^n$ and let b_1, \dots, b_r be polynomials in $\mathbb{K}[x]$. Then the following conditions are equivalent:*

- The set $B = \{[b_1], \dots, [b_r]\}$ is a basis of $\mathbb{K}[x]/I$.
- The matrix $W = (b_j(\xi_i))_{1 \leq i, j \leq r}$ is invertible.

Assume that any of the above conditions is satisfied. Let p be a polynomial in $\mathbb{K}[x]$, let M_p^B be the matrix of the multiplication operator \mathcal{M}_p in the basis B and let D be the diagonal matrix whose diagonal elements are $p(\xi_1), \dots, p(\xi_r)$. Then

$$WM_p^B = DW.$$

In other words, a left eigenvector associated to the eigenvalue $p(\xi_i)$ is given by the row vector $(b_1(\xi_i) \ \dots \ b_r(\xi_i))$.

Proof. Let $\alpha = (\alpha_1, \dots, \alpha_r) \in \mathbb{K}^r$ such that $\alpha_1 b_1 + \dots + \alpha_r b_r \equiv 0 \pmod{I}$. Since $V_{\mathbb{C}}(I) = \{\xi_1, \dots, \xi_r\}$, we have

$$\alpha_1 b_1(\xi_i) + \dots + \alpha_r b_r(\xi_i) = 0 \quad \forall i = 1, \dots, r.$$

With the help of the matrix $W = (b_j(\xi_i))_{1 \leq i, j \leq r}$, this equality can be rewritten as $W\alpha = 0$. Thus, the matrix W is invertible if and only if $(\alpha_1, \dots, \alpha_r) = (0, \dots, 0)$. This means that W is

invertible if and only if b_1, \dots, b_r are linearly independent modulo I . Since $\text{Card } B = \dim \mathbb{K}[x]/I$, we have that W is invertible if and only if B is a basis of $\mathbb{K}[x]/I$.

Assume now that B is a basis of $\mathbb{K}[x]/I$. Let $M_p^B = (m_{ij})_{1 \leq i, j \leq r}$ be the matrix in the basis B of the multiplication operator \mathcal{M}_p from $\mathbb{K}[x]/I$ to itself. By definition of the multiplication operator \mathcal{M}_p , we have

$$pb_j \equiv \sum_{k=1}^r m_{kj} b_k \pmod{I} \quad \forall j = 1, \dots, r.$$

Since ξ_i is a point of the variety $V_{\mathbb{C}}(I)$, evaluating this equality at a point ξ_i brings

$$p(\xi_i)b_j(\xi_i) = \sum_{k=1}^r m_{kj} b_k(\xi_i) \quad \forall j = 1, \dots, r,$$

which can be rewritten as

$$p(\xi_i) \begin{pmatrix} b_1(\xi_i) & \dots & b_r(\xi_i) \end{pmatrix} = \begin{pmatrix} b_1(\xi_i) & \dots & b_r(\xi_i) \end{pmatrix} M_p^B.$$

Since this equality holds for every $\xi_i \in V_{\mathbb{C}}(I)$, we have then

$$WM_p^B = DW.$$

□

With the help of the matrix W defined in Theorem 3.4, the next result introduces polynomials f_1, \dots, f_r that satisfy $f_j(\xi_i) = \delta_{ij}$ for all $\xi_i \in V_{\mathbb{C}}(I)$. The polynomials f_1, \dots, f_r (resp. the matrix W) can be considered as a generalization of the Lagrange polynomials (resp. the Vandermonde matrix) used in polynomial interpolation when $n = 1$. Notice that polynomials f_1, \dots, f_r which satisfy $f_j(\xi_i) = \delta_{ij}$ are generally not unique.

Corollary 3.5. *Let I be a zero-dimensional and radical ideal in $\mathbb{K}[x]$, let ξ_1, \dots, ξ_r be the points of $V_{\mathbb{C}}(I)$, let b_1, \dots, b_r be polynomials in $\mathbb{K}[x]$ such that the set $B = \{[b_1], \dots, [b_r]\}$ is a basis of $\mathbb{K}[x]/I$ and let W be the matrix $W = (b_j(\xi_i))_{1 \leq i, j \leq r}$.*

Assume that $V_{\mathbb{C}}(I) \subset \mathbb{K}^n$. Then there exist r polynomials f_1, \dots, f_r in $\mathbb{K}[x]$ determined by

$$W^t \begin{pmatrix} f_1 \\ \vdots \\ f_r \end{pmatrix} = \begin{pmatrix} b_1 \\ \vdots \\ b_r \end{pmatrix}$$

and satisfying $f_i(\xi_j) = \delta_{ij}$. Moreover, the set $\{[f_1], \dots, [f_r]\}$ is a basis of $\mathbb{K}[x]/I$.

Proof. By Theorem 3.4, since B is a basis of $\mathbb{K}[x]/I$, the matrix W is invertible so that the polynomials f_1, \dots, f_r in $\mathbb{K}[x]$ are determined uniquely by

$$\begin{pmatrix} f_1 \\ \vdots \\ f_r \end{pmatrix} = W^{-t} \begin{pmatrix} b_1 \\ \vdots \\ b_r \end{pmatrix}. \tag{3.1}$$

Let e_j be the j^{th} vector of the canonical basis of \mathbb{K}^r . By definition of the matrix W , we have

$$W^t e_j = \begin{pmatrix} b_1(\xi_j) \\ \vdots \\ b_r(\xi_j) \end{pmatrix} \quad \forall j = 1, \dots, r.$$

From the definition of the polynomials f_1, \dots, f_r , we deduce that they satisfy $f_i(\xi_j) = \delta_{ij}$.

Let $\alpha_1, \dots, \alpha_r \in \mathbb{K}$ such that

$$\alpha_1 f_1 + \dots + \alpha_r f_r \equiv 0 \pmod{I}.$$

Take $\beta_1, \dots, \beta_r \in \mathbb{K}$ such that $(\beta_1 \ \dots \ \beta_r) = (\alpha_1 \ \dots \ \alpha_r) W^{-t}$. Using the definition of the polynomials f_1, \dots, f_r , we have then

$$\beta_1 b_1 + \dots + \beta_r b_r \equiv 0 \pmod{I}.$$

Since B is a basis of $\mathbb{K}[x]/I$, we have $\beta_1 = \dots = \beta_r = 0$, or equivalently $\alpha_1 = \dots = \alpha_r = 0$. The polynomials f_1, \dots, f_r are then linearly independent modulo I . Finally, since $\dim \mathbb{K}[x]/I = r$, the set $\{[f_1], \dots, [f_r]\}$ is a basis of $\mathbb{K}[x]/I$. \square

3.2 Hankel operators of finite rank

After a short description of the dual space of the polynomial space $\mathbb{K}[x]$, we associate a Hankel operator to any of its elements. The Hankel operator is our main theoretical object to study the properties of its linear form. From a Hankel operator defined on the whole polynomial space $\mathbb{K}[x]$, we construct linear operators on finite dimensional spaces. The kernel of the Hankel operator is fundamental in characterizing the linear form.

Linear forms

The set of \mathbb{K} -linear forms from $\mathbb{K}[x]$ to \mathbb{K} is denoted by $\mathbb{K}[x]^*$ and called the *dual space* of $\mathbb{K}[x]$. Typical examples of linear forms on $\mathbb{K}[x]$ are the evaluations $\mathbb{1}_\xi$ at a point ξ of \mathbb{K}^n . They are defined by

$$\mathbb{1}_\xi : \mathbb{K}[x] \rightarrow \mathbb{K}, p \mapsto p(\xi).$$

Other examples of linear forms on $\mathbb{K}[x]$ are given by linear combination of evaluations

$$\Lambda : \mathbb{K}[x] \rightarrow \mathbb{K}, p \mapsto \sum_{j=1}^r a_j \mathbb{1}_{\xi_j}(p),$$

with $a_j \in \mathbb{K} \setminus \{0\}$ and $\xi_j \in \mathbb{K}^n$, or, when $\mathbb{K} = \mathbb{R}$, by the integration over a domain $\mathcal{D} \subset \mathbb{R}^n$

$$\Omega : \mathbb{R}[x] \rightarrow \mathbb{R}, p \mapsto \int_{\mathcal{D}} p(x) dx.$$

Notice that a linear combination of evaluations corresponds to a discrete domain of integration.

Construction of Hankel operators

For any linear form $\Lambda \in \mathbb{K}[x]^*$, the associated *Hankel operator* $\widehat{\mathcal{H}}$ is the linear operator

$$\widehat{\mathcal{H}} : \mathbb{K}[x] \rightarrow \mathbb{K}[x]^*, p \mapsto p \star \Lambda,$$

where $p \star \Lambda : \mathbb{K}[x] \rightarrow \mathbb{K}, q \mapsto \Lambda(pq)$. The kernel of $\widehat{\mathcal{H}}$

$$I_\Lambda = \{p \in \mathbb{K}[x] \mid p \star \Lambda = 0\}$$

is an ideal of $\mathbb{K}[x]$ and its image is included in the subspace $(I_\Lambda)^\perp = \{\Omega \in \mathbb{K}[x]^* \mid \Omega(p) = 0 \forall p \in I_\Lambda\} \subset \mathbb{K}[x]^*$.

Let π be the natural morphism from $\mathbb{K}[x]$ onto the quotient space $\mathbb{K}[x]/I_\Lambda$, which associates to any polynomial $p \in \mathbb{K}[x]$ its class $[p]$ modulo I_Λ

$$\pi : \mathbb{K}[x] \rightarrow \mathbb{K}[x]/I_\Lambda, p \mapsto [p].$$

The linear operator $\widehat{\mathcal{H}}$ factors through the morphism $\mathring{\mathcal{H}} : \mathbb{K}[x]/I_\Lambda \rightarrow \mathbb{K}[x]^*$ defined by $\widehat{\mathcal{H}} = \mathring{\mathcal{H}} \circ \pi$. Since $\mathring{\mathcal{H}}$ is an isomorphism from $\mathbb{K}[x]/I_\Lambda$ to $\widehat{\mathcal{H}}(\mathbb{K}[x])$, the ideal I_Λ is zero-dimensional if and only if the rank of the Hankel operator $\widehat{\mathcal{H}}$ is finite, in which case $\dim \mathbb{K}[x]/I_\Lambda = \text{rank } \widehat{\mathcal{H}}$.

Assume now that the rank of the Hankel operator is finite. The morphism π induces the morphism

$$\pi_* : (\mathbb{K}[x]/I_\Lambda)^* \rightarrow (I_\Lambda)^\perp, \Omega \mapsto \Omega \circ \pi,$$

which is an isomorphism [23, Proposition 7.9]. There exists then a linear operator \mathcal{H} from the quotient space $\mathbb{K}[x]/I_\Lambda$ to its dual space $(\mathbb{K}[x]/I_\Lambda)^*$ defined by

$$\mathcal{H} : \mathbb{K}[x]/I_\Lambda \rightarrow (\mathbb{K}[x]/I_\Lambda)^*, [p] \mapsto (\pi_*)^{-1} \circ \iota \circ \mathring{\mathcal{H}}([p]),$$

where ι is the natural inclusion from $\widehat{\mathcal{H}}(\mathbb{K}[x])$ to $(I_\Lambda)^\perp$.

$$\begin{array}{ccccc}
 \mathbb{K}[x] & \xrightarrow{\widehat{\mathcal{H}}} & \widehat{\mathcal{H}}(\mathbb{K}[x]) & \xrightarrow{\iota} & (I_\Lambda)^\perp & \xrightarrow{(\pi_*)^{-1}} & (\mathbb{K}[x]/I_\Lambda)^* \\
 \searrow \pi & & \nearrow \mathring{\mathcal{H}} & & & \nearrow \mathcal{H} & \\
 & & \mathbb{K}[x]/I_\Lambda & & & &
 \end{array}$$

Figure 1: Commutative diagram representing the construction of the linear operator \mathcal{H} .

The commutative diagram in Figure 1 helps to check that the linear operator \mathcal{H} is one-to-one by construction. Since $\dim \mathbb{K}[x]/I_\Lambda = \dim (\mathbb{K}[x]/I_\Lambda)^*$, \mathcal{H} is furthermore an isomorphism. Notice that this implies that $\widehat{\mathcal{H}}(\mathbb{K}[x]) = (I_\Lambda)^\perp$.

Matrices of Hankel operators

Given a set $B = \{b_1, \dots, b_r\} \subset \mathbb{K}[x]$ and a polynomial $p \in \mathbb{K}[x]$, we introduce the matrix

$$H_p^B = (\Lambda(b_i b_j p))_{1 \leq i, j \leq r}.$$

We relate now the matrix H_p^B , starting with the case $p = 1$, to the linear operator \mathcal{H} obtained from the Hankel operator $\widehat{\mathcal{H}}$ following the commutative diagram in Figure 1. For ease of notation, we also denote by B the set $\{[b_1], \dots, [b_r]\}$ of classes modulo I_Λ .

Theorem 3.6. *Assume that $\text{rank } \widehat{\mathcal{H}} = r < \infty$ and let $B = \{b_1, \dots, b_r\} \subset \mathbb{K}[x]$. Then B is a basis of $\mathbb{K}[x]/I_\Lambda$ if and only if the matrix H_1^B is invertible, in which case the matrix H_1^B is the matrix of the linear operator \mathcal{H} in the basis B and its dual basis B^* in $(\mathbb{K}[x]/I_\Lambda)^*$.*

Proof. Let $\alpha = (\alpha_1, \dots, \alpha_r) \in \mathbb{K}^r$ such that $\alpha_1 b_1 + \dots + \alpha_r b_r \equiv 0 \pmod{I_\Lambda}$. Using the definition of I_Λ , we get

$$\alpha_1 \Lambda(b_1 b_i) + \dots + \alpha_r \Lambda(b_r b_i) = 0 \quad \forall i = 1, \dots, r.$$

With the help of the matrix $H_1^B = (\Lambda(b_i b_j))_{1 \leq i, j \leq r}$, this equality can be rewritten as $H_1^B \alpha = 0$. Assuming that the matrix H_1^B is invertible leads to $(\alpha_1, \dots, \alpha_r) = (0, \dots, 0)$. Thus, the polynomials b_1, \dots, b_r are linearly independent modulo I_Λ . Since $\text{Card } B = \dim \mathbb{K}[x]/I_\Lambda$, the set $B = \{[b_1], \dots, [b_r]\}$ is a basis of $\mathbb{K}[x]/I_\Lambda$.

Conversely, assume that B is a basis of $\mathbb{K}[x]/I_\Lambda$. The \mathbb{K} -vector space $\mathbb{K}[x]$ is then the direct sum of the span of B and the vector space I_Λ so that $\widehat{\mathcal{H}}(\mathbb{K}[x]) = \widehat{\mathcal{H}}(\text{Span } B)$. For each $b_i \in B$, let b_i^* be the linear form in the dual space $(\text{Span } B)^*$ such that $b_i^*(b_k) = \delta_{ik}$. We have

$$\widehat{\mathcal{H}}(b_j) = \sum_{i=1}^r \Lambda(b_j b_i) b_i^* \quad \forall b_j \in B \quad (3.2)$$

since

$$\widehat{\mathcal{H}}(b_j)(b_k) = \Lambda(b_j b_k) = \left(\sum_{i=1}^r \Lambda(b_j b_i) b_i^* \right) (b_k) \quad \forall b_k \in B,$$

Equation (3.2) shows that $\widehat{\mathcal{H}}(\text{Span } B) \subset \text{Span}(b_1^*, \dots, b_r^*)$. Since $\text{rank } \widehat{\mathcal{H}} = r$, the set $\{b_1^*, \dots, b_r^*\}$ is a basis of $\widehat{\mathcal{H}}(\mathbb{K}[x])$, that is a basis of $(I_\Lambda)^\perp$. Thanks to the isomorphism π_* , the set $\{b_1^*, \dots, b_r^*\}$ is identified to the dual basis B^* in $(\mathbb{K}[x]/I_\Lambda)^*$ of the basis B in $\mathbb{K}[x]/I_\Lambda$. Thus, the matrix of the linear operator \mathcal{H} in the basis B and its dual basis B^* is the matrix H_1^B . Since \mathcal{H} is an isomorphism, the matrix H_1^B is invertible. \square

Assume that the polynomials b_1, \dots, b_r are chosen such that B is a basis of $\mathbb{K}[x]/I_\Lambda$. Consider a polynomial $p \in \mathbb{K}[x]$. The matrix $H_p^B = (\Lambda(b_i b_j p))_{1 \leq i, j \leq r}$ is similarly related to the linear operator

$$\mathcal{H}_p = \mathcal{H} \circ \mathcal{M}_p.$$

Theorem 3.7. *Assume that $\text{rank } \widehat{\mathcal{H}} = r < \infty$ and that B is a basis of $\mathbb{K}[x]/I_\Lambda$. Then, for any polynomial $p \in \mathbb{K}[x]$, the matrix H_p^B is the matrix of the linear operator $\mathcal{H} \circ \mathcal{M}_p$ in the basis B and its dual basis B^* and*

$$H_p^B = H_1^B M_p^B,$$

where M_p^B is the matrix of the multiplication operator \mathcal{M}_p in the basis B .

Proof. Let $p \in \mathbb{K}[x]$. By definition of the multiplication operator \mathcal{M}_p , we have

$$\mathcal{H} \circ \mathcal{M}_p([b_j]) = \mathcal{H}([b_j p]) \quad \forall j = 1, \dots, r.$$

As in the proof of Theorem 3.6, we introduce the linear forms b_1^*, \dots, b_r^* on $\text{Span } B$. Equation (3.2) leads to the following equality

$$\widehat{\mathcal{H}}(b_j p) = \sum_{i=1}^r \Lambda(b_i b_j p) b_i^* \quad \forall j = 1, \dots, r. \quad (3.3)$$

Since $\widehat{\mathcal{H}}([b_j p]) = \widehat{\mathcal{H}}(b_j p)$ for all $b_j \in B$ and thanks to the isomorphism π_* , we deduce from (3.3) that the matrix $H_1^B M_p^B$ of the operator $\mathcal{H} \circ \mathcal{M}_p$ in the basis B and its dual basis B^* is $(\Lambda(b_i b_j p))_{1 \leq i, j \leq r}$. The latter is by definition the matrix H_p^B . \square

The next result shows the change of basis relation for the matrices of the linear operators \mathcal{H}_p .

Corollary 3.8. *Let b_1, \dots, b_r be polynomials in $\mathbb{K}[x]$ such that $B = \{[b_1], \dots, [b_r]\}$ is basis of $\mathbb{K}[x]/I_\Lambda$ and let $\tilde{b}_1, \dots, \tilde{b}_r$ be polynomials in $\mathbb{K}[x]$ given by*

$$\begin{pmatrix} \tilde{b}_1 \\ \vdots \\ \tilde{b}_r \end{pmatrix} = Q \begin{pmatrix} b_1 \\ \vdots \\ b_r \end{pmatrix},$$

where $Q = (q_{ij})_{1 \leq i, j \leq r}$ is an invertible matrix. Then $\tilde{B} = \{[\tilde{b}_1], \dots, [\tilde{b}_r]\}$ is a basis of $\mathbb{K}[x]/I_\Lambda$ and, given a polynomial $p \in \mathbb{K}[x]$, the matrix $H_p^{\tilde{B}}$ satisfies

$$H_p^{\tilde{B}} = Q H_p^B Q^t.$$

Proof. On one hand, for every $i = 1, \dots, r$, we have by definition $\tilde{b}_i = \sum_{k=1}^r q_{ik} b_k$. Applying this to the entries of the matrix $H_p^{\tilde{B}}$ brings

$$\Lambda(\tilde{b}_i \tilde{b}_j p) = \sum_{k=1}^r q_{ik} \Lambda(b_k \tilde{b}_j p) = \sum_{1 \leq k, \ell \leq r} q_{ik} q_{j\ell} \Lambda(b_k b_\ell p) \quad \forall 1 \leq i, j \leq r.$$

Thus, we have

$$H_p^{\tilde{B}} = \left(\sum_{1 \leq k, \ell \leq r} q_{ik} q_{j\ell} \Lambda(b_k b_\ell p) \right)_{1 \leq i, j \leq r}.$$

On the other hand, we have

$$\begin{aligned} Q H_p^B Q^t &= (q_{ij})_{1 \leq i, j \leq r} (\Lambda(b_i b_j p))_{1 \leq i, j \leq r} (q_{ij})_{1 \leq i, j \leq r}^t \\ &= (q_{ij})_{1 \leq i, j \leq r} \left(\sum_{\ell=1}^r q_{j\ell} \Lambda(b_i b_\ell p) \right)_{1 \leq i, j \leq r} \\ &= \left(\sum_{1 \leq k, \ell \leq r} q_{ik} q_{j\ell} \Lambda(b_k b_\ell p) \right)_{1 \leq i, j \leq r}. \end{aligned}$$

Comparing the two matrices leads to the expected result

$$H_p^{\tilde{B}} = Q H_p^B Q^t. \quad \square$$

For any polynomial $p \in \mathbb{K}[x]$, we can deduce from Theorem 3.6 and Theorem 3.7 a way to compute the values of the polynomial p on the variety $V_{\mathbb{C}}(I_{\Lambda})$. Indeed, since B is a basis of $\mathbb{K}[x]/I_{\Lambda}$, Theorem 3.6 says that the matrix H_1^B is invertible and Theorem 3.7 says that $H_p^B = H_1^B M_p^B$. Thus, the eigenvalue problem of the matrix M_p^B is equivalent to the generalized eigenvalue problem of the pair of matrices (H_p^B, H_1^B) . Theorem 3.3 leads then to the following result:

Corollary 3.9. *Assume that $\text{rank } \widehat{\mathcal{H}} = r < \infty$. Let B be a basis of $\mathbb{K}[x]/I_{\Lambda}$, let $p \in \mathbb{K}[x]$ and let H_1^B and H_p^B be the matrices as defined above. Then the generalized eigenvalues of the pair (H_p^B, H_1^B) are the values of p on $V_{\mathbb{C}}(I_{\Lambda})$.*

This last result relates the variety $V_{\mathbb{C}}(I_{\Lambda})$ to the matrices of the linear operators \mathcal{H} and \mathcal{H}_p associated with the linear form Λ on $\mathbb{K}[x]$ in a basis B of $\mathbb{K}[x]/I_{\Lambda}$. Similarly to the eigenvalue method for solving polynomial equations that use the eigenvalues of the multiplication operators \mathcal{M}_p for appropriate polynomials $p \in \mathbb{K}[x]$, the generalized eigenvalues of $(\mathcal{H}_p, \mathcal{H})$ help us in the study of the variety $V_{\mathbb{C}}(I_{\Lambda})$.

Another characterization of the zero-dimensional ideal I_{Λ} is given in the next result. Its proof is based on the one of Theorem 5.19 in [55].

Proposition 3.10. *Let Λ be a linear form on $\mathbb{K}[x]$ with $\text{rank } \widehat{\mathcal{H}} = r < \infty$. Let b_1, \dots, b_r be polynomials in $\mathbb{K}[x]$ such that $B = \{[b_1], \dots, [b_r]\}$ is a basis of $\mathbb{K}[x]/I_{\Lambda}$. Assume that the polynomials b_1, \dots, b_r are in $\mathbb{K}[x]_{\leq \delta-1}$. Then the ideal generated by the kernel of the restriction $\mathcal{H}^{(\delta)}$ of $\widehat{\mathcal{H}}$ to $\mathbb{K}[x]_{\leq \delta}$ is the ideal I_{Λ} , that is*

$$I_{\Lambda} = \left(\ker \mathcal{H}^{(\delta)} \right).$$

Proof. Since $\mathcal{H}^{(\delta)}$ is a restriction of the Hankel operator $\widehat{\mathcal{H}}$, we have $\ker \mathcal{H}^{(\delta)} \subset I_{\Lambda}$, implying

$$\left(\ker \mathcal{H}^{(\delta)} \right) \subset I_{\Lambda}.$$

To show the reverse inclusion, we first show using induction on $|\beta|$ that, for all $\beta \in \mathbb{N}^n$,

$$x^{\beta} \in \text{Span}(b_1, \dots, b_r) + \left(\ker \mathcal{H}^{(\delta)} \right). \quad (3.4)$$

Since b_1, \dots, b_r are polynomials in $\mathbb{K}[x]_{\leq \delta-1}$ such that $\{[b_1], \dots, [b_r]\}$ is a basis of $\mathbb{K}[x]/I_{\Lambda}$, those polynomials form a basis of the image of $\mathcal{H}^{(\delta)}$. Thus, if $|\beta| \leq \delta$, (3.4) holds. Assume $|\beta| \geq \delta + 1$. Then

$$x^{\beta} = x_j x^{\gamma} \text{ with } |\gamma| = |\beta| - 1 \text{ and } j \in \{1, \dots, n\}.$$

By the induction assumption,

$$x^{\beta} = x_j \left(\sum_{i=1}^r \lambda_i b_i + q \right) = \sum_{i=1}^r \lambda_i x_j b_i + x_j q$$

with $q \in (\ker \mathcal{H}^{(\delta)})$. Since $x_j b_i \in \mathbb{K}[x]_{\leq \delta}$ and $x_j q \in (\ker \mathcal{H}^{(\delta)})$, we have

$$x^{\beta} \in \text{Span}(b_1, \dots, b_r) + \left(\ker \mathcal{H}^{(\delta)} \right).$$

Thus, (3.4) holds for all $\beta \in \mathbb{N}^n$.

Take $p \in I_\Lambda$. In view of (3.4), we can write $p = u + v$ with $u \in \text{Span}(b_1, \dots, b_r)$ and $v \in (\ker \mathcal{H}^{(\delta)}) \subset I_\Lambda$. Hence, $p - v \in \text{Span}(b_1, \dots, b_r) \cap I_\Lambda$, which implies $p - v = 0$. Therefore, $p \in (\ker \mathcal{H}^{(\delta)})$, which concludes the proof for equality $I_\Lambda = (\ker \mathcal{H}^{(\delta)})$. \square

Proposition 3.10 prepares for the *Flat extension theorem* in Section 3.4: it says that the information concerning I_Λ , the kernel of the Hankel operator $\widehat{\mathcal{H}}$ on the whole polynomial space $\mathbb{K}[x]$, is contained in the kernel of $\mathcal{H}^{(\delta)}$, the restriction of $\widehat{\mathcal{H}}$ to $\mathbb{K}[x]_{\leq \delta}$ for a well-chosen degree δ . In other words, if one can choose a degree δ as in Proposition 3.10, then the study of I_Λ can be done thanks to the matrix $H_1^{B^{(\delta)}} = (\Lambda(b_i b_j))_{1 \leq i, j \leq r_\delta}$, where $B^{(\delta)} = \{b_1, \dots, b_{r_\delta}\}$ is a basis of $\mathbb{K}[x]_{\leq \delta}$.

3.3 Kernels of Hankel operators and radical ideals

We show here how to recover a linear form from its Hankel operator, when this latter is of finite rank. We assume now that the zero-dimensional ideal I_Λ is radical.

Thanks to the structure theorem [23, Theorem 7.34], when the ideal I_Λ is zero-dimensional, the space $(I_\Lambda)^\perp$ is the direct sum of subspaces (of dimension ≥ 1) and each subspace depends on a point of $V_{\mathbb{C}}(I_\Lambda)$. Assume that the ideal is furthermore radical. Since the spaces $(I_\Lambda)^\perp$ and $\mathbb{K}[x]/I_\Lambda$ are isomorphic,

$$\dim (I_\Lambda)^\perp = \dim \mathbb{K}[x]/I_\Lambda = r.$$

Thus, each subspace is of dimension 1 and is spanned by the evaluation $\mathbb{1}_{\xi_j}$ at a point ξ_j of $V_{\mathbb{C}}(I_\Lambda)$. The linear form Λ , which belongs to $(I_\Lambda)^\perp$, can then be expressed in a simple way as described in the following result:

Theorem 3.11. *Assume that $\text{rank } \widehat{\mathcal{H}} = r < \infty$. Then the following conditions are equivalent:*

- *The ideal I_Λ is radical.*
- $\Lambda = \sum_{j=1}^r a_j \mathbb{1}_{\xi_j}$ with $a_j \in \mathbb{C} \setminus \{0\}$ and $\xi_j \in \mathbb{C}^n$ pairwise distinct.

If any of the above conditions is satisfied, then $V_{\mathbb{C}}(I_\Lambda) = \{\xi_1, \dots, \xi_r\}$.

Proof. Assume that $\Lambda = \sum_{j=1}^r a_j \mathbb{1}_{\xi_j}$ with $a_j \in \mathbb{C} \setminus \{0\}$ and $\xi_j \in \mathbb{C}^n$ pairwise distinct. Let

$I(\xi_1, \dots, \xi_r)$ be the ideal of polynomials vanishing at the points ξ_1, \dots, ξ_r . By the *Strong Nullstellensatz* [17, Chapter 1.4], the ideal $I(\xi_1, \dots, \xi_r)$ is radical. Let $f \in I(\xi_1, \dots, \xi_r)$, then

$$\Lambda(f) = \sum_{j=1}^r a_j f(\xi_j) = 0.$$

Thus, $I(\xi_1, \dots, \xi_r) \subset I_\Lambda$. Assume that there exists $q \in I_\Lambda$ such that $q \notin I(\xi_1, \dots, \xi_r)$, which means that there exists ξ_j such that $q(\xi_j) \neq 0$. Since the ideal $I(\xi_1, \dots, \xi_r)$ is zero-dimensional

and radical, Corollary 3.5 implies that there exist polynomials f_1, \dots, f_r satisfying $f_i(\xi_j) = \delta_{ij}$. Then we have $\Lambda(qf_i) = a_i q(\xi_i) \neq 0$, which leads to a contradiction. Thus, $I_\Lambda = I(\xi_1, \dots, \xi_r)$ and the ideal I_Λ is radical. \square

The polynomials introduced in Corollary 3.5 give particular bases of the quotient space $\mathbb{K}[x]/I_\Lambda$.

Corollary 3.12. *Assume that the ideal I_Λ is zero-dimensional and radical and that $V_{\mathbb{C}}(I_\Lambda) = \{\xi_1, \dots, \xi_r\} \subset \mathbb{K}^n$. Let f_1, \dots, f_r be polynomials as in Corollary 3.5 and denote by C the basis $\{[f_1], \dots, [f_r]\}$ of $\mathbb{K}[x]/I_\Lambda$. Then, for any polynomial $p \in \mathbb{K}[x]$,*

$$H_p^C = (\Lambda(f_i f_j p))_{1 \leq i, j \leq r} = \begin{pmatrix} a_1 p(\xi_1) & 0 & \dots & 0 \\ 0 & \ddots & \ddots & \vdots \\ \vdots & & \ddots & 0 \\ 0 & \dots & 0 & a_r p(\xi_r) \end{pmatrix}.$$

The assumption $V_{\mathbb{C}}(I_\Lambda) \subset \mathbb{K}^n$ in this last result leads to $a_j \in \mathbb{K} \setminus \{0\}$ since $\Lambda(f_j) = a_j$ for all $j = 1, \dots, r$.

In the case $\mathbb{K} = \mathbb{R}$, a sufficient condition for $V_{\mathbb{C}}(I_\Lambda) \subset \mathbb{R}^n$ is given in [55, Lemma 5.2] by the positive semidefiniteness of the Hankel operator $\widehat{\mathcal{H}}$ (see also [18, 54, 63]). Combining this result with Theorem 3.11, we get:

Proposition 3.13. *Let Λ be a linear form on $\mathbb{R}[x]$. If the Hankel operator $\widehat{\mathcal{H}}$ is positive semidefinite and $\text{rank } \widehat{\mathcal{H}} = r < \infty$, then the ideal I_Λ is radical and $V_{\mathbb{C}}(I_\Lambda) \subset \mathbb{R}^n$. Thus,*

$$\Lambda = \sum_{j=1}^r a_j \mathbb{1}_{\xi_j}$$

with $a_j > 0$ and $\xi_j \in \mathbb{R}^n$ pairwise distinct.

The fact that the coefficients a_j are positive in Proposition 3.13 is a consequence of Corollary 3.12: taking $p = 1$, since the Hankel operator $\widehat{\mathcal{H}}$ is positive semidefinite, we get $a_j > 0$.

Conversely, if the coefficients a_j are positive, then the Hankel operator $\widehat{\mathcal{H}}$ is positive semidefinite as well as the linear operators \mathcal{H} and \mathcal{H}_p for every $p \in \mathbb{R}[x]$ such that $p(\xi_j) \geq 0$ for all $j = 1, \dots, r$.

3.4 Flat extension

Our approach to cubatures is based on the extension of a linear form on $\mathbb{R}[x]_{\leq 2\delta}$ to $\mathbb{R}[x]$. The existence of such an appropriate extension is secured by *Tchakaloff's theorem* (Theorem 2.1). We present here the criteria that will be used to actually determine them.

Let $\Lambda^{(\delta)}$ be a linear form on $\mathbb{R}[x]_{\leq 2\delta}$. Similarly to Section 3.2, we associate with $\Lambda^{(\delta)}$ the Hankel operator

$$\mathcal{H}^{(\delta)} : \mathbb{R}[x]_{\leq \delta} \rightarrow \mathbb{R}[x]_{\leq \delta}^*, p \mapsto p \star \Lambda^{(\delta)}.$$

Its matrix in any basis $B^{(\delta)} = \{b_1, \dots, b_{r_\delta}\}$ of $\mathbb{R}[x]_{\leq \delta}$ and its dual basis is

$$H_1^{B^{(\delta)}} = (\Lambda(b_i b_j))_{1 \leq i, j \leq r_\delta}.$$

A linear form $\Lambda^{(\delta+\kappa)}$ on $\mathbb{R}[x]_{\leq 2\delta+2\kappa}$ is an *extension* of a given linear form $\Lambda^{(\delta)}$ on $\mathbb{R}[x]_{\leq 2\delta}$ if its restriction to $\mathbb{R}[x]_{\leq 2\delta}$ is $\Lambda^{(\delta)}$, that is if

$$\Lambda^{(\delta+\kappa)}(p) = \Lambda^{(\delta)}(p) \quad \forall p \in \mathbb{R}[x]_{\leq 2\delta}.$$

A linear form $\Lambda^{(\delta+\kappa)}$ on $\mathbb{R}[x]_{\leq 2\delta+2\kappa}$ is a *flat extension* of a given linear form $\Lambda^{(\delta)}$ if furthermore the rank of its associated Hankel operator $\mathcal{H}^{(\delta+\kappa)}$ is the rank of the Hankel operator $\mathcal{H}^{(\delta)}$ associated with the linear form $\Lambda^{(\delta)}$. In this case, $\mathcal{H}^{(\delta+\kappa)}$ is positive semidefinite if and only if $\mathcal{H}^{(\delta)}$ is positive semidefinite.

The flat extension theorem below was proved in terms of moment matrices, that is matrices $H_1^{B^{(\delta)}}$ for a monomial basis $B^{(\delta)} = \{x^\alpha \mid |\alpha| \leq \delta\}$ (see [18, 19, 54, 55]) or in terms of submatrices of those [56].

Theorem 3.14 (Flat extension theorem). *Let $\Lambda^{(\delta)}$ be a linear form on $\mathbb{R}[x]_{\leq 2\delta}$. Assume that $\Lambda^{(\delta)}$ is a flat extension of its restriction to $\mathbb{R}[x]_{\leq 2\delta-2}$. Then there exists a unique flat extension of $\Lambda^{(\delta)}$ to $\mathbb{R}[x]_{\leq 2\delta+2\kappa}$ for all $\kappa \geq 1$.*

Assume furthermore the positive semidefiniteness of the Hankel operator $\mathcal{H}^{(\delta)}$ associated with the linear form $\Lambda^{(\delta)}$ of the *Flat extension theorem*. The Hankel operator $\widehat{\mathcal{H}}$ associated with the unique flat extension Λ on $\mathbb{R}[x]$ of $\Lambda^{(\delta)}$ is also positive semidefinite. By Proposition 3.13, this linear form Λ takes a particular form. Notice that Proposition 3.10 implies that $V_{\mathbb{C}}(I_{\Lambda}) = V_{\mathbb{C}}(\ker \mathcal{H}^{(\delta)})$.

Corollary 3.15. *Let $\Lambda^{(\delta)}$ be a linear form on $\mathbb{R}[x]_{\leq 2\delta}$. Assume that $\Lambda^{(\delta)}$ is a flat extension of its restriction to $\mathbb{R}[x]_{\leq 2\delta-2}$ and that its associated Hankel operator $\mathcal{H}^{(\delta)}$ is positive semidefinite. Then the linear form Λ on $\mathbb{R}[x]$ defined by*

$$\Lambda = \sum_{j=1}^r a_j \mathbb{1}_{\xi_j},$$

with $r = \text{rank } \mathcal{H}^{(\delta)}$, $a_j > 0$ and $\{\xi_1, \dots, \xi_r\} = V_{\mathbb{C}}(\ker \mathcal{H}^{(\delta)}) \subset \mathbb{R}^n$, is the unique flat extension of $\Lambda^{(\delta)}$ to $\mathbb{R}[x]$.

In our application, we are interested in linear forms on $\mathbb{R}[x]$ of the form

$$\Lambda = \sum_{j=1}^r a_j \mathbb{1}_{\xi_j}$$

with $r > 0$, $a_j > 0$ and $\xi_j \in \mathbb{R}^n$ pairwise distinct. In addition, we expect that the points ξ_j lie in a prescribed semialgebraic set K (e.g. a triangle, a square or a disk) defined by

$$K = \{x \in \mathbb{R}^n \mid g_1(x) \geq 0, \dots, g_s(x) \geq 0\},$$

where g_1, \dots, g_s are polynomials in $\mathbb{R}[x]$.

As described in the next result, this last property can be checked thanks to the positive semidefiniteness of the linear operators $\mathcal{H}_{g_k}^{(\delta)} : \mathbb{R}[x]_{\leq \delta} \rightarrow \mathbb{R}[x]_{\leq \delta}^*$, $p \mapsto (g_k p) \star \Lambda^{(\delta)}$ for all $k = 1, \dots, s$. This result was proved with *localizing matrices*, that is the matrices of the linear operators $\mathcal{H}_{g_k}^{(\delta)}$ in a monomial basis $B^{(\delta)}$ of $\mathbb{R}[x]_{\leq \delta}$ [55, Theorem 5.23],[19].

Proposition 3.16. *Consider the semialgebraic set*

$$K = \{x \in \mathbb{R}^n \mid g_1(x) \geq 0, \dots, g_s(x) \geq 0\}.$$

Let $\kappa \in \mathbb{N}$ be such that $\kappa \geq 1$ and $2\kappa \geq \deg g_k$ for all $k = 1, \dots, s$. Let $\Lambda^{(\delta)}$ be a linear form on $\mathbb{R}[x]_{\leq 2\delta}$ and let $\Lambda^{(\delta+\kappa)} : \mathbb{R}[x]_{\leq 2\delta+2\kappa} \rightarrow \mathbb{R}$ be a flat extension of $\Lambda^{(\delta)}$. Assume that $\mathcal{H}^{(\delta)}$ and $\mathcal{H}_{g_k}^{(\delta)}$ are positive semidefinite for all $k = 1, \dots, s$. Then the linear form Λ on $\mathbb{R}[x]$ defined by

$$\Lambda = \sum_{j=1}^r a_j \mathbb{1}_{\xi_j},$$

with $r = \text{rank } \mathcal{H}^{(\delta)}$, $a_j > 0$ and $\{\xi_1, \dots, \xi_r\} = V_{\mathbb{C}}(\ker \mathcal{H}^{(\delta)}) \subset \mathbb{R}^n$, is the unique flat extension of $\Lambda^{(\delta+\kappa)}$ to $\mathbb{R}[x]$ and is such that $\xi_j \in K$.

4 Fraction-free diagonalization of positive semidefinite matrices

A symmetric matrix whose entries are polynomials in some parameters h_1, \dots, h_t over a field extension of \mathbb{Q} is considered. Based on a characterization of positive semidefinite matrices in terms of their principal minors, the goal is to diagonalize the matrix on its locus of semi-positivity. We show that Bareiss' fraction-free elimination scheme can run without pivoting to produce the expected diagonalization. The present approach is for exact arithmetic.

In this section, we present different algorithms that lead step by step to the central computational ingredient for the moment matrix approach to cubature. Starting with a characterization of positive semidefinite matrices in terms of principal minors, we deduce a first recursive procedure to check the positive semidefiniteness of symmetric matrices with real coefficients based on an analysis of the sign of the pivot at each step of a LU-decomposition. Since we are interested in matrices with polynomial entries, a fraction-free LU-decomposition is preferable. We show that Bareiss' scheme for the triangularization of a given matrix [4, 5], and more specially its revisited version for the diagonalization of a given symmetric matrix [41, 73], is compatible with our first procedure. This leads to a second procedure for symmetric matrices with entries in an integral domain of \mathbb{R} . In the case of polynomial entries over a field extension of \mathbb{Q} , we introduce a distinction between the different possible cases in the characterization in terms of principal minors. This leads to a third procedure whose output is a set of triplets: each triplet represents conditions under which the matrix in input is positive semidefinite. The number of triplets grows exponentially with the size of the matrix. When the matrix comes from the search for cubatures, this number is reduced by the problem itself. This leads to the last procedure of the section: Algorithm 4.7 [Diagonalization & Positivity with Rank Constraints].

An alternative approach, based on [6, Chapter 8.2.4], to describe the locus of semi-positivity of a $c \times c$ symmetric matrix A with entries in $\mathbb{R}[h] = \mathbb{R}[h_1, \dots, h_t]$ is to express it as a semialgebraic set. Let χ_A be the characteristic polynomial of A

$$\chi_A = X^c - \chi_1 X^{c-1} + \dots + (-1)^k \chi_k X^{c-k} + \dots + (-1)^c \chi_c,$$

where the coefficients χ_k are therefore in $\mathbb{R}[h]$ for all $k = 1, \dots, c$. Then the set of points \bar{h} in \mathbb{R}^t such that A is positive semidefinite is the semialgebraic set

$$\{\bar{h} \in \mathbb{R}^t \mid \chi_1(\bar{h}) \geq 0, \dots, \chi_c(\bar{h}) \geq 0\}.$$

If the rank r is furthermore known, then this semialgebraic set becomes

$$\{\bar{h} \in \mathbb{R}^t \mid \chi_1(\bar{h}) \geq 0, \dots, \chi_{c-r-1}(\bar{h}) \geq 0, \chi_{c-r}(\bar{h}) \geq 0, \chi_{c-r+1}(\bar{h}) = \dots = \chi_c(\bar{h}) = 0\}.$$

Finding the points in such a semialgebraic set is a central question in computational real algebraic geometry [6]. When one is interested in finding a point in this semialgebraic set, a numerical solution is provided by SemiDefinite Programming solvers. They can handle symmetric matrices with a high number of variables. Recently in [40], an exact algorithm has been proposed that decides whether this semialgebraic set is empty or not and, in the negative case, exhibits an algebraic representation of a point in this semialgebraic set. We refer also to [40, Chapter 1.2] for a state-of-the-art on this topic. In comparison, Algorithm 4.7 [Diagonalization & Positivity with Rank Constraints] provides the whole set of points and a change of basis such that the symmetric matrix becomes diagonal. However, this approach is suitable when the size of the symmetric matrix is small or reduced by block diagonalization: this is the case in the proposed search for symmetric cubatures.

4.1 Positive semidefinite matrices

A symmetric matrix $A = (a_{ij})_{1 \leq i, j \leq c}$ is called *positive semidefinite* if

$$X^t A X \geq 0 \quad \forall X \in \mathbb{R}^c.$$

It is called *positive definite* if it satisfies furthermore

$$X^t A X = 0 \Leftrightarrow X = 0.$$

Given any matrix $A = (a_{ij})_{1 \leq i, j \leq c}$, the determinant of its submatrix $A_J = (a_{ij})_{(i, j) \in J^2}$ with $J \subset \{1, \dots, c\}$ is called a *principal minor*. If the subset J satisfies furthermore $J = \{1, \dots, k\}$ with $1 \leq k \leq c$, then this determinant is called *leading principal minor*. A characterization of a positive definite (resp. semidefinite) matrix A is given in terms of its *leading principal minors* (resp. *principal minors*) as follows.

Theorem 4.1 ([84, Theorem 7.2]). *Let A be a symmetric matrix. Then*

- *A is positive definite if and only if every leading principal minor of A is positive.*
- *A is positive semidefinite if and only if every principal minor of A is nonnegative.*

With the help of Theorem 4.1, a recursive procedure based on Gaussian elimination that checks whether a symmetric matrix is positive semidefinite or not is given by the following result.

Corollary 4.2. *Let $A = (a_{ij})_{1 \leq i, j \leq c}$ be a symmetric matrix.*

1. *If A is a 1×1 matrix, then A is positive semidefinite if and only if $a_{11} \geq 0$.*
2. *Otherwise:*
 - (a) *If $a_{11} < 0$, then A is not positive semidefinite.*
 - (b) *If $a_{11} = 0$, then A is positive semidefinite if and only if $a_{1j} = 0$ for every $j = 1, \dots, c$ and the submatrix obtained by deleting the first row and the first column is positive semidefinite.*
 - (c) *If $a_{11} > 0$, then for each $i > 1$ subtract $\frac{a_{i1}}{a_{11}}$ times row 1 from row i and delete the first row and the first column. Then A is positive semidefinite if and only if the resulting matrix is positive semidefinite.*

Proof. Since the coefficient a_{11} is a principal minor, $a_{11} \geq 0$ is a necessary condition for the positive semidefiniteness of the matrix A . In the particular case of a 1×1 matrix A , this is also a sufficient condition by Theorem 4.1. It remains now to study the cases 2.(b) and 2.(c).

Assuming that $a_{11} = 0$, then we distinguish two cases:

- If $a_{1j} = 0$ for all $j = 1, \dots, c$, then every principal minor $\det A_J$ with $1 \in J$ is zero since the coefficients of a row of the matrix A_J are zero. As a consequence, A is positive semidefinite if and only if the matrix $(a_{ij})_{2 \leq i, j \leq c}$ is positive semidefinite.

- If there is a nonzero coefficient in the first row of A , that is if there exists j such that $a_{1j} \neq 0$, then the principal minor $\det \begin{pmatrix} a_{11} & a_{1j} \\ a_{j1} & a_{jj} \end{pmatrix}$ is negative since

$$\det \begin{pmatrix} a_{11} & a_{1j} \\ a_{j1} & a_{jj} \end{pmatrix} = a_{11}a_{jj} - a_{1j}a_{j1} = -a_{1j}^2 < 0.$$

Then A is not positive semidefinite.

Assuming that $a_{11} > 0$, the row operations describe the matrix equality $A = LU$, that is

$$\begin{pmatrix} a_{11} & \dots & a_{1c} \\ \vdots & & \vdots \\ a_{c1} & \dots & a_{cc} \end{pmatrix} = \begin{pmatrix} 1 & 0 & \dots & \dots & 0 \\ \frac{a_{21}}{a_{11}} & 1 & \ddots & & \vdots \\ \vdots & 0 & \ddots & \ddots & \vdots \\ \vdots & \vdots & \ddots & \ddots & 0 \\ \frac{a_{c1}}{a_{11}} & 0 & \dots & 0 & 1 \end{pmatrix} \begin{pmatrix} a_{11} & a_{12} & \dots & \dots & a_{1c} \\ 0 & \tilde{a}_{22} & \dots & \dots & \tilde{a}_{2c} \\ \vdots & \vdots & & & \vdots \\ \vdots & \vdots & & & \vdots \\ 0 & \tilde{a}_{c2} & \dots & \dots & \tilde{a}_{cc} \end{pmatrix}$$

with $\tilde{a}_{ij} = a_{ij} - \frac{a_{i1}}{a_{11}}a_{1j}$ for all $(i, j) \in \mathbb{N}^2$ such that $2 \leq i, j \leq c$.

Since we have

$$\tilde{a}_{ij} = a_{ij} - \frac{a_{i1}}{a_{11}}a_{1j} = a_{ji} - \frac{a_{1i}}{a_{11}}a_{j1} = \tilde{a}_{ji} \quad \forall 2 \leq i, j \leq c,$$

the matrix $\tilde{A} = (\tilde{a}_{ij})_{2 \leq i, j \leq c}$ is a symmetric matrix.

For every $J \subset \{1, \dots, c\}$ with $1 \in J$, we also have

$$\det A_J = \det L_J \det U_J \text{ and } \det L_J = 1$$

so that the principal minor $\det A_J$ of A is the principal minor $\det U_J$ of U .

We have furthermore that

$$\det U_J = a_{11} \det U_{J \setminus \{1\}}.$$

Since a_{11} is positive, the principal minors of U are nonnegative if and only if the ones of the matrix U without the first row and the first column are nonnegative. \square

A direct consequence is a recursive procedure based on Gaussian elimination that checks whether a symmetric matrix $A = (a_{ij})_{1 \leq i, j \leq c}$ is positive definite or not is given by:

1. If A is a 1×1 matrix, then A is positive definite if and only if $a_{11} > 0$.
2. Otherwise:
 - (a) If $a_{11} \leq 0$, then A is not positive definite.
 - (b) If $a_{11} > 0$, then for each $i > 1$ subtract $\frac{a_{i1}}{a_{11}}$ times row 1 from row i and delete the first row and the first column. Then A is positive definite if and only if the resulting matrix is positive definite.

When the matrix A depends polynomially on some parameters, one can add a case distinction at each step to provide the conditions on the parameters for the matrix to be positive semidefinite and compute the rank. However the recursive procedure in Corollary 4.2 runs then with rational functions whose numerators and denominators grow fast in degree. We therefore introduce a fraction-free variant in the next section.

4.2 Fraction-free triangularization and diagonalization

The fraction-free approach of Bareiss [4, 5] to Gaussian elimination allows a better control of the growth of the entries, whether integers or polynomials, by dividing a known extraneous factor. The intermediate results obtained at each step of elimination can actually be expressed in terms of minors of the original matrix. This gives a clear idea on the growth and the specialization property of the results. The scheme was revisited in [41, 73] for the diagonalization of symmetric matrices. For symmetric positive definite matrices, the algorithm runs without any pivoting. Based on their characterization in terms of non-negativity of the principal minors, we show that for positive semidefinite matrices we can similarly avoid any pivoting. This section was written with the help of G. Labahn.

We deal with $A = (a_{ij})_{1 \leq i, j \leq c}$ a $c \times c$ matrix with entries in an integral domain R . The description of Bareiss' algorithm requires us to introduce the following matrices and minors.

By convention, we write $A^{(0)} = A$ and $a_{0,0}^{(-1)} = 1$. Let ℓ be an integer such that $1 \leq \ell \leq c - 1$ and let

$$A^{(\ell)} = \begin{pmatrix} a_{1,1}^{(0)} & a_{1,2}^{(0)} & \cdots & \cdots & \cdots & \cdots & a_{1,c}^{(0)} \\ 0 & a_{2,2}^{(1)} & & & & & a_{2,c}^{(1)} \\ \vdots & \ddots & \ddots & & & & \vdots \\ \vdots & & \ddots & a_{\ell,\ell}^{(\ell-1)} & \cdots & \cdots & a_{\ell,c}^{(\ell-1)} \\ \vdots & & & 0 & a_{\ell+1,\ell+1}^{(\ell)} & \cdots & a_{\ell+1,c}^{(\ell)} \\ \vdots & & & \vdots & \vdots & & \vdots \\ 0 & \cdots & \cdots & 0 & a_{c,\ell+1}^{(\ell)} & \cdots & a_{c,c}^{(\ell)} \end{pmatrix}$$

$$\text{with } a_{i,j}^{(\ell)} = \det \begin{pmatrix} a_{1,1} & \cdots & a_{1,\ell} & a_{1,j} \\ \vdots & & \vdots & \vdots \\ a_{\ell,1} & \cdots & a_{\ell,\ell} & a_{\ell,j} \\ a_{i,1} & \cdots & a_{i,\ell} & a_{i,j} \end{pmatrix} \text{ for all } \ell < i, j \leq c.$$

Theorem 4.3. *Let ℓ be an integer such that $1 \leq \ell \leq c - 1$.*

1. *If $a_{k-1,k-1}^{(k-2)} \neq 0$ for all $k = 1, \dots, \ell$, then $A^{(\ell)} = L_\ell \dots L_1 A$ with*

$$L_k = \begin{pmatrix} 1 & 0 & \cdots & \cdots & \cdots & \cdots & \cdots & 0 \\ 0 & \ddots & \ddots & & & & & \vdots \\ \vdots & \ddots & \ddots & \ddots & & & & \vdots \\ \vdots & & 0 & 1 & \ddots & & & \vdots \\ \vdots & & \vdots & -l_{k+1} & l_k & \ddots & & \vdots \\ \vdots & & \vdots & \vdots & 0 & \ddots & \ddots & \vdots \\ \vdots & & \vdots & & \vdots & \ddots & \ddots & 0 \\ 0 & \cdots & 0 & -l_c & 0 & \cdots & 0 & l_k \end{pmatrix}$$

$$\text{with } l_k = \frac{a_{k,k}^{(k-1)}}{a_{k-1,k-1}^{(k-2)}} \text{ and } l_j = \frac{a_{j,k}^{(k-1)}}{a_{k-1,k-1}^{(k-2)}} \text{ for } j = k + 1, \dots, c.$$

2. If A is furthermore symmetric, then the matrix $\tilde{A}^{(\ell)} = L^{(\ell)} A L^{(\ell)t}$, with $L^{(\ell)} = L_\ell \dots L_1$, is also symmetric. This matrix $\tilde{A}^{(\ell)}$ is given by

$$\tilde{A}^{(\ell)} = \begin{pmatrix} \tilde{a}_{11}^{(0)} & 0 & \cdots & \cdots & \cdots & 0 \\ 0 & \ddots & & & & \vdots \\ \vdots & & \tilde{a}_{\ell,\ell}^{(\ell-1)} & 0 & \cdots & 0 \\ & & 0 & \tilde{a}_{\ell+1,\ell+1}^{(\ell)} & \cdots & \tilde{a}_{\ell+1,c}^{(\ell)} \\ \vdots & \vdots & \vdots & \vdots & \vdots & \vdots \\ 0 & 0 & \tilde{a}_{c,\ell+1}^{(\ell)} & \cdots & \tilde{a}_{c,c}^{(\ell)} \end{pmatrix}, \quad (4.1)$$

with $\tilde{a}_{i,j}^{(k)} = a_{i,j}^{(k)} a_{k,k}^{(k-1)}$.

3. If $R \subset \mathbb{R}$ and A is furthermore positive semidefinite, then

- $a_{k,k}^{(k-1)} \neq 0$ for all $k = 1, \dots, \ell$ implies $a_{k,k}^{(k-1)} > 0$ for all $k = 1, \dots, \ell$.
- $a_{\ell+1,\ell+1}^{(\ell)}$ is either positive or zero. In this last case, $a_{\ell+1,\ell+j}^{(\ell)} = 0$ for all $1 \leq j \leq c - \ell$.

Proof. 1. The first observation is the basis of Bareiss's algorithm [4, 5, 30].

2. The second observation was presented in [41, 73].

3. Let A_J be the $(\ell+2) \times (\ell+2)$ leading principal submatrix of A . If we apply the adequately truncated $L^{(\ell)}$ to A_J , we obtain the $(\ell+2) \times (\ell+2)$ leading principal submatrix of $A^{(\ell)}$. We have then

$$\left(a_{\ell,\ell}^{(\ell-1)}\right)^2 \left(\prod_{k=1}^{\ell-1} a_{k,k}^{(k-1)}\right) \det(A_J) = \left(\prod_{k=1}^{\ell} a_{k,k}^{(k-1)}\right) \left(a_{\ell+1,\ell+1}^{(\ell)} a_{\ell+2,\ell+2}^{(\ell)} - \left(a_{\ell+1,\ell+2}^{(\ell)}\right)^2\right).$$

If $a_{k,k}^{(k-1)} > 0$ for all $1 \leq k \leq \ell$ and $a_{\ell+1,\ell+1}^{(\ell)} = 0$ while $a_{\ell+1,\ell+2}^{(\ell)} \neq 0$ then $\det A_J < 0$. According to Theorem 4.1 this contradicts A being positive semidefinite.

Notice that we used the fact that

$$\det L_k = \left(\frac{a_{k,k}^{(k-1)}}{a_{k-1,k-1}^{(k-2)}}\right)^{c-k} \quad \text{so that} \quad \det L^{(\ell)} = \left(a_{\ell,\ell}^{(\ell-1)}\right)^{c-\ell} \prod_{k=1}^{\ell-1} a_{k,k}^{(k-1)}$$

and replaced c by $\ell+2$ to reflect the truncation.

The same argument, changing A_J to be another principal matrix, shows that for A to be positive semidefinite when $a_{\ell+1,\ell+1}^{(\ell)} = 0$, it is required that $a_{\ell+1,\ell+j}^{(\ell)} = 0$ for all $2 \leq j \leq c - \ell$. □

If we consider a symmetric $c \times c$ matrix A with entries in $R \subset \mathbb{R}$ that is positive definite then, according to Theorem 4.1, $a_{\ell,\ell}^{(\ell-1)} > 0$ for all $1 \leq \ell \leq c$. We can thus proceed with elimination steps without any pivoting. After $c - 1$ such steps we have

$$\tilde{A}^{(c-1)} = \begin{pmatrix} a_{0,0}^{(-1)} a_{1,1}^{(0)} & 0 & \cdots & 0 \\ 0 & a_{1,1}^{(0)} a_{2,2}^{(1)} & \ddots & \vdots \\ \vdots & \ddots & \ddots & 0 \\ 0 & \cdots & 0 & a_{c-1,c-1}^{(c-2)} a_{c,c}^{(c-1)} \end{pmatrix}.$$

In general though one might encounter $a_{k,k}^{(k-1)}$ that is zero. One then has to introduce a pivoting strategy. This one differs wether one is interested in the triangularization or the diagonalization. See [5, 30] and [41] respectively.

We are here more concerned with positive semidefinite matrices. The third observation in Theorem 4.3 allows us to proceed without pivoting. This result can be restated as follows for an algorithmic point view.

Proposition 4.4. *Let A be a symmetric $c \times c$ matrix with entries in an integral domain $R \subset \mathbb{R}$. Assume that $a_{k,k}^{(k-1)} > 0$ for $1 \leq k < \ell$. If $a_{\ell,\ell}^{(\ell-1)} = 0$ then*

A is positive semidefinite of rank $r \geq \ell - 1$ if and only if $a_{\ell,\ell+j}^{(\ell-1)} = 0$ for all $1 \leq j \leq c - \ell$ and the principal submatrix $A_{\hat{\ell}}$ obtained from A by removing the ℓ -th row and column is positive semidefinite of rank r .

Notice that for $k \leq \ell$ we have $(A_{\hat{\ell}})^{(k)} = (A^{(k)})_{\hat{\ell}}$. So we can start the triangularization process and when we encounter a pivot that is zero, we remove (ignore) that row and column and continue on. The entries of the successive matrices we encounter are thus determinants of a principal submatrix of A , whose size is the rank of A .

We give a recursive presentation of the algorithm that will be completed with a branching process in next section. The algorithm is initially called with A , $P = [1]$ and $E = []$. For the algorithmic description we will use the following notation. For a matrix $A = (a_{ij})_{1 \leq i,j \leq c}$ with entries in R and $p \in R$, we define the first elimination matrix with the last non-zero pivot p as

$$L(A, p) = \begin{pmatrix} 1 & 0 & \dots & \dots & 0 \\ -\frac{a_{2,1}}{p} & \frac{a_{1,1}}{p} & \ddots & & \vdots \\ \vdots & 0 & \ddots & \ddots & \vdots \\ \vdots & \vdots & \ddots & \ddots & 0 \\ -\frac{a_{c,1}}{p} & 0 & \dots & 0 & \frac{a_{1,1}}{p} \end{pmatrix}$$

Algorithm 4.5. Fraction-free diagonalization

- Input : $\triangleright A$ a symmetric $c \times c$ matrix with entries in $R \subset \mathbb{R}$ that is positive semidefinite.
 $\triangleright P$ a list of positive elements of R , P stands for *pivots* or *positive*.
 $\triangleright E$ a list of elimination matrices with entries in the quotient field of R .
- Output: $\triangleright P$ a list of positive elements of R with $\text{Card}(P) = \text{rank } A + 1$.
 $\triangleright E$ a list of elimination matrices with entries in the quotient field of R such that the product L of the elements in E satisfies $L A L^t$ is a diagonal matrix whose non-zero entries are the product of two consecutive elements of P .

If $c = 0$ then **return** P, E ; Otherwise:

if $a_{11} > 0$ then

- Let p be the last element of P .
- Append $a_{1,1}$ to P .

- Append $L(A, p)$ to E .
- Let A be now the submatrix of $L(A, p)$ obtained by removing the first row and first column.

elif $a_{1,1} = 0$ (and therefore $a_{1,j} = 0$ for any $2 \leq j \leq c$) *then*

- Let A be now the submatrix of A obtained by removing the first row and first column.

Make a recursive call with A , P and E as obtained above.

4.3 Diagonalization over the locus positivity

Consider now the integral domain R as the polynomial ring $\mathbb{K}[h] = \mathbb{K}[h_1, \dots, h_t]$, where $\mathbb{K} \subset \mathbb{R}$ is a field extension of \mathbb{Q} . With the criterion presented in previous section, we can write a fraction-free algorithm that provides a diagonalization of A over its locus of positivity.

Let us introduce the *specialization* $\phi : \mathbb{K}[h] \rightarrow \mathbb{R}$, which is a \mathbb{K} -morphism. A typical example is given by

$$\phi_{\tilde{h}} : \mathbb{K}[h] \rightarrow \mathbb{R}, p \mapsto p(\tilde{h})$$

with $\tilde{h} = (\tilde{h}_1, \dots, \tilde{h}_t)$ a point in \mathbb{R}^t . Given a matrix $A = (a_{ij})_{1 \leq i, j \leq c}$ with $a_{ij} \in \mathbb{K}[h]$, we denote by $\phi(A)$ the matrix obtained by applying ϕ to the coefficients of A , that is

$$\phi(A) = (\phi(a_{ij}))_{1 \leq i, j \leq c} = (\bar{a}_{ij})_{1 \leq i, j \leq c}.$$

Likewise

$$\bar{a}_{ij}^{(\ell)} = \det \begin{pmatrix} \bar{a}_{1,1} & \cdots & \bar{a}_{1,\ell} & \bar{a}_{1,j} \\ \vdots & & \vdots & \vdots \\ \bar{a}_{\ell,1} & \cdots & \bar{a}_{\ell,\ell} & \bar{a}_{\ell,j} \\ \bar{a}_{i,1} & \cdots & \bar{a}_{i,\ell} & \bar{a}_{i,j} \end{pmatrix} = \phi \left(a_{ij}^{(\ell)} \right) \quad \forall 1 \leq \ell \leq c-1, \forall \ell < i, j \leq c.$$

We give a recursive description of the algorithm. It is initialized with the full symmetric matrix A , $P = [1]$, $Z = \emptyset$ and E the empty list. We will use the following notation. For a matrix $A = (a_{ij})_{1 \leq i, j \leq c}$ with entries in R and $p \in R$, we define the first elimination matrix with the last non-zero pivot p as

$$L(A, p) = \begin{pmatrix} 1 & 0 & \cdots & \cdots & 0 \\ -\frac{a_{2,1}}{p} & \frac{a_{1,1}}{p} & \ddots & & \vdots \\ \vdots & 0 & \ddots & \ddots & \vdots \\ \vdots & \vdots & \ddots & \ddots & 0 \\ -\frac{a_{c,1}}{p} & 0 & \cdots & 0 & \frac{a_{1,1}}{p} \end{pmatrix}$$

Algorithm 4.6. Diagonalization & Positivity

- Input :
- ▷ A $c \times c$ symmetric matrix $A = (a_{ij})_{1 \leq i, j \leq c}$ with entries in $\mathbb{K}[h]$.
 - ▷ P a list of polynomials in $\mathbb{K}[h]$, P stands for *pivots* or *positive*.
 - ▷ Z a set of polynomials in $\mathbb{K}[h]$, Z stands for *zero*.
 - ▷ E a list of elimination matrices.
- Output:
- ▷ A set \mathcal{S} of triplets $[P, Z, E]$, where
 - P is a list of polynomials in $\mathbb{K}[h]$,
 - Z is a set of polynomials in $\mathbb{K}[h]$,
 - E is a list of elimination matrices in $\mathbb{K}(h)$
whose denominators are power products of elements in P .

The set \mathcal{S} satisfies the following property: For a specialization $\phi : \mathbb{K}[h] \rightarrow \mathbb{R}$, $\phi(A)$ is positive semidefinite if and only if there is a triplet $[P, Z, E]$ in \mathcal{S} such that

$$\phi(p) > 0 \forall p \in P \text{ and } \phi(q) = 0 \forall q \in Z.$$

In this case $\text{Card}(P) - 1$ is the rank of $\phi(A)$ and, letting L be the product of the elements of E , $\phi(LAL^t)$ is a diagonal matrix whose non zero entries are the product of two consecutive elements in $\phi(P) = \{\phi(p), p \in P\}$.

*If $c = 0$ then **return** $[P, Z, E]$; Otherwise:*

\mathcal{S}_1 and \mathcal{S}_2 initialized to \emptyset .

If $a_{11} \notin \mathbb{K}$ or $a_{11} > 0$ then

- Let p be the last element of P .
- Let A_1 be the submatrix of $L(A, p)A$ obtained by removing the first row and first column.
- Append a_{11} to P to give P_1 .
- Append $L(A, p)$ to E to give E_1 .
- $\mathcal{S}_\infty :=$ Diagonalization & Positivity (A_1, P_1, Z, E_1).

If $a_{11} \notin \mathbb{K}$ or $a_{11} = 0$ then

- $Z_2 := \{a_{1,j} \mid 1 \leq j \leq n\} \cup Z$.
- A_2 is obtained from A by removing the first row and first column.
- $\mathcal{S}_\infty :=$ Diagonalization & Positivity (A_2, P, Z_2, E).

return $\mathcal{S} := \mathcal{S}_1 \cup \mathcal{S}_2$.

The elements in P and Z are principal minors of A of size up to order $\text{Card}(P) - 1$. This determines their degrees in terms of the degrees of the entries of A . Furthermore, the output set \mathcal{S} can have as many as 2^c triplets. One can of course lower this number if we can dismiss certain branches by checking if the semialgebraic set defined by a pair (P, Z) is consistent. Though this is algorithmic [6], it is no light task. One cannot expect Algorithm 4.6 to run easily on large matrices A with polynomial entries.

4.4 Diagonalization for determining the existence of cubatures

Taking into account the specificity of the cubature problem, we revisit the procedure in the previous section. There are less cases to be distinguished so that the size of the output is smaller.

Let A be a $c \times c$ symmetric matrix whose entries are polynomials of degree at most 1 in the parameters h_1, \dots, h_t . The cubature problem comes with additional input indices $c' \leq r \leq c'' \leq c$. Let A' (resp. A'') be the $c' \times c'$ (resp. $c'' \times c''$) leading principal submatrix of A . They satisfy:

- The submatrix A' has entries in $\mathbb{K} \subset \mathbb{R}$ a field extension of \mathbb{Q} and is positive definite.
- The submatrix A'' , under the conditions on h_1, \dots, h_t we are looking for, is positive semidefinite and has the same rank r as the matrix A .

To determine those conditions, Algorithm 4.6 can be applied. The size of its output is reduced thanks to the information on A_{J_1} and A_{J_2} : we get less than 2^c triplets.

- Since A' is positive definite, the algorithm runs without splitting as long as the matrix is of size bigger than $c - c'$. The first c' pivots are added to P .
- Since A'' is require to have the same rank as A , the algorithm is stopped when the matrix is of size $c - c''$. All its entries are added to Z .
- Not all the branches created by the algorithm are interesting: only the ones such that $\text{Card } P = r + 1$ (as we included 1 as first pivot in P). There are then $\binom{c'' - c'}{r - c'}$ interesting branches to be studied.

Algorithm 4.7. Diagonalization & Positivity with Rank Constraints

- Input :
- ▷ Integers $c' \leq r \leq c'' \leq c$.
 - ▷ A $c \times c$ symmetric matrix A with entries in $\mathbb{K}[h]_{\leq 1}$, whose $c' \times c'$ leading principal submatrix is positive definite with entries in \mathbb{K} .
 - ▷ P a list of polynomials in $\mathbb{K}[h]$.
 - ▷ Z a set of polynomials in $\mathbb{K}[h]$.
 - ▷ E a list of elimination matrices.
- Output: ▷ A set \mathcal{S} of $\binom{c'' - c'}{r - c'}$ triplets $[P, Z, E]$, where
- P is a list of polynomials in $\mathbb{K}[h]$ with $\text{Card } P = r + 1$,
 - Z is a set of polynomials in $\mathbb{K}[h]$,
 - E is a list of elimination matrices in $\mathbb{K}(h)$ whose denominators are power products of elements in P .

The set \mathcal{S} satisfies the following property: For a specialization $\phi : \mathbb{K}[h] \rightarrow \mathbb{R}$, $\phi(A)$ is positive semidefinite if and only if there is a triplet $[P, Z, E]$ such that

$$\phi(p) > 0 \quad \forall p \in P \text{ and } \phi(q) = 0 \quad \forall q \in Z.$$

In this case, the rank of $\phi(A)$ is r and, letting L be the product of the elements of E , $\phi(LAL^t)$ is a diagonal matrix whose non zero entries are the product of two consecutive elements in $\phi(P) = \{\phi(p), p \in P\}$.

Remark 4.8. If the symmetric matrix A is the matrix of a symmetric bilinear form in a certain basis B as in the case of the search for cubatures, then the product L of all elements of E provides the appropriate change of basis described in Theorem 4.3.2 with $\ell = c - 1$ that diagonalizes A .

In addition, under the conditions on h_1, \dots, h_t given by P and Z , this diagonal matrix has exactly r non zero entries. They correspond to evaluations of the symmetric bilinear form at squares of r elements of the basis B . The construction of a basis such that the matrix of the symmetric bilinear form is invertible can then be done without E . It is sufficient to select the appropriate r elements in the elements of B .

5 Moment matrix approach to computing cubatures

The algorithms in this section provide the computational solution for the moment matrix approach to cubature. While the authors in [25] lay the foundations of this approach with theoretical results and examples, this section completes them with an algorithmic treatment, which is later enriched for symmetric cubatures.

The proposed solution is divided in three parts. With the help of the last algorithm in the previous section, we first provide a way to determine the existence for a given measure of cubatures of a given degree with positive weights. This issue indeed boils down to find the values of parameters such that a structured symmetric matrix is positive semidefinite of rank r , the number of nodes. We then show how to guarantee that the nodes lie on the support of the measure. We introduce there an algorithm that extends to any polynomial space a linear form that respects the flat extension and positive semidefiniteness assumptions. Once the existence of a cubature is secured, the third algorithm computes the weights and the coordinates of the nodes by solving generalized eigenvalue problems. Only this last stage resorts to floating point arithmetic.

As an example, we choose the known cubature of degree 5 with 7 nodes for the regular hexagon H_2 in [78]. It can be solved with the present approach, but shows some limitations in the direct application of this algorithm. This computationally intensive example turns rather gentle when taking advantage of symmetry in Section 9.4.

The moment matrix approach to cubature we present is based on Curto-Fialkow's Flat Extension theorem as in [25] and on Hankel operators as in [1]. The search for minimal cubatures is reformulated in a (numerical) SemiDefinite Programming problem in [1]. It consists in minimizing the nuclear norm of Hankel operators associated with possible extensions of the linear form obtained from the known moments. While SDP solver provides a solution, we are interested in finding cubatures that satisfy certain assumptions. In addition, in some cases, we are able to provide the exact coordinates of the nodes and the exact weights.

Curto-Fialkow's Flat Extension theorem has also been used in the context of Gaussian cubatures [50]. Their existence is determined by an overdetermined linear system. This is an alternative criterion to the ones known from the theory of multivariate orthogonal polynomials [20, Chapter 3.6] that consist in checking either if the n multiplication operators $\mathcal{M}_{x_1}, \dots, \mathcal{M}_{x_n}$ by x_1, \dots, x_n in $\mathbb{R}[x]/I_\Lambda$ have exactly $\dim \mathbb{R}[x]_{\leq \lfloor \frac{d}{2} \rfloor}$ joint eigenvalues, or if they commute pairwise. Notice that the matrices of the multiplication operators in an orthonormal basis are the (multivariate) Jacobi matrices constructed thanks to the three term relation [20, Chapter 3.2]. This link is mentioned in [68], where the author studied cubatures using an operator theory approach.

5.1 Existence conditions for a cubature

Let μ be a positive Borel measure with compact support in \mathbb{R}^n . Given a degree d , we want to determine if there exists a cubature Λ of degree d with positive weights. The moments of order less than or equal to d are thus part of the input. They can be computed exactly following [3, 76] when μ is the characteristic function of a polytope. The expected number of nodes r is also fixed: a starting point is given by the known lower bounds (see Section 2).

Algorithm 5.1. Existence of a cubature

- Input : ▷ The degree d of the expected cubature Λ .
 ▷ The moments of order less than or equal to d for the measure μ .
 ▷ A number of nodes r bigger than the lower bound $\dim \mathbb{R}[x]_{\leq \lfloor \frac{d}{2} \rfloor}$.
 Output : ▷ A system of equations and inequations that determines the existence for μ
 of a cubature Λ of degree d with positive weights.

1. Choose a degree δ such that $\dim \mathbb{R}[x]_{\leq \delta-1} \geq r$.
2. Take the monomial basis $B^{(\delta)} = \{b_1, \dots, b_c\}$ of $\mathbb{R}[x]_{\leq \delta}$ following the graded reverse lexicographic order.
3. Construct the moment matrix $H_1^{B^{(\delta)}} = (\Lambda(b_i b_j))_{1 \leq i, j \leq c}$.

This is the matrix of the Hankel operator $\mathcal{H}^{(\delta)}$ associated with the restriction $\Lambda^{(\delta)}$ of Λ to $\mathbb{R}[x]_{\leq 2\delta}$. Every coefficient $\Lambda(b_i b_j)$ is:

- *either the value of the moment $\int b_i(x) b_j(x) d\mu(x) \in \mathbb{K} \subset \mathbb{R}$ if $\deg(b_i b_j) \leq d$,*
- *or an unknown, denoted by h_ℓ , if the monomial $b_i b_j$ has degree bigger than d .*

There is one distinct parameter h_ℓ per monomial of degree between $d + 1$ and 2δ . The number t of distinct parameters is then

$$t = \dim \mathbb{R}[x]_{\leq 2\delta} - \dim \mathbb{R}[x]_{\leq d}. \quad (5.1)$$

The $c' \times c'$ leading principal submatrix of $H_1^{B^{(\delta)}}$, with $c' = \dim \mathbb{R}[x]_{\leq \lfloor \frac{d}{2} \rfloor}$, has thus entries in \mathbb{K} and is positive definite.

4. Find conditions on the parameters h_1, \dots, h_t , using Algorithm 4.7 [Diagonalization & Positivity with Rank Constraints] on the matrix $H_1^{B^{(\delta)}}$, such that the linear form $\Lambda^{(\delta)}$ is a flat extension of the linear form $\Lambda^{(\delta-1)}$ and such that the Hankel operator $\mathcal{H}^{(\delta)}$ is positive semidefinite with rank r .

Following Corollary 3.15, those properties are sufficient to prove the existence for the measure μ of a cubature of degree d with r nodes and with positive weights.

The matrix $H_1^{B^{(\delta)}}$, under the conditions on the parameters h_1, \dots, h_t , satisfies then:

- *Its $c'' \times c''$ leading principal submatrix, with $c'' = \dim \mathbb{R}[x]_{\leq \delta-1}$, has the same rank r as the whole matrix $H_1^{B^{(\delta)}}$.*
- *$H_1^{B^{(\delta)}}$ is positive semidefinite.*

Thus, Algorithm 4.7 can be used to determine those conditions: each triplet $[P, Z, E]$ provides a system of equations (from Z) and inequations (from P) that determines the existence of a cubature.

Algorithm 5.1 gives thus a system of equations and inequations that determines the existence for μ of a cubature of degree d with positive weights. There is then no guarantee that the nodes lie on the support of μ . This property is examined in the next section.

Since this generally requires the determination of additional parameters h_ℓ , we suggest to skip it in practice. In general, the fact that the cubature is an inside cubature can then be checked after the computation of the nodes.

5.2 Existence of an inside cubature

In the following, we assume that the existence of a cubature Λ has been shown, that is we know conditions on parameters h_1, \dots, h_t such that the assumptions of Corollary 3.15 are satisfied: flat extension and positive semidefiniteness.

To guarantee that the nodes of the sought cubature Λ lie on $\text{supp } \mu$, we shall assume that $\text{supp } \mu$ is semialgebraic

$$\text{supp } \mu = \{x \in \mathbb{R}^n \mid g_1(x) \geq 0, \dots, g_s(x) \geq 0\}$$

with $g_k \in \mathbb{R}[x]$ for all $k = 1, \dots, s$. According to Proposition 3.16, it is then sufficient to show that the Hankel operators \mathcal{H}_{g_k} are positive semidefinite for all $k = 1, \dots, s$.

Let $\kappa \in \mathbb{N}$ be such that $\kappa \geq 1$ and $2\kappa \geq \deg g_k$ for all $k = 1, \dots, s$. Consider the matrices $H_{g_k}^{B(\delta-1)} = (\Lambda(g_k b_i b_j))_{1 \leq i, j \leq r_{\delta-1}}$, where $B(\delta-1) = \{b_1, \dots, b_\gamma\}$ is a basis of $\mathbb{R}[x]_{\leq \delta-1}$. Its coefficients are numbers in \mathbb{K} , or polynomials in the parameters h_1, \dots, h_t , or unknowns¹. Those unknown coefficients are uniquely determined by the flat extension assumption. Theorem 3.14 implies indeed that the linear form $\Lambda^{(\delta+\kappa-1)}$ on $\mathbb{R}[x]_{\leq 2\delta+2\kappa-2}$ is uniquely determined by the conditions on h_1, \dots, h_t , or equivalently by a triplet $[P, Z, E]$ using the notations of Algorithm 4.7.

Algorithm 5.2. Unique Extension

- Input :
- ▷ Integers d, δ and κ such that:
 - The values $\Lambda(p)$ are known if $\deg p \leq d$.
 - The coefficients of the matrix $H_1^{B(\delta)}$ of the Hankel operator associated with Λ in a basis $B(\delta)$ of $\mathbb{R}[x]_{\leq \delta}$ are either numbers in \mathbb{K} , or polynomials in h_1, \dots, h_t .
 - A basis $B^{(\delta+\kappa-1)}$ of $\mathbb{R}[x]_{\leq \delta+\kappa-1}$ is taken such that $B(\delta) \subset B^{(\delta+\kappa-1)}$.
 - ▷ A system of equations and inequations in the parameters h_1, \dots, h_t such that the assumptions of Corollary 3.15 are satisfied.
- Output :
- ▷ The matrix $H_1^{B^{(\delta+\kappa-1)}}$ whose entries are either numbers in \mathbb{K} , or polynomials in parameters $h_1, \dots, h_t, h_{t+1}, \dots, h_\tau$, where h_{t+1}, \dots, h_τ are additional parameters defined by $h_\ell = \Lambda(p_\ell)$ with $2\delta \leq \deg p_\ell \leq 2\delta + 2\kappa - 2$.
 - ▷ A system of equations and inequations on h_1, \dots, h_τ such that $\Lambda^{(\delta+\kappa-1)}$ is the unique flat extension of $\Lambda^{(\delta)}$.

The main ingredient to determine the system in output of Algorithm 5.2 is Algorithm 4.7. There is however only one triplet $[P, Z, E]$. The choice of the unique branch is determined by the system of equations and inequations in the parameters h_1, \dots, h_t . Indeed, the principal submatrix of $H_1^{B^{(\delta+\kappa-1)}}$ that corresponds to $H_1^{B(\delta)}$ has the same rank as $H_1^{B^{(\delta+\kappa-1)}}$. Once this submatrix is treated, the remaining entries are then added to Z .

The entries of the matrices $H_{g_k}^{B(\delta-1)}$ are then either numbers in \mathbb{K} , or polynomials in h_1, \dots, h_τ . It remains to find conditions on h_1, \dots, h_τ such that those matrices are positive semidefinite. This can be done with the help of Algorithm 4.6 or the characteristic polynomial of the matrices $H_{g_k}^{B(\delta-1)}$ as presented in Section 4.1.

¹This last case appears if and only if there exists $k \in \{1, \dots, s\}$ such that $\deg g_k > 2$.

5.3 Computation of the weights and the coordinates of the nodes

Assume now that the existence of a cubature has been secured with a solution $(\hbar_1, \dots, \hbar_t)$ of the polynomial system of equations and inequations output by Algorithm 5.1. To simplify the notations, we do not consider here the additional step in Section 5.2. Algorithm 5.3 then computes the weights and the coordinates of the nodes of the associated cubature.

Algorithm 5.3. Weights and Nodes

Input : ▷ Input of Algorithm 5.1.
 ▷ The parameterized matrix $H_1^{B^{(\delta)}}$.
 ▷ A value \hbar_1, \dots, \hbar_t for each parameter h_1, \dots, h_t introduced in Algorithm 5.1.
 Output : ▷ The coordinates of the nodes ξ_1, \dots, ξ_r .
 ▷ The weights a_1, \dots, a_r .

1. Take polynomials b_1, \dots, b_r such that $B = \{[b_1], \dots, [b_r]\}$ is a basis of $\mathbb{R}[x]/I_\Lambda$.

Following Remark 4.8 and Theorem 3.6, the use of Algorithm 4.7 (Step 4 in Algorithm 5.1) gives a way to determine a basis B of $\mathbb{R}[x]/I_\Lambda$ by selecting the appropriate polynomials in the monomial basis $B^{(\delta)}$ of $\mathbb{R}[x]_{\leq \delta}$.

2. Compute the invertible matrix H_1^B of the linear operator \mathcal{H} associated with the sought cubature Λ in the basis B of $\mathbb{R}[x]/I_\Lambda$. Using the values \hbar_1, \dots, \hbar_t , this matrix has entries in \mathbb{K} .

Since the basis B of $\mathbb{R}[x]/I_\Lambda$ is obtained from polynomials in $B^{(\delta)}$, the matrix H_1^B is a principal submatrix of $H_1^{B^{(\delta)}}$ introduced in Step 3 of Algorithm 5.1.

The entries are either numbers in \mathbb{K} or parameters h_1, \dots, h_t . It is then sufficient to replace the parameters h_1, \dots, h_t by the values \hbar_1, \dots, \hbar_t .

3. Take a polynomial $p \in \mathbb{R}[x]_{\leq 1}$ that separates the generalized eigenvalues of (H_p^B, H_1^B) .

This means that the generalized eigenvalues, which are the values $p(\xi_1), \dots, p(\xi_r)$ following Corollary 3.9, are distinct.

4. Compute the matrix H_p^B .

Since $\deg p < 2$, the entries of H_p^B are completely determined by the moments of order less than or equal to d and the values \hbar_1, \dots, \hbar_t of the parameters h_1, \dots, h_t .

5. Compute the left eigenvectors of the matrix $M_p^B = (H_1^B)^{-1} H_p^B$ and deduce the coordinates of the nodes.

Following Theorem 3.4, each left eigenvector of M_p^B contains the evaluations of the elements of B at a node ξ_1, \dots, ξ_r (up to a scalar). Assuming that $[1], [x_1], \dots, [x_n]$ belong to B , the coordinates of the nodes ξ_1, \dots, ξ_r can be read in the matrix $W = (b_j(\xi_i))_{1 \leq i, j \leq r}$ of left eigenvectors (up to a normalization thanks to the presence of $[1]$ in B).

6. Solve the Vandermonde-like linear system (2.9) with $(p_1, \dots, p_r) = (b_1, \dots, b_r)$, that is

$$W^t \begin{pmatrix} a_1 \\ \vdots \\ a_r \end{pmatrix} = \begin{pmatrix} \Lambda(b_1) \\ \vdots \\ \Lambda(b_r) \end{pmatrix}.$$

The weights a_1, \dots, a_r are its unique solutions.

5.4 H_2 5 – 1 (Stroud, 1971): a first resolution

We are looking for a cubature of degree 5 with 7 nodes for the regular hexagon H_2 in the plane \mathbb{R}^2 . It is described in [78] under the name $H_2 : 5 - 1$.

Let H_2 be the regular hexagon whose vertices are given by $(\pm 1, 0), (\pm \frac{1}{2}, \pm \frac{\sqrt{3}}{2})$ (see Figure 2(a)). Its moments of order less than or equal to 5 are

$$\int_{H_2} 1 dx = \frac{3\sqrt{3}}{2}, \quad \int_{H_2} x_1^2 dx = \int_{H_2} x_2^2 dx = \frac{5\sqrt{3}}{16}$$

$$\int_{H_2} x_1^4 dx = \int_{H_2} x_2^4 dx = \frac{21\sqrt{3}}{160}, \quad \int_{H_2} x_1^2 x_2^2 dx = \frac{7\sqrt{3}}{160}$$

and zero otherwise.

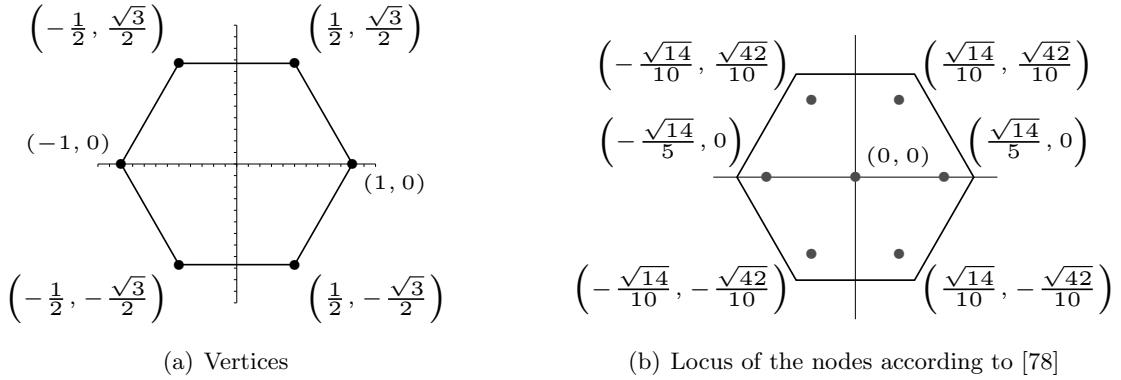

Figure 2: Regular hexagon H_2

Existence

Using Algorithm 5.1, we prove the existence of such a cubature. Due to the difficulty of the computation, we do not attempt to find all such cubatures.

1. Take $\delta = 4$.
2. The monomial basis $B^{(4)}$ of $\mathbb{R}[x]_{\leq 4}$ following the graded reverse lexicographic order is

$$B^{(4)} = \{1, x_1, x_2, x_1^2, x_1x_2, x_2^2, x_1^3, x_1^2x_2, x_1x_2^2, x_2^3, x_1^4, x_1^3x_2, x_1^2x_2^2, x_1x_2^3, x_2^4\}.$$

3. The parameterized moment matrix $H_1^{B^{(4)}}$, with $h_{ij} = \Lambda(x_1^i x_2^j)$, is

$$\left(\begin{array}{cccccc|cccc|cccc|cccc} \frac{3\sqrt{3}}{2} & 0 & 0 & \frac{5\sqrt{3}}{16} & 0 & \frac{5\sqrt{3}}{16} & 0 & 0 & 0 & 0 & \frac{21\sqrt{3}}{160} & 0 & \frac{7\sqrt{3}}{160} & 0 & \frac{21\sqrt{3}}{160} \\ 0 & \frac{5\sqrt{3}}{16} & 0 & 0 & 0 & 0 & \frac{21\sqrt{3}}{160} & 0 & \frac{7\sqrt{3}}{160} & 0 & 0 & 0 & 0 & 0 & 0 \\ 0 & 0 & \frac{5\sqrt{3}}{16} & 0 & 0 & 0 & 0 & \frac{7\sqrt{3}}{160} & 0 & \frac{21\sqrt{3}}{160} & 0 & 0 & 0 & 0 & 0 \\ \frac{5\sqrt{3}}{16} & 0 & 0 & \frac{21\sqrt{3}}{160} & 0 & \frac{7\sqrt{3}}{160} & 0 & 0 & 0 & 0 & h_{60} & h_{51} & h_{42} & h_{33} & h_{24} \\ 0 & 0 & 0 & 0 & \frac{7\sqrt{3}}{160} & 0 & 0 & 0 & 0 & 0 & h_{51} & h_{42} & h_{33} & h_{24} & h_{15} \\ \frac{5\sqrt{3}}{16} & 0 & 0 & \frac{7\sqrt{3}}{160} & 0 & \frac{21\sqrt{3}}{160} & 0 & 0 & 0 & 0 & h_{42} & h_{33} & h_{24} & h_{15} & h_{06} \\ \hline 0 & \frac{21\sqrt{3}}{160} & 0 & 0 & 0 & 0 & h_{60} & h_{51} & h_{42} & h_{33} & h_{70} & h_{61} & h_{52} & h_{43} & h_{34} \\ 0 & 0 & \frac{7\sqrt{3}}{160} & 0 & 0 & 0 & h_{51} & h_{42} & h_{33} & h_{24} & h_{61} & h_{52} & h_{43} & h_{34} & h_{25} \\ 0 & \frac{7\sqrt{3}}{160} & 0 & 0 & 0 & 0 & h_{42} & h_{33} & h_{24} & h_{15} & h_{52} & h_{43} & h_{34} & h_{25} & h_{16} \\ 0 & 0 & \frac{21\sqrt{3}}{160} & 0 & 0 & 0 & h_{33} & h_{24} & h_{15} & h_{06} & h_{43} & h_{34} & h_{25} & h_{16} & h_{07} \\ \hline \frac{21\sqrt{3}}{160} & 0 & 0 & h_{60} & h_{51} & h_{42} & h_{70} & h_{61} & h_{52} & h_{43} & h_{80} & h_{71} & h_{62} & h_{53} & h_{44} \\ 0 & 0 & 0 & h_{51} & h_{42} & h_{33} & h_{61} & h_{52} & h_{43} & h_{34} & h_{71} & h_{62} & h_{53} & h_{44} & h_{35} \\ \frac{7\sqrt{3}}{160} & 0 & 0 & h_{42} & h_{33} & h_{24} & h_{52} & h_{43} & h_{34} & h_{25} & h_{62} & h_{53} & h_{44} & h_{35} & h_{26} \\ 0 & 0 & 0 & h_{33} & h_{24} & h_{15} & h_{43} & h_{34} & h_{25} & h_{16} & h_{53} & h_{44} & h_{35} & h_{26} & h_{17} \\ \frac{21\sqrt{3}}{160} & 0 & 0 & h_{24} & h_{15} & h_{06} & h_{34} & h_{25} & h_{16} & h_{07} & h_{44} & h_{35} & h_{26} & h_{17} & h_{08} \end{array} \right)$$

There are $t = \dim \mathbb{R}[x]_{\leq 8} - \dim \mathbb{R}[x]_{\leq 4} = 24$ parameters. The 6×6 leading principal submatrix has entries in $\mathbb{Q}[\sqrt{3}]$ and is positive definite.

4. We look for conditions on those 24 parameters such that the assumptions of Corollary 3.15 are satisfied. We have here $c' = 6$, $r = 7$, $c'' = 10$ and $c = 15$ with the notations of Algorithm 4.7. There are then $\binom{4}{1} = 4$ triplets $[P, Z, E]$. We focus here on the one such that the 7×7 leading principal submatrix is positive definite.

The number of parameters is here too big for a reasonable use of Algorithm 4.7 on the whole matrix. We first use it for the $c'' \times c''$ leading principal submatrix. Solving the polynomial system obtained from Z and respecting the constraints from P , we get unique values for the involved parameters

$$h_{60} = \frac{539\sqrt{3}}{8000}, h_{51} = 0, h_{42} = \frac{49\sqrt{3}}{8000}, h_{33} = 0, h_{24} = \frac{147\sqrt{3}}{8000}, h_{15} = 0, h_{06} = \frac{441\sqrt{3}}{8000}.$$

Using Algorithm 4.7 on the whole $c \times c$ matrix with those values, we get the unique values for the remaining parameters

$$h_{80} = \frac{14749\sqrt{3}}{400000}, h_{62} = \frac{343\sqrt{3}}{400000}, h_{44} = \frac{1029\sqrt{3}}{400000}, h_{26} = \frac{3087\sqrt{3}}{400000}, h_{08} = \frac{9261\sqrt{3}}{400000},$$

$$h_{70} = h_{61} = h_{52} = h_{43} = h_{34} = h_{25} = h_{16} = h_{07} = h_{71} = h_{53} = h_{35} = h_{17} = 0.$$

Thus, we know that there exists for H_2 a cubature of degree 5 with 7 nodes and with positive weights. The fact that the nodes lie on H_2 is checked *a posteriori*. Following Remark 4.8, we also have that $B = \{[1], [x_1], [x_2], [x_1^2], [x_1x_2], [x_2^2], [x_1^3]\}$ is a basis of $\mathbb{R}[x]/I_\Lambda$.

Let us emphasize that there could be other cubatures of degree 5 with 7 nodes. Indeed, not all the triplets from the output of Algorithm 4.7 were examined.

Weights and nodes

With the values of the 24 parameters, we can compute the defining elements of the cubature with Algorithm 5.3.

1. Since the 7×7 leading principal submatrix of $H_1^{B^{(\delta)}}$ was chosen, a basis B of $\mathbb{R}[x]/I_\Lambda$ is obtained from the polynomials $1, x_1, x_2, x_1^2, x_1x_2, x_2^2, x_1^3$.
2. With the values of the 24 parameters,

$$H_1^B = \begin{pmatrix} \frac{3\sqrt{3}}{2} & 0 & 0 & \frac{5\sqrt{3}}{16} & 0 & \frac{5\sqrt{3}}{16} & 0 \\ 0 & \frac{5\sqrt{3}}{16} & 0 & 0 & 0 & 0 & \frac{21\sqrt{3}}{160} \\ 0 & 0 & \frac{5\sqrt{3}}{16} & 0 & 0 & 0 & 0 \\ \frac{5\sqrt{3}}{16} & 0 & 0 & \frac{21\sqrt{3}}{160} & 0 & \frac{7\sqrt{3}}{160} & 0 \\ 0 & 0 & 0 & 0 & \frac{7\sqrt{3}}{160} & 0 & 0 \\ \frac{5\sqrt{3}}{16} & 0 & 0 & \frac{7\sqrt{3}}{160} & 0 & \frac{21\sqrt{3}}{160} & 0 \\ 0 & \frac{21\sqrt{3}}{160} & 0 & 0 & 0 & 0 & \frac{539\sqrt{3}}{8000} \end{pmatrix}.$$

3. Taking $p = x_1 + 5x_2$, the generalized eigenvalues of (H_p^B, H_1^B) are all distinct.
4. With the values of the 24 parameters,

$$H_{x_1+5x_2}^B = \begin{pmatrix} 0 & \frac{5\sqrt{3}}{16} & \frac{25\sqrt{3}}{16} & 0 & 0 & 0 & \frac{21\sqrt{3}}{160} \\ \frac{5\sqrt{3}}{16} & 0 & 0 & \frac{21\sqrt{3}}{160} & \frac{7\sqrt{3}}{32} & \frac{7\sqrt{3}}{160} & 0 \\ \frac{25\sqrt{3}}{16} & 0 & 0 & \frac{7\sqrt{3}}{32} & \frac{7\sqrt{3}}{160} & \frac{21\sqrt{3}}{32} & 0 \\ 0 & \frac{21\sqrt{3}}{160} & \frac{7\sqrt{3}}{32} & 0 & 0 & 0 & \frac{539\sqrt{3}}{8000} \\ 0 & \frac{7\sqrt{3}}{32} & \frac{7\sqrt{3}}{160} & 0 & 0 & 0 & \frac{49\sqrt{3}}{1600} \\ 0 & \frac{7\sqrt{3}}{160} & \frac{21\sqrt{3}}{32} & 0 & 0 & 0 & \frac{49\sqrt{3}}{8000} \\ \frac{21\sqrt{3}}{160} & 0 & 0 & \frac{539\sqrt{3}}{8000} & \frac{49\sqrt{3}}{1600} & \frac{49\sqrt{3}}{8000} & 0 \end{pmatrix}.$$

5. The matrix W of left eigenvectors of the matrix $M_p^B = (H_1^B)^{-1} H_{x_1+5x_2}^B$ is

$$W = \left(\begin{array}{c|cc|ccc} 1 & \mathbf{0} & \mathbf{0} & 0 & 0 & 0 & 0 \\ 1 & \frac{\sqrt{14}}{5} & \mathbf{0} & \frac{14}{25} & 0 & 0 & \frac{14\sqrt{14}}{125} \\ 1 & -\frac{\sqrt{14}}{5} & \mathbf{0} & \frac{14}{25} & 0 & 0 & -\frac{14\sqrt{14}}{125} \\ 1 & -\frac{\sqrt{14}}{10} & \frac{\sqrt{42}}{10} & \frac{7}{50} & -\frac{\sqrt{47}}{50} & \frac{21}{50} & -\frac{7\sqrt{14}}{500} \\ 1 & \frac{\sqrt{14}}{10} & -\frac{\sqrt{42}}{10} & \frac{7}{50} & -\frac{\sqrt{47}}{50} & \frac{21}{50} & \frac{7\sqrt{14}}{500} \\ 1 & \frac{\sqrt{14}}{10} & \frac{\sqrt{42}}{10} & \frac{7}{50} & \frac{\sqrt{47}}{50} & \frac{21}{50} & \frac{7\sqrt{14}}{500} \\ 1 & -\frac{\sqrt{14}}{10} & -\frac{\sqrt{42}}{10} & \frac{7}{50} & \frac{\sqrt{47}}{50} & \frac{21}{50} & -\frac{7\sqrt{14}}{500} \end{array} \right).$$

Since $[x_1]$ and $[x_2]$ are the second and third classes of polynomials in B , the second and third columns of W are the coordinates of the nodes

$$\xi_1 = (0, 0), \quad \xi_2 = \left(\frac{\sqrt{14}}{5}, 0 \right), \quad \xi_3 = \left(-\frac{\sqrt{14}}{5}, 0 \right), \\ \xi_4 = \left(\frac{\sqrt{14}}{10}, \frac{\sqrt{42}}{10} \right), \xi_5 = \left(-\frac{\sqrt{14}}{10}, \frac{\sqrt{42}}{10} \right), \xi_6 = \left(-\frac{\sqrt{14}}{10}, -\frac{\sqrt{42}}{10} \right), \xi_7 = \left(\frac{\sqrt{14}}{10}, -\frac{\sqrt{42}}{10} \right).$$

6. Solving the Vandermonde-like linear system (2.9), we get the weights

$$(a_1, a_2, a_3, a_4, a_5, a_6, a_7) = \left(\frac{43\sqrt{3}}{112}, \frac{125\sqrt{3}}{672}, \frac{125\sqrt{3}}{672}, \frac{125\sqrt{3}}{672}, \frac{125\sqrt{3}}{672}, \frac{125\sqrt{3}}{672}, \frac{125\sqrt{3}}{672} \right).$$

We get thus the cubature in [78].

6 Symmetry adapted bases

The existence of symmetry in a problem leads to seek a way to reduce the computation by a factor depending on the size of the group describing the symmetry. In the context of the linear action of a finite group G on a \mathbb{C} -vector space, representation theory provides the tools to compute a basis of the vector space in which the matrices of a Hermitian form invariant under the group action is block diagonal. Such a basis is called *unitary symmetry adapted basis*. This terminology refers also to the fact that the representing matrices in this basis are unitary.

The block diagonalization is obtained thanks to two ingredients: the orthogonality relations for irreducible representations of a finite group and the possibility of using unitary irreducible representations.

In the case of a linear action on a \mathbb{R} -vector space, we detail how to construct an *orthogonal symmetry adapted basis* from unitary ones. The representing matrices in this basis are orthogonal. The most important property is that the matrices of a symmetric bilinear form invariant under the group action are block diagonal in an orthogonal symmetry adapted basis.

In both cases, there is additional structure on the blocks. The number of distinct blocks is bounded by the number of distinct *irreducible inequivalent representations* of the finite group. The size of each distinct block is the *multiplicity* of the irreducible inequivalent representation. The number of identical blocks per irreducible inequivalent representation is the *dimension* of the irreducible inequivalent representation.

The basic material on representation of finite groups is taken from [24, 75]. Symmetry adapted bases of \mathbb{C} -vector spaces are expanded on in [24]. They are used there to block diagonalize linear operators that commutes with a representation [24, The Fundamental Theorem], a consequence of Schur's lemma.

Symmetry adapted bases of \mathbb{R} -vector spaces were introduced in the context of optimization in [29] and then reused in [72]. In both cases, they are interested in block diagonalization of quadratic forms. For a direct application of [24, The Fundamental Theorem], they restrict their approach to symmetries given by orthogonal representations. Their main applications indeed require mostly permutation representations. This is a strong restriction that needs to be avoided for the present purpose. The symmetries we consider are given by those of polygons, or more generally polytopes. As such they are isometries and therefore given by orthogonal matrices. But the action we need to consider is the one induced on the polynomial ring. The matrices of this induced representation in a monomial basis are not orthogonal.

6.1 Linear representations and characters

Let G be a group, let V be a \mathbb{K} -vector space and let $GL(V)$ be the group of isomorphisms from V to itself. A *linear representation* of the group G on the space V is a group morphism from G to $GL(V)$. In other words, a linear representation \mathcal{V} assigns to each element g of the group G an isomorphism $\mathcal{V}(g)$ of the group $GL(V)$ such that

$$\mathcal{V}(g_1)\mathcal{V}(g_2) = \mathcal{V}(g_1g_2) \quad \forall g_1, g_2 \in G.$$

If V has finite dimension n , then upon introducing a basis B in V the isomorphism $\mathcal{V}(g)$ can be described by a non-singular $n \times n$ matrix. This *representing matrix* is denoted by $\mathcal{V}^B(g)$. V

is called the *representation space* and n is the *dimension* (or the *degree*) of the representation \mathcal{V} . Unless otherwise stated, we always deal with representations \mathcal{V} of finite dimension.

A linear representation \mathcal{V} of a group G on a space V is said to be *irreducible* provided there is no proper subspace W of V with the property that, for every $g \in G$, the isomorphism $\mathcal{V}(g)$ maps every vector of W into W . In this case, its representation space V is also called *irreducible*. A linear representation \mathcal{V} of a group G on a space V is said to be *completely reducible* if its representation space V is irreducible or if it decomposes into a finite number of irreducible subspaces W_1, \dots, W_M such that $V = W_1 \oplus \dots \oplus W_M$.

Two representations \mathcal{V} and \mathcal{W} of a group G respectively on the spaces V and W are said to be *equivalent* provided there exists a fixed isomorphism $\mathcal{T} : V \rightarrow W$ such that

$$\mathcal{W}(g) = \mathcal{T}\mathcal{V}(g)\mathcal{T}^{-1} \quad \forall g \in G.$$

Let \mathcal{V} be a completely reducible representation of a group G on a \mathbb{K} -vector space V . Let \mathcal{V}_j ($j = 1, \dots, \underline{N}$) be the irreducible inequivalent n_j -dimensional representations of G that appear in \mathcal{V} with multiplicities $c_j \geq 1$. The complete reduction of the representation \mathcal{V} is denoted by

$$\mathcal{V} = c_1\mathcal{V}_1 \oplus \dots \oplus c_{\underline{N}}\mathcal{V}_{\underline{N}}.$$

Accordingly, its representation space V decomposes into

$$V = V_1 \oplus \dots \oplus V_{\underline{N}}.$$

Each invariant subspace V_j is the direct sum of c_j irreducible subspaces and the restriction of \mathcal{V} to each one is equivalent to \mathcal{V}_j . The $(c_j n_j)$ -dimensional subspaces V_j of V are called *isotypic components*. Whereas the decomposition of V into irreducible components is not unique, its decomposition into a direct sum of isotypic components is unique [26, Proposition 1.8] and is called the *isotypic decomposition* of V .

We recall now important results concerning representations of a finite group on a \mathbb{C} -vector space. Results over \mathbb{R} can then be deduced from the ones over \mathbb{C} thanks to the constructions done in Section 6.4. The first one is given in [24, Chapter 1.11].

Theorem 6.1. 1. *Every representation of a finite group is completely reducible.*

2. *For every representation of a finite group, there is a basis such that the representing matrices in this basis are unitary.*

The second one can be deduced from the *orthogonality relations for irreducible representations* (see [24, Chapter 5.1] for the details of the computation).

Theorem 6.2. *A finite group G possesses a finite number of irreducible inequivalent representations.*

The representation space of any representation of a finite group G admits thus an isotypic decomposition. The latter can be determined in two steps:

1. Determination of all irreducible inequivalent representations $\mathcal{V}_1, \dots, \mathcal{V}_{\underline{N}}$ of the group G . They are known for some finite groups (see [24, Chapter 1.9] or [75, Chapter 5] for instance).

2. Computation of the multiplicities c_1, \dots, c_N , that is the number of times each irreducible inequivalent representation \mathcal{V}_j occurs in the representation \mathcal{V} .

This second task can be performed thanks to Theorem 6.3. Let \mathcal{V} be a representation of an arbitrary group G on a \mathbb{C} -vector space V . The complex-valued function

$$\chi : G \rightarrow \mathbb{C}, g \mapsto \text{Trace}(\mathcal{V}(g))$$

is called the *character* of the representation \mathcal{V} .

Theorem 6.3 ([24, Algorithm for computing multiplicities]). *Let \mathcal{V} (with character χ) be a representation of a finite group G of order $|G|$. Then, for every $j = 1, \dots, N$, the irreducible representation \mathcal{V}_j (with character χ_j) occurs in \mathcal{V} exactly c_j times, where*

$$c_j = \frac{1}{|G|} \sum_{g \in G} \overline{\chi_j(g)} \chi(g) \quad c_j \in \{0, 1, 2, \dots\}. \quad (6.1)$$

Notice that c_j can take here the value 0. This means that the irreducible inequivalent representation \mathcal{V}_j of the group G does not occur in the representation \mathcal{V} . A consequence of Theorem 6.3 is given by the next result. The latter underlines the importance of the character and shows how this function characterizes a representation.

Theorem 6.4 ([24, Theorem 5.11]). *Two representations of a finite group G are equivalent to each other if and only if their characters are identical.*

The character gives furthermore an *irreducibility criterion*:

Theorem 6.5 ([24, Theorem 5.10]). *A representation \mathcal{V} of a finite group G of order $|G|$ is irreducible if and only if the corresponding character χ satisfies*

$$\frac{1}{|G|} \sum_{g \in G} \overline{\chi(g)} \chi(g) = 1.$$

With the help of these results on the representations of a finite group on a \mathbb{C} -vector space, we can construct bases of their representation spaces that are of special interest.

6.2 Unitary symmetry adapted bases

Let \mathcal{V} be a representation of a finite group G on a \mathbb{C} -vector space V . Based on [75, Chapters 2.6 & 2.7], we present a way for computing a *unitary symmetry adapted basis* of every isotypic component V_j of the representation space V . This notion corresponds to the one of *symmetry adapted basis* given in [29] with the additional property that the matrices of the irreducible representations \mathcal{V}_j used for its computation are required to be unitary. In this section, we describe also the particular form of the matrices of the representation \mathcal{V} restricted to an isotypic component in a unitary symmetry adapted basis.

For every inequivalent irreducible n_j -dimensional representation \mathcal{V}_j ($j = 1, \dots, N$) of the group G with character χ_j , let p_j be the map defined on the representation space V by

$$p_j = \frac{n_j}{|G|} \sum_{g \in G} \overline{\chi_j(g)} \mathcal{V}(g).$$

The latter is the projection of V onto the isotypic component V_j associated with the isotypic decomposition of V [75, Theorem 8]. Thus, the isotypic decomposition of V can be determined thanks to the projections p_1, \dots, p_N .

Consider now representing matrices $\left(r_{\alpha\beta}^j(g)\right)_{1 \leq \alpha, \beta \leq n_j}$ for all irreducible n_j -dimensional representations \mathcal{V}_j of G . For every $(\alpha, \beta) \in \mathbb{N}^2$ such that $1 \leq \alpha, \beta \leq n_j$, let $p_{j,\alpha\beta} : V \rightarrow V$ be the linear map defined by

$$p_{j,\alpha\beta} = \frac{n_j}{|G|} \sum_{g \in G} r_{\beta\alpha}^j(g^{-1}) \mathcal{V}(g).$$

Proposition 6.6 ([75, Proposition 8]). *The linear maps $p_{j,\alpha\beta}$ satisfy the following properties:*

- (1) *For every $1 \leq \alpha \leq n_j$, the map $p_{j,\alpha\alpha}$ is a projection ; it is zero on the isotypic components V_k , $k \neq j$. Its image $V_{j,\alpha}$ is contained in the isotypic component V_j and V_j is the direct sum of the subspaces $V_{j,\alpha}$ for $1 \leq \alpha \leq n_j$, i.e.*

$$V_j = V_{j,1} \oplus \dots \oplus V_{j,n_j}. \quad (6.2)$$

We have $p_j = \sum_{\alpha=1}^{n_j} p_{j,\alpha\alpha}$.

- (2) *For every $(\alpha, \beta) \in \mathbb{N}^2$ such that $1 \leq \alpha, \beta \leq n_j$, the linear map $p_{j,\alpha\beta}$ is zero on the isotypic components V_k , $k \neq j$, as well as on the subspaces $V_{j,\gamma}$ for $\gamma \neq \beta$; it defines an isomorphism from $V_{j,\beta}$ to $V_{j,\alpha}$.*
- (3) *Let ζ_1 be a nonzero element of $V_{j,1}$ and let $\zeta_\alpha = p_{j,\alpha 1}(\zeta_1) \in V_{j,\alpha}$ for all $\alpha = 1, \dots, n_j$. For each $g \in G$, we have*

$$\mathcal{V}(g)(\zeta_\alpha) = \sum_{\beta=1}^{n_j} r_{\beta\alpha}^j(g) \zeta_\beta \quad \forall \alpha = 1, \dots, n_j.$$

With those properties of the linear maps $p_{j,\alpha\beta}$, a *symmetry adapted basis* of every isotypic component V_j can be computed, that is a basis of V_j compatible with the decomposition (6.2). If we consider unitary representing matrices $\left(r_{\alpha\beta}^j(g)\right)_{1 \leq \alpha, \beta \leq n_j}$, then the same process leads to *unitary symmetry adapted bases*. Since the coefficients of the matrices satisfy then $\overline{r_{\alpha\beta}^j(g)} = r_{\beta\alpha}^j(g^{-1})$, the linear maps $p_{j,\alpha\beta}$ are

$$p_{j,\alpha\beta} = \frac{n_j}{|G|} \sum_{g \in G} \overline{r_{\alpha\beta}^j(g)} \mathcal{V}(g).$$

Let \mathcal{V}_j be an irreducible n_j -dimensional representation of the group G that appears c_j times ($c_j \geq 1$) in the representation \mathcal{V} . Take $\{b_1, \dots, b_{c_j}\}$ a basis of the subspace $V_{j,1}$ defined as the image of V by the projection $p_{j,11}$. For every $2 \leq \alpha \leq n_j$, the linear map $p_{j,\alpha 1} : V_{j,1} \rightarrow V_{j,\alpha}$ is an isomorphism so that the set $\{p_{j,\alpha 1}(b_1), \dots, p_{j,\alpha 1}(b_{c_j})\}$ is a basis of $V_{j,\alpha}$. A unitary symmetry adapted basis of the isotypic component V_j is then given by

$$\widehat{B}_j = \{b_1, \dots, b_{c_j}, p_{j,21}(b_1), \dots, p_{j,21}(b_{c_j}), \dots, p_{j,n_j 1}(b_1), \dots, p_{j,n_j 1}(b_{c_j})\}.$$

In addition, we have

$$\begin{aligned}\mathcal{V}(g)(b_\gamma) &= r_{11}^j(g)b_\gamma + \sum_{\beta=2}^{n_j} r_{\beta 1}^j(g)p_{j,\beta 1}(b_\gamma) & \forall g \in G, \forall \gamma = 1, \dots, c_j, \\ \mathcal{V}(g)(p_{j,\alpha 1}(b_\gamma)) &= r_{1\alpha}^j(g)b_\gamma + \sum_{\beta=2}^{n_j} r_{\beta\alpha}^j(g)p_{j,\beta 1}(b_\gamma) & \forall g \in G, \forall \gamma = 1, \dots, c_j, \forall \alpha = 2, \dots, n_j.\end{aligned}$$

Thus, for every $g \in G$, the representing matrix of the representation \mathcal{V} restricted to the isotypic component V_j in the basis \widehat{B}_j is

$$\left(r_{\alpha\beta}^j(g) \right)_{1 \leq \alpha, \beta \leq n_j} \otimes I_{c_j} = \begin{pmatrix} r_{11}^j(g)I_{c_j} & r_{12}^j(g)I_{c_j} & \dots & r_{1n_j}^j(g)I_{c_j} \\ r_{21}^j(g)I_{c_j} & r_{22}^j(g)I_{c_j} & \dots & r_{2n_j}^j(g)I_{c_j} \\ \vdots & \vdots & \ddots & \vdots \\ r_{n_j 1}^j(g)I_{c_j} & r_{n_j 2}^j(g)I_{c_j} & \dots & r_{n_j n_j}^j(g)I_{c_j} \end{pmatrix},$$

where \otimes denotes the Kronecker product of two matrices and I_{c_j} the identity matrix of size $c_j \times c_j$.

In this construction, the choice of a basis of the subspace $V_{j,1}$ determines completely the bases \widehat{B}_j of the isotypic component V_j .

For all isotypic components V_j of the representation space V , unitary symmetry adapted bases \widehat{B}_j can be thus computed. The basis \widehat{B} , that consists of the union of the basis \widehat{B}_j , is also called *unitary symmetry adapted*. In this basis \widehat{B} , the matrix of the representation \mathcal{V} is block diagonal: the matrix of the representation \mathcal{V} restricted to an isotypic component V_j in the corresponding basis \widehat{B}_j is a block.

Remark 6.7. A basis \check{B}_j , which is compatible with a decomposition of the isotypic component V_j into c_j irreducible subspaces of dimension n_j , is then given by

$$\check{B}_j = \{b_1, p_{j,21}(b_1), \dots, p_{j,n_j 1}(b_1), \dots, b_{c_j}, p_{j,21}(b_{c_j}), \dots, p_{j,n_j 1}(b_{c_j})\}.$$

The matrix of the representation \mathcal{V} restricted to V_j in the basis \check{B}_j is

$$I_{c_j} \otimes \left(r_{\alpha\beta}^j(g) \right)_{1 \leq \alpha, \beta \leq n_j} = \begin{pmatrix} \left(r_{\alpha\beta}^j(g) \right)_{1 \leq \alpha, \beta \leq n_j} & 0_{n_j} & \dots & 0_{n_j} \\ 0_{n_j} & \left(r_{\alpha\beta}^j(g) \right)_{1 \leq \alpha, \beta \leq n_j} & \ddots & \vdots \\ \vdots & \ddots & \ddots & 0_{n_j} \\ 0_{n_j} & \dots & 0_{n_j} & \left(r_{\alpha\beta}^j(g) \right)_{1 \leq \alpha, \beta \leq n_j} \end{pmatrix},$$

where 0_{n_j} is the $n_j \times n_j$ zero matrix.

6.3 Invariant Hermitian forms

The bases constructed in Section 6.2 give us appropriate bases for studying a Hermitian form invariant under a representation of a finite group. We show that its matrix in these particular bases has a block diagonal structure : each block corresponds to the restriction of the Hermitian

form to an isotypic component. Using unitary symmetry adapted bases for all isotypic components, the corresponding submatrices have an additional block diagonal structure explained in Proposition 6.8.

Let \mathcal{V} be a representation of a finite group G on a n -dimensional \mathbb{C} -vector space V . A map $\phi : V \times V \rightarrow \mathbb{C}$ is said to be a G -invariant Hermitian form if it satisfies

$$\begin{aligned} \phi(\lambda u + v, w) &= \lambda\phi(u, w) + \phi(v, w) & \forall \lambda \in \mathbb{C}, \forall u, v, w \in V, \\ \phi(u, \lambda v + w) &= \bar{\lambda}\phi(u, v) + \phi(u, w) & \forall \lambda \in \mathbb{C}, \forall u, v, w \in V, \\ \phi(u, v) &= \overline{\phi(v, u)} & \forall u, v \in V \\ \text{and } \phi(u, v) &= \phi(\mathcal{V}(g)(u), \mathcal{V}(g)(v)) & \forall g \in G, \forall u, v \in V. \end{aligned}$$

The matrix $\phi^B = (\phi(b_i, b_j))_{1 \leq i, j \leq n}$ of the Hermitian form ϕ in a given basis $B = \{b_1, \dots, b_n\}$ is Hermitian, that is it satisfies $\phi^B = \overline{\phi^B}^t$.

Proposition 6.8. *Let \mathcal{V} be a representation of a finite group G on a \mathbb{C} -vector space V and let $\phi : V \times V \rightarrow \mathbb{C}$ be a G -invariant Hermitian form. Consider $V_1, \dots, V_{\underline{N}}$ the isotypic components of V . Then*

$$\phi(u, v) = 0 \quad \forall (u, v) \in V_i \times V_j \text{ with } i \neq j.$$

Hence the matrix $\phi^{\widehat{B}}$ of ϕ in any basis $\widehat{B} = \widehat{B}_1 \cup \dots \cup \widehat{B}_{\underline{N}}$ that respects the isotypic decomposition of V is block diagonal.

Assume furthermore that for every isotypic component V_j associated with an n_j -dimensional irreducible representation \mathcal{V}_j that occurs c_j times in \mathcal{V} ,

$$\widehat{B}_j = \{b_{11}^j, \dots, b_{1c_j}^j, \dots, b_{n_j 1}^j, \dots, b_{n_j c_j}^j\}$$

is a unitary symmetry adapted basis. Then the submatrix of $\phi^{\widehat{B}}$ relating to the isotypic component V_j consists of a diagonal of n_j identical blocks of size c_j . It is given by

$$I_{n_j} \otimes \left(\mu_{st}^j \right)_{1 \leq s, t \leq c_j} \quad \text{with } \mu_{st}^j = \phi(b_{1s}^j, b_{1t}^j).$$

Proof. We take unitary representing matrices $\left(r_{\alpha\beta}^j(g) \right)_{1 \leq \alpha, \beta \leq n_j}$ for all irreducible representations \mathcal{V}_j .

Using Remark 6.7, for every $s = 1, \dots, c_k$ (resp. for every $t = 1, \dots, c_\ell$), the set $\{b_{1s}^k, \dots, b_{n_k s}^k\}$ (resp. the set $\{b_{1t}^\ell, \dots, b_{n_\ell t}^\ell\}$) is a basis of an irreducible subspace contained in the isotypic component V_k (resp. V_ℓ). We deduce from Proposition 6.6 that

$$\mathcal{V}(g)(b_{\alpha s}^k) = \sum_{\gamma=1}^{n_k} r_{\gamma\alpha}^k(g) b_{\gamma s}^k \quad \forall \alpha = 1, \dots, n_k \text{ and } \mathcal{V}(g)(b_{\beta t}^\ell) = \sum_{\delta=1}^{n_\ell} r_{\delta\beta}^\ell(g) b_{\delta t}^\ell \quad \forall \beta = 1, \dots, n_\ell.$$

Since the map ϕ is a G -invariant Hermitian form, we also have

$$\phi(b_{\alpha s}^k, b_{\beta t}^\ell) = \frac{1}{|G|} \sum_{g \in G} \phi(\mathcal{V}(g)(b_{\alpha s}^k), \mathcal{V}(g)(b_{\beta t}^\ell)) \quad \forall \alpha = 1, \dots, n_k, \forall \beta = 1, \dots, n_\ell.$$

This leads to

$$\phi(b_{\alpha s}^k, b_{\beta t}^\ell) = \sum_{\substack{1 \leq \gamma \leq n_k \\ 1 \leq \delta \leq n_\ell}} \left(\frac{1}{|G|} \sum_{g \in G} r_{\gamma\alpha}^k(g) \overline{r_{\delta\beta}^\ell(g)} \right) \phi(b_{\gamma s}^k, b_{\delta t}^\ell) \quad \forall \alpha = 1, \dots, n_k, \forall \beta = 1, \dots, n_\ell.$$

We deduce then from the *orthogonality relations for irreducible representations of G* [24, Corollary 5.2] that

$$\phi(b_{\alpha s}^k, b_{\beta t}^\ell) = \begin{cases} \frac{1}{n_k} \sum_{\gamma=1}^{n_k} \phi(b_{\gamma s}^k, b_{\delta t}^\ell) & \text{if } k = \ell \text{ and } \alpha = \beta \\ 0 & \text{otherwise.} \end{cases}$$

The matrix $\phi^{\widehat{B}}$ of the G -invariant Hermitian form ϕ in the basis \widehat{B} has thus the expected block diagonal structure. \square

6.4 Orthogonal symmetry adapted bases

In the previous sections, we showed that representation theory can be used to compute a basis such that the matrix of a G -invariant Hermitian form on a \mathbb{C} -vector space has a block diagonal structure. Similarly, representation theory can be used to compute a basis such that the matrix of any symmetric bilinear form on a \mathbb{R} -vector space, which is invariant under a linear representation of a finite group, is block diagonal.

Based on [75, Chapter 13.2], we study the linear representations on a \mathbb{R} -vector space from the linear representations on a \mathbb{C} -vector space. In fact, any linear representation \mathcal{V} on a \mathbb{R} -vector space V can be considered as a linear representation on the \mathbb{C} -vector space $V \otimes_{\mathbb{R}} \mathbb{C}$, that is the vector space obtained from V by extending the scalars from the real numbers to the complex numbers.

We recall the three types of irreducible representations on a \mathbb{C} -vector space distinguished in [75, Chapter 13.2]. Let \mathcal{V}_j be an irreducible representation of a finite group G on a n_j -dimensional \mathbb{C} -vector space V_j and let χ_j be its character. The three mutually exclusive cases are the following:

1. The representation \mathcal{V}_j can be realized by matrices having coefficients in \mathbb{R} , in which case the character χ_j is a real-valued function. By restriction of the scalars from the complex numbers to the real numbers, \mathcal{V}_j defines an irreducible representation $\mathcal{V}_j^{(j)}$ on a \mathbb{R} -vector space of dimension n_j with character χ_j .
2. The character χ_j is not real-valued. By restriction of the scalars, \mathcal{V}_j defines an irreducible representation $\mathcal{V}_j^{(j)}$ on a \mathbb{R} -vector space of dimension $2n_j$ with character $\chi_j + \overline{\chi_j}$.
3. The character χ_j is a real-valued function, but the representation \mathcal{V}_j cannot be realized by matrices having coefficients in \mathbb{R} . By restriction of the scalars, \mathcal{V}_j defines an irreducible representation $\mathcal{V}_j^{(j)}$ on a \mathbb{R} -vector space of dimension $2n_j$ with character $2\chi_j$.

An irreducible representation $\mathcal{V}_j^{(j)}$ on a \mathbb{R} -vector space defined thanks to an irreducible representation \mathcal{V}_j of type 1 (resp. of type 2, of type 3) is called *absolutely irreducible* (resp. of

complex type, of quaternionian type) [29]. Irreducible representation of quaternionian type are not considered in this paper as they do not arise in our application.

In the case of a representation of a finite group on a \mathbb{C} -vector space, we presented in Section 6.2 a construction of a unitary symmetry adapted basis for every isotypic component. Similarly, given a representation \mathcal{V} of a finite group G on a \mathbb{R} -vector space V , we present now a construction of an *orthogonal symmetry adapted basis* for every isotypic component of the \mathbb{R} -vector space V ; that is a basis such that, for every $g \in G$, the matrix of the representation \mathcal{V} restricted to this isotypic component in this basis is

$$(r_{\alpha\beta}(g))_{1 \leq \alpha, \beta \leq n} \otimes I_c,$$

where n is the dimension of the irreducible representation associated with this isotypic component, c is the number of times it occurs in \mathcal{V} and $(r_{\alpha\beta}(g))_{1 \leq \alpha, \beta \leq n}$ is an orthogonal matrix.

The construction of an orthogonal symmetry adapted basis is based on the one of a unitary symmetry adapted basis presented in Section 6.2. It depends on the type of each irreducible representation that occurs in the representation \mathcal{V} on the \mathbb{C} -vector space $V \otimes_{\mathbb{R}} \mathbb{C}$. Since in our applications we never encounter the case of an irreducible representation of quaternionian type, we do not present here a way of computing a basis in this case.

As in the case of unitary symmetry adapted bases, the union of orthogonal symmetry adapted bases associated with distinct irreducible representations is an orthogonal symmetry adapted basis.

We first give some notations. Given a \mathbb{C} -vector space V , we denote by \bar{V} the \mathbb{C} -vector space whose vectors are the complex conjugate of the vectors of V , that is $\bar{V} = \{z \mid \bar{z} \in V\}$. Given a linear representation \mathcal{V} of a group G on a n -dimensional \mathbb{C} -vector space V , we denote by $\bar{\mathcal{V}}$ the linear representation of the group G on the n -dimensional \mathbb{C} -vector space \bar{V} defined by

$$\bar{\mathcal{V}}(g)(\bar{z}) = \overline{\mathcal{V}(g)(z)} \quad \forall g \in G, \forall z \in V.$$

Let $B = \{v_1, \dots, v_n\}$ be a basis of V such that, for every $g \in G$, the representing matrix $\mathcal{V}^B(g) = (r_{\alpha\beta}(g))_{1 \leq \alpha, \beta \leq n}$ is unitary. We denote by \bar{B} the set $\{\bar{v}_1, \dots, \bar{v}_n\}$. The latter is a basis of the space \bar{V} . For every $g \in G$, the representing matrix $\bar{\mathcal{V}}^{\bar{B}}(g)$ is given by $(\overline{r_{\alpha\beta}(g)})_{1 \leq \alpha, \beta \leq n}$ and is unitary. The characters of the representations \mathcal{V} and $\bar{\mathcal{V}}$ are thus complex conjugate. Assuming that the representation \mathcal{V} is irreducible, the representation $\bar{\mathcal{V}}$ is therefore irreducible too.

Absolutely irreducible representation

Let \mathcal{V}_k be an irreducible n_k -dimensional representation of type 1 of the group G that appears c_k times in the representation \mathcal{V} on the space $V \otimes_{\mathbb{R}} \mathbb{C}$ and let V_k be the isotypic component of type \mathcal{V}_k . Here, for all $g \in G$, we can choose the representing matrices $(r_{\alpha\beta}^k(g))_{1 \leq \alpha, \beta \leq n_k}$ of the irreducible representation \mathcal{V}_k with coefficients in \mathbb{R} . Following [24, Chapter 1.11], we can also choose orthogonal representing matrices. We can thus copy the construction of a unitary symmetry adapted basis presented in Section 6.2.

For every $(\alpha, \beta) \in \mathbb{N}^2$ such that $1 \leq \alpha, \beta \leq n_k$, consider the linear map $p_{k,\alpha\beta} : V \otimes_{\mathbb{R}} \mathbb{C} \rightarrow V \otimes_{\mathbb{R}} \mathbb{C}$

defined here by

$$p_{k,\alpha\beta} = \frac{n_k}{|G|} \sum_{g \in G} r_{\alpha\beta}^k(g) \mathcal{V}(g)$$

and a basis $\{v_1, \dots, v_n\}$ of the representation space V . A basis $\{b_1, \dots, b_{c_k}\}$ of the subspace $p_{k,11}(V \otimes_{\mathbb{R}} \mathbb{C})$, where b_1, \dots, b_{c_k} are real vectors, is then obtained by taking c_k linearly independent vectors in $\{p_{k,11}(v_1), \dots, p_{k,11}(v_n)\}$. A unitary symmetry adapted basis of the isotypic component V_k is then given by

$$\widehat{B}_k = \{b_1, \dots, b_{c_k}, p_{k,21}(b_1), \dots, p_{k,21}(b_{c_k}), \dots, p_{k,n_k1}(b_1), \dots, p_{k,n_k1}(b_{c_k})\}.$$

The latter has furthermore real vectors. The basis \widehat{B}_k is then an orthogonal symmetry adapted basis of the space obtained by restricting the scalars of the isotypic component V_k . It is therefore denoted by B_k .

Irreducible representation of complex type

Let \mathcal{V}_ℓ be an irreducible n_ℓ -dimensional representation of type 2 of the group G with character χ_ℓ . Assume that \mathcal{V}_ℓ appears c_ℓ times in the representation \mathcal{V} on the space $V \otimes_{\mathbb{R}} \mathbb{C}$. By Theorem 6.3, we have

$$c_\ell = \frac{1}{|G|} \sum_{g \in G} \overline{\chi_\ell(g)} \chi(g).$$

Since the character χ of the representation \mathcal{V} is a real-valued function, we have

$$c_\ell = \overline{c_\ell} = \frac{1}{|G|} \sum_{g \in G} \chi_\ell(g) \overline{\chi(g)} = \frac{1}{|G|} \sum_{g \in G} \chi_\ell(g) \chi(g).$$

The representation $\overline{\mathcal{V}_\ell}$ appears then also c_ℓ times in the representation \mathcal{V} so that the isotypic component \overline{V}_ℓ of type $\overline{\mathcal{V}_\ell}$ has the same dimension as the isotypic component V_ℓ of type \mathcal{V}_ℓ . Since the characters χ_ℓ and $\overline{\chi_\ell}$ are not identical, the representations \mathcal{V}_ℓ and $\overline{\mathcal{V}_\ell}$ are inequivalent. The space $V_\ell \oplus \overline{V}_\ell$ is thus of dimension $2c_\ell n_\ell$.

For every $(\alpha, \beta) \in \mathbb{N}^2$ such that $1 \leq \alpha, \beta \leq n_\ell$, let $p_{\ell,\alpha\beta} : V \otimes_{\mathbb{R}} \mathbb{C} \rightarrow V \otimes_{\mathbb{R}} \mathbb{C}$ be the linear map defined by

$$p_{\ell,\alpha\beta} = \frac{n_\ell}{|G|} \sum_{g \in G} r_{\alpha\beta}^\ell(g) \mathcal{V}(g),$$

where $\left(r_{\alpha\beta}^\ell(g)\right)_{1 \leq \alpha, \beta \leq n_\ell}$ are unitary representing matrices of \mathcal{V}_ℓ . Let $\{b_1, \dots, b_{c_\ell}\}$ be a basis of the subspace $p_{\ell,11}(V \otimes_{\mathbb{R}} \mathbb{C})$, the set

$$\widehat{B}_\ell = \{b_1, \dots, b_{c_\ell}, p_{\ell,21}(b_1), \dots, p_{\ell,21}(b_{c_\ell}), \dots, p_{\ell,n_\ell1}(b_1), \dots, p_{\ell,n_\ell1}(b_{c_\ell})\}$$

is a unitary symmetry adapted basis of the isotypic component V_ℓ . In addition, the basis \widehat{B}_ℓ corresponds to the unitary symmetry adapted basis of the space \overline{V}_ℓ computed with the help of the linear maps

$$\overline{p_{\ell,\alpha\beta}} = \frac{n_\ell}{|G|} \sum_{g \in G} r_{\alpha\beta}^\ell(g) \mathcal{V}(g) \quad \forall 1 \leq \alpha, \beta \leq n_\ell.$$

The complex conjugate bases \widehat{B}_ℓ and $\overline{\widehat{B}_\ell}$ form then a basis of the space $V_\ell \oplus \overline{V}_\ell$. In order to obtain a basis B_ℓ of the space $V_\ell \oplus \overline{V}_\ell$ with real vectors, we can choose the basis

$$B_\ell = \left\{ \frac{1}{2}(b_1 + \overline{b_1}), \dots, \frac{1}{2}(b_{c_\ell} + \overline{b_{c_\ell}}), \frac{1}{2i}(b_1 - \overline{b_1}), \dots, \frac{1}{2i}(b_{c_\ell} - \overline{b_{c_\ell}}), \dots, \right. \\ \left. \frac{1}{2}(p_{\ell, n_\ell 1}(b_1) + \overline{p_{\ell, n_\ell 1}(b_1)}), \dots, \frac{1}{2}(p_{\ell, n_\ell 1}(b_{c_\ell}) + \overline{p_{\ell, n_\ell 1}(b_{c_\ell})}), \right. \\ \left. \frac{1}{2i}(p_{\ell, n_\ell 1}(b_1) - \overline{p_{\ell, n_\ell 1}(b_1)}), \dots, \frac{1}{2i}(p_{\ell, n_\ell 1}(b_{c_\ell}) - \overline{p_{\ell, n_\ell 1}(b_{c_\ell})}) \right\}.$$

Notice that, by Proposition 6.6, we have

$$\frac{1}{2}(p_{\ell, \alpha 1}(b_\gamma) + \overline{p_{\ell, \alpha 1}(b_\gamma)}) = (p_{\ell, \alpha 1} + \overline{p_{\ell, \alpha 1}}) \left(\frac{b_\gamma + \overline{b_\gamma}}{2} \right) \quad \forall \alpha = 1, \dots, n_\ell, \forall \gamma = 1, \dots, c_\ell,$$

$$\frac{1}{2i}(p_{\ell, \alpha 1}(b_\gamma) - \overline{p_{\ell, \alpha 1}(b_\gamma)}) = (p_{\ell, \alpha 1} + \overline{p_{\ell, \alpha 1}}) \left(\frac{b_\gamma - \overline{b_\gamma}}{2i} \right) \quad \forall \alpha = 1, \dots, n_\ell, \forall \gamma = 1, \dots, c_\ell.$$

The basis B_ℓ can then be computed as follows:

- Take a basis $\{b_1, \dots, b_{c_\ell}\}$ of the subspace $p_{\ell, 11}(V \otimes_{\mathbb{R}} \mathbb{C})$.
- Let $u_\gamma = \operatorname{Re}(b_\gamma)$ and $v_\gamma = \operatorname{Im}(b_\gamma)$ for all $\gamma = 1, \dots, c_\ell$. Compute $(p_{\ell, \alpha 1} + \overline{p_{\ell, \alpha 1}})(u_\gamma)$ and $(p_{\ell, \alpha 1} + \overline{p_{\ell, \alpha 1}})(v_\gamma)$ for all $\alpha = 2, \dots, n_\ell$ and for all $\gamma = 1, \dots, c_\ell$.
- The basis B_ℓ is then given by

$$B_\ell = \left\{ u_1, \dots, u_{c_\ell}, v_1, \dots, v_{c_\ell}, \dots, \right. \\ \left. (p_{\ell, n_\ell 1} + \overline{p_{\ell, n_\ell 1}})(u_1), \dots, (p_{\ell, n_\ell 1} + \overline{p_{\ell, n_\ell 1}})(u_{c_\ell}), \right. \\ \left. (p_{\ell, n_\ell 1} + \overline{p_{\ell, n_\ell 1}})(v_1), \dots, (p_{\ell, n_\ell 1} + \overline{p_{\ell, n_\ell 1}})(v_{c_\ell}) \right\}.$$

For every $g \in G$, the matrix of the representation \mathcal{V} restricted to the space $V_\ell \oplus \overline{V}_\ell$ in the basis B_ℓ is

$$\mathcal{V}^{(\ell)}(g) \otimes I_{c_\ell} = \begin{pmatrix} s_{11}^\ell(g) & t_{11}^\ell(g) & \cdots & s_{1n_\ell}^\ell(g) & t_{1n_\ell}^\ell(g) \\ -t_{11}^\ell(g) & s_{11}^\ell(g) & \cdots & -t_{1n_\ell}^\ell(g) & s_{1n_\ell}^\ell(g) \\ \vdots & \vdots & & \vdots & \vdots \\ s_{n_\ell 1}^\ell(g) & t_{n_\ell 1}^\ell(g) & \cdots & s_{n_\ell n_\ell}^\ell(g) & t_{n_\ell n_\ell}^\ell(g) \\ -t_{n_\ell 1}^\ell(g) & s_{n_\ell 1}^\ell(g) & \cdots & -t_{n_\ell n_\ell}^\ell(g) & s_{n_\ell n_\ell}^\ell(g) \end{pmatrix} \otimes I_{c_\ell}, \quad (6.3)$$

with $s_{\alpha\beta}^\ell(g) = \frac{1}{2} \left(r_{\alpha\beta}^\ell(g) + \overline{r_{\alpha\beta}^\ell(g)} \right)$ and $t_{\alpha\beta}^\ell(g) = \frac{1}{2i} \left(r_{\alpha\beta}^\ell(g) - \overline{r_{\alpha\beta}^\ell(g)} \right)$ for all $(\alpha, \beta) \in \mathbb{N}^2$ such that $1 \leq \alpha, \beta \leq n_\ell$. The matrices $\mathcal{V}^{(\ell)}(g)$ correspond to the representing matrices of an irreducible representation of complex type with character $\chi_\ell + \overline{\chi}_\ell$.

Lemma 6.9. *The matrices $\mathcal{V}^{(\ell)}(g)$ are orthogonal for all $g \in G$.*

Proof. Let $g \in G$. Since the matrix $\left(r_{\alpha\beta}^\ell(g) \right)_{1 \leq \alpha, \beta \leq n_\ell}$ is unitary, we have

$$\left(r_{\alpha\beta}^\ell(g) \right)_{1 \leq \alpha, \beta \leq n_\ell} \left(\overline{r_{\alpha\beta}^\ell(g)} \right)_{1 \leq \alpha, \beta \leq n_\ell}^t = I_{2n_\ell}, \quad (6.4)$$

which is equivalent to the following system of n^2 equations

$$\sum_{\gamma=1}^{n_\ell} r_{\alpha\gamma}^\ell(g) \overline{r_{\beta\gamma}^\ell(g)} = \delta_{\alpha\beta} \quad \forall 1 \leq \alpha, \beta \leq n_\ell.$$

The matrix $\mathcal{V}^{(\ell)}(g)$ is orthogonal if and only if $\mathcal{V}^{(\ell)}(g)\mathcal{V}^{(\ell)}(g)^t = I_{2n_\ell}$. This matrix equation is equivalent to the following system of $4n_\ell^2$ equations:

$$\begin{cases} \sum_{\gamma=1}^{n_\ell} (s_{\alpha\gamma}^\ell(g) s_{\beta\gamma}^\ell(g) + t_{\alpha\gamma}^\ell(g) t_{\beta\gamma}^\ell(g)) = \delta_{\alpha\beta} & \forall 1 \leq \alpha, \beta \leq 2n_\ell \text{ and } \alpha, \beta \text{ with the same parity} \\ \sum_{\gamma=1}^{n_\ell} (s_{\alpha\gamma}^\ell(g) t_{\beta\gamma}^\ell(g) - s_{\beta\gamma}^\ell(g) t_{\alpha\gamma}^\ell(g)) = 0 & \forall 1 \leq \alpha, \beta \leq 2n_\ell \text{ and } \alpha, \beta \text{ of different parity.} \end{cases}$$

For each equation, we use the definition of the coefficients $s_{\alpha\beta}^\ell(g)$ and $t_{\alpha\beta}^\ell(g)$ and expand the left hand side. Thus, this system is equivalent to

$$\begin{cases} \frac{1}{2} \sum_{\gamma=1}^{n_\ell} (\overline{r_{\alpha\gamma}^\ell(g)} r_{\beta\gamma}^\ell(g) + r_{\alpha\gamma}^\ell(g) \overline{r_{\beta\gamma}^\ell(g)}) = \delta_{\alpha\beta} & \forall 1 \leq \alpha, \beta \leq 2n_\ell \text{ and } \alpha, \beta \text{ with the same parity} \\ \frac{1}{2i} \sum_{\gamma=1}^{n_\ell} (\overline{r_{\alpha\gamma}^\ell(g)} r_{\beta\gamma}^\ell(g) - r_{\beta\gamma}^\ell(g) \overline{r_{\alpha\gamma}^\ell(g)}) = 0 & \forall 1 \leq \alpha, \beta \leq 2n_\ell \text{ and } \alpha, \beta \text{ of different parity.} \end{cases}$$

With the help of (6.4), the system is satisfied so that the matrix $\mathcal{V}^{(\ell)}(g)$ is orthogonal. \square

The basis B_ℓ is then an orthogonal symmetry adapted basis of the space obtained by restricting the scalars of $V_\ell \oplus \overline{V}_\ell$ from the complex numbers to the real numbers.

6.5 Invariant symmetric bilinear forms

In this section, we present an analogue result to the block diagonalization of the matrix of an invariant Hermitian form in a unitary symmetry basis. Orthogonal symmetry adapted bases are now used to block diagonalize matrices of symmetric bilinear forms invariant under a representation of a finite group.

Remark 6.10. In what follows, we assume that a representation \mathcal{V} on a \mathbb{R} -vector space V does not contain an irreducible representation of quaternionian type : it contains only absolutely irreducible representations or irreducible representations of complex type.

Consider an orthogonal symmetry adapted basis B of V that is computed as described in Section 6.4. The isotypic decomposition of $V \otimes_{\mathbb{R}} \mathbb{C}$ can be written as follows

$$V \otimes_{\mathbb{R}} \mathbb{C} = V_1 \oplus \cdots \oplus V_M \oplus V_{M+1} \oplus \cdots \oplus V_N \oplus \overline{V_{M+1}} \oplus \cdots \oplus \overline{V_N},$$

where the isotypic component V_j for $j = 1, \dots, M$ is associated with an irreducible representation of type 1 and the pair (V_j, \overline{V}_j) for $j = M + 1, \dots, N$ is associated with an irreducible representation of type 2 and its complex conjugate. The basis B of V respects then the following decomposition deduced from the isotypic decomposition of $V \otimes_{\mathbb{R}} \mathbb{C}$

$$V = U_1 \oplus \cdots \oplus U_M \oplus U_{M+1} \oplus \cdots \oplus U_N, \tag{6.5}$$

where U_j is the space obtained by restricting the scalars of V_j for every $j = 1, \dots, M$ and the space obtained by restricting the scalars of $V_j \oplus \overline{V}_j$ for every $j = M + 1, \dots, N$.

Let \mathcal{V} be a representation of a finite group G on a n -dimensional \mathbb{R} -vector space V . A map $\varphi : V \times V \rightarrow \mathbb{R}$ is said to be a G -invariant symmetric bilinear form if it satisfies

$$\begin{aligned} \varphi(\lambda u + v, w) &= \lambda\varphi(u, w) + \varphi(v, w) & \forall \lambda \in \mathbb{R}, \forall u, v, w \in V, \\ \varphi(u, \lambda v + w) &= \lambda\varphi(u, v) + \varphi(u, w) & \forall \lambda \in \mathbb{R}, \forall u, v, w \in V, \\ \varphi(u, v) &= \varphi(v, u) & \forall u, v \in V \\ \text{and } \varphi(\mathcal{V}(g)(u), \mathcal{V}(g)(v)) &= \varphi(u, v) & \forall g \in G, \forall u, v \in V. \end{aligned}$$

The matrix $(\varphi(b_i, b_j))_{1 \leq i, j \leq n}$ of the symmetric bilinear form φ in a given basis $B = \{b_1, \dots, b_n\}$ is denoted by φ^B .

Proposition 6.11. *Let \mathcal{V} be a representation of a finite group G on a \mathbb{R} -vector space V and let $\varphi : V \times V \rightarrow \mathbb{R}$ be a G -invariant symmetric bilinear form. Consider U_1, \dots, U_N the components in the decomposition of V deduced from the isotypic decomposition of $V \otimes_{\mathbb{R}} \mathbb{C}$. Then*

$$\varphi(u, v) = 0 \quad \forall (u, v) \in U_i \times U_j \text{ with } i \neq j.$$

Hence the matrix φ^B of φ in any basis $B = B_1 \cup \dots \cup B_N$ that respects this decomposition of V is block diagonal.

Assume furthermore that, for every component U_j , B_j is an orthogonal symmetry adapted basis.

1. For every component U_j associated with an absolutely irreducible n_j -dimensional representation $\mathcal{V}^{(j)}$ that appears c_j times in the representation \mathcal{V} , the basis B_j can be written as

$$B_j = \{b_{11}^j, \dots, b_{1c_j}^j, \dots, b_{n_j1}^j, \dots, b_{n_jc_j}^j\}.$$

Then the submatrix of φ^B relating to the component U_j consists of a diagonal of n_j identical blocks of size c_j . It is given by

$$I_{n_j} \otimes \left(\nu_{st}^j \right)_{1 \leq s, t \leq c_j} \quad \text{with } \nu_{st}^j = \varphi(b_{1s}^j, b_{1t}^j).$$

2. For every component U_j associated with an irreducible $2n_j$ -dimensional representation $\mathcal{V}^{(j)}$ of complex type that appears c_j times in the representation \mathcal{V} , the basis B_j can be written as

$$B_j = \{a_{11}^j, \dots, a_{1c_j}^j, b_{11}^j, \dots, b_{1c_j}^j, \dots, a_{n_j1}^j, \dots, a_{n_jc_j}^j, b_{n_j1}^j, \dots, b_{n_jc_j}^j\}.$$

Then the submatrix of φ^B relating to the component U_j consists of a diagonal of n_j identical blocks of size $2c_j$. It is given by

$$I_{n_j} \otimes \begin{pmatrix} S_j & -A_j \\ A_j & S_j \end{pmatrix},$$

where $S_j = \left(\varphi(a_{1s}^j, a_{1t}^j) \right)_{1 \leq s, t \leq c_j} = \left(\varphi(b_{1s}^j, b_{1t}^j) \right)_{1 \leq s, t \leq c_j}$ is a symmetric matrix

and $A_j = \left(\varphi(a_{1s}^j, b_{1t}^j) \right)_{1 \leq s, t \leq c_j} = - \left(\varphi(b_{1s}^j, a_{1t}^j) \right)_{1 \leq s, t \leq c_j}$ is an antisymmetric matrix.

Proof. Let ϕ be the map defined by

$$\phi : (V \otimes_{\mathbb{R}} \mathbb{C}) \times (V \otimes_{\mathbb{R}} \mathbb{C}) \rightarrow \mathbb{C}, (z_1, z_2) \mapsto \varphi(u_1, u_2) + \varphi(v_1, v_2) + i \varphi(v_1, u_2) - i \varphi(u_1, v_2),$$

where $u_i = \operatorname{Re}(z_i)$ and $v_i = \operatorname{Im}(z_i)$ for $i = 1, 2$. The map ϕ is a G -invariant Hermitian form that satisfies $\phi(u, v) = \varphi(u, v)$ for all real vectors u and v .

Let \widehat{B} be a unitary symmetry adapted basis of the \mathbb{C} -vector space $V \otimes_{\mathbb{R}} \mathbb{C}$ and let $\widehat{B}_j \subset \widehat{B}$ be a unitary symmetry adapted basis of an isotypic component V_j of $V \otimes_{\mathbb{R}} \mathbb{C}$. Then, by Proposition 6.8, the submatrix of $\phi^{\widehat{B}}$ relating to an isotypic component V_j is

$$I_{n_j} \otimes \left(\mu_{st}^j \right)_{1 \leq s, t \leq c_j},$$

where c_j is the number of times that the irreducible n_j -dimensional representation associated with V_j occurs in the representation \mathcal{V} on $V \otimes_{\mathbb{R}} \mathbb{C}$.

As described in Section 6.4, for each component U_j , we can construct an orthogonal symmetry adapted basis B_j from the unitary symmetry adapted bases \widehat{B}_j . Following this construction and Proposition 6.8, we immediately have

$$\phi(u, v) = 0 \quad \forall (u, v) \in U_i \times U_j \text{ with } i \neq j.$$

We distinguish now two cases:

1. The component U_j is associated with an absolutely irreducible n_j -dimensional representation that occurs c_j times in the representation \mathcal{V} on the \mathbb{R} -vector space V . Following the construction of the orthogonal symmetry adapted basis B_j in Section 6.4, the submatrix of φ^B relating to the component U_j is

$$I_{n_j} \otimes \left(\nu_{st}^j \right)_{1 \leq s, t \leq c_j}.$$

2. The component U_j is associated with an irreducible $2n_j$ -dimensional representation of complex type that occurs c_j times in the representation \mathcal{V} on the \mathbb{R} -vector space V . Let $z_1, z_2 \in \widehat{B}_j$. We have then $u_1, u_2, v_1, v_2 \in B_j$, where $u_i = \operatorname{Re}(z_i)$ and $v_i = \operatorname{Im}(z_i)$ for $i = 1, 2$. If z_1 and z_2 do not belong to the same subspace $V_{j,\alpha}$ in the decomposition (6.2) of the isotypic component V_j of $V \otimes_{\mathbb{R}} \mathbb{C}$, then

$$\phi(u_1, u_2) = \phi(u_1, v_2) = \phi(v_1, u_2) = \phi(v_1, v_2) = 0.$$

Thus, the submatrix of φ^B relating to the component U_j consists of n_j identical blocks of size $2c_j$. In addition, since z_1 and \bar{z}_1 do not belong to the same isotypic component of $V \otimes_{\mathbb{R}} \mathbb{C}$, we have

$$\phi(\bar{z}_1, z_2) = 0,$$

or equivalently

$$\varphi(u_1, u_2) - \varphi(v_1, v_2) - i \varphi(v_1, u_2) - i \varphi(u_1, v_2) = 0.$$

This means that

$$\varphi(u_1, u_2) = \varphi(v_1, v_2) \text{ and } \varphi(v_1, u_2) = -\varphi(u_1, v_2)$$

so that every block of size $2c_j$ has the expected form $\begin{pmatrix} S_j & -A_j \\ A_j & S_j \end{pmatrix}$.

□

7 Matrix of multiplicities

This section is devoted to the introduction of the matrix of multiplicities of a finite group G and its computation when the group is cyclic or dihedral. It is the key in the determination of the block size of the matrix of the Hankel operator expressed in a symmetry adapted basis. Ultimately it provides us with preliminary criteria of existence of symmetric cubatures. \mathbb{K} is either \mathbb{R} or \mathbb{C} .

The entries of this matrix are the multiplicities of the irreducible inequivalent representations $\mathcal{V}_1, \dots, \mathcal{V}_N$ of the group G in specific representations: the *types* $\mathcal{P}_1, \dots, \mathcal{P}_T$ of the group G . They are the permutation representations associated with the coset spaces $G/H_1, \dots, G/H_T$, where H_1, \dots, H_T form a maximal family of non-conjugate subgroups of G . A column of this matrix gives the multiplicities of all irreducible inequivalent representations of G in a type.

The coset spaces $G/H_1, \dots, G/H_T$ and the orbits of any action of the group G are closely linked. It is then possible to describe the permutation representation of G associated with any invariant finite set: the multiplicity of every irreducible inequivalent representation (over \mathbb{R} or over \mathbb{C}) in the permutation representation can be expressed in terms of the entries of the matrix of multiplicities and a description related to the types $\mathcal{P}_1, \dots, \mathcal{P}_T$ of the finite set.

In the context of cubatures in the plane, the natural symmetries to consider are the actions of the cyclic groups C_m or dihedral groups D_m . We compute the matrices of multiplicities of C_m and D_m , with $m \geq 2$.

7.1 Permutation representations

Let G be a finite group with neutral element 1_G acting on a finite set \mathcal{O} . This means that each element $g \in G$ permutes the elements of \mathcal{O} and that the following identities are satisfied

$$1_G \zeta = \zeta, \quad g_1(g_2\zeta) = (g_1g_2)\zeta, \quad \forall g_1, g_2 \in G, \forall \zeta \in \mathcal{O}.$$

Let V be a \mathbb{K} -vector space having a basis $(e_\zeta)_{\zeta \in \mathcal{O}}$ indexed by the elements of \mathcal{O} . For $g \in G$, let $\mathcal{V}(g)$ be the linear map from V into V which sends e_ζ to $e_{g\zeta}$; the linear representation of G thus obtained is called the *permutation representation* associated to \mathcal{O} . Its representing matrices in the basis $(e_\zeta)_{\zeta \in \mathcal{O}}$ have the property that each row and column has exactly one entry 1, the remaining entries being 0. They are called *permutation matrices*. The character χ of a permutation representation is

$$\chi(g) = \text{number of elements of } \mathcal{O} \text{ fixed by } g, \quad \forall g \in G.$$

The *regular representation* of a finite group G (see *e.g.* [75, Chapter 1.2 & Chapter 2.4] [24, Chapter 5.6.1]) is an example of a permutation representation. Let $|G|$ be the order of G and let V be a $|G|$ -dimensional \mathbb{C} -vector space with a basis $(e_h)_{h \in G}$ indexed by the elements h of the group G . The regular representation of the group G is defined by the linear maps

$$\mathcal{V}(g) : V \rightarrow V, e_h \mapsto e_{gh} \quad \forall g \in G.$$

Its character χ is given by

$$\chi(g) = \begin{cases} |G| & \text{if } g = 1_G \\ 0 & \text{if } g \neq 1_G. \end{cases}$$

With the help of this character and Theorem 6.3, the number of times that every irreducible inequivalent representation \mathcal{V}_j of the group G occurs in the regular representation is given by its dimension n_j . Thus, the following relation is satisfied

$$|G| = \sum_{j=1}^{\underline{N}} n_j^2,$$

where \underline{N} is the number of irreducible inequivalent representations.

Similarly, given a subgroup H of a finite group G , consider a \mathbb{K} -vector space V with a basis $(e_\zeta)_{\zeta \in G/H}$ indexed by the elements ζ of the *coset space* $G/H = \{gH \mid g \in G\}$. The linear maps

$$\mathcal{V}(g) : V \rightarrow V, e_\zeta \mapsto e_{g\zeta} \quad \forall g \in G$$

define a permutation representation of the finite group G on V . Its character χ_H is given by

$$\chi_H(g) = \begin{cases} |G/H| & \text{if } g \in H \\ 0 & \text{if } g \notin H. \end{cases}$$

Let T be the number of subgroups of a given finite group G up to conjugacy and let H_1, \dots, H_T be subgroups of G that are not pairwise conjugate. For every $k = 1, \dots, T$, the subgroup H_k is associated with its *coset space* $G/H_k = \{gH_k \mid g \in G\}$ and therefore with a permutation representation, called *type* and denoted by \mathcal{P}_k .

For every irreducible inequivalent representation \mathcal{V}_j ($j = 1, \dots, \underline{N}$) of G , its multiplicity γ_{jk} in \mathcal{P}_k can be computed with Theorem 6.3. We define the *matrix of multiplicities* of a finite group G as the $\underline{N} \times T$ integer matrix

$$\Gamma_G = (\gamma_{jk})_{1 \leq j \leq \underline{N}, 1 \leq k \leq T},$$

where the j^{th} row is associated with the irreducible representation \mathcal{V}_j of G and the k^{th} column corresponds to the type \mathcal{P}_k .

Remark 7.1. Assume that the irreducible representation \mathcal{V}_1 is the one defined by $\mathcal{V}_1(g) = 1$ for all $g \in G$. Then Theorem 6.3 implies that

$$\gamma_{1k} = 1 \quad \forall k = 1, \dots, T.$$

7.2 Orbits and isotropy subgroups

Let G be a finite group acting on a \mathbb{K} -vector space V . For every point $\zeta \in V$, the set

$$G_\zeta = \{g \in G \mid g\zeta = \zeta\}$$

is called the *isotropy subgroup* of ζ . Points on the same orbit have conjugate isotropy subgroups [32, Chapter XIII, Lemma 1.1]. More precisely,

$$G_{g\zeta} = gG_\zeta g^{-1} \quad \forall g \in G, \forall \zeta \in V. \quad (7.1)$$

The set of all points of V that have conjugate isotropy subgroups is called an *orbit type* of the action.

The *orbit-stabilizer theorem* [32, Chapter XIII, Proposition 1.2] shows that there is a bijection between the orbit $\mathcal{O}_\zeta = \{g\zeta \in V \mid g \in G\}$ of a point $\zeta \in V$ and the coset space $G/G_\zeta = \{gG_\zeta \mid g \in G\}$ of the subgroup G_ζ of G given by

$$\mathring{f}_\zeta : \mathcal{O}_\zeta \rightarrow G/G_\zeta, g\zeta \mapsto gG_\zeta.$$

This bijection is furthermore an *equivariant map*, that is it satisfies

$$\mathring{f}_\zeta(gy) = g\mathring{f}_\zeta(y) \quad \forall g \in G, \forall y \in \mathcal{O}_\zeta.$$

For every point $\zeta \in V$, the permutation representations associated with \mathcal{O}_ζ and G/G_ζ are then equivalent. The next result is a direct consequence.

Proposition 7.2. *Let \mathcal{O} be a union of orbits of the action of a finite group G on a \mathbb{C} -vector space (resp. on a \mathbb{R} -vector space). Assume that there are m_k orbits associated with the type \mathcal{P}_k . Then, for every $j = 1, \dots, N$ (resp. for every $j = 1, \dots, N$), the multiplicity c_j of the irreducible representation \mathcal{V}_j (resp. $\mathcal{V}^{(j)}$) in the permutation representation associated with \mathcal{O} is given by*

$$c_j = \sum_{k=1}^T m_k \gamma_{jk},$$

where T is the number of types of G and $(\gamma_{jk})_{1 \leq j \leq N, 1 \leq k \leq T}$ is the matrix of multiplicities of G .

7.3 The cyclic group C_m with $m \geq 2$

Presentation (see *e.g.* [75, Chapter 5.1] [24, Chapter 1.9.1])

The cyclic group C_m is the group of order m consisting of the powers $1, g, \dots, g^{m-1}$ of an element g such that $g^m = 1$. It can be realized as the group of rotations of the plane (resp. of the space) around a fixed point (resp. a fixed axis) through angles $\frac{2\ell\pi}{m}$ with $\ell = 0, \dots, m-1$. It is an abelian group. The irreducible representations of C_m are thus one-dimensional. There are m irreducible inequivalent 1-dimensional representations \mathcal{V}_j of characters χ_j defined by

$$\chi_j(g^\ell) = e^{(j-1)\ell \frac{2i\pi}{m}} \quad \forall \ell = 0, \dots, m-1.$$

Subgroups

Every subgroup of the cyclic group C_m is isomorphic to the cyclic group C_a with a a divisor of m . We consider that the subgroup consisting of the neutral element is isomorphic to C_1 . Moreover, for every divisor a of m , there is a subgroup of C_m of order a generated by the element $g^{\frac{m}{a}}$ of C_m :

$$\{1, g^{\frac{m}{a}}, \dots, g^{(a-1)\frac{m}{a}}\}.$$

The latter is the unique subgroup (up to conjugacy) isomorphic to C_a .

Coset spaces

Let a be a divisor of m . For ease of notation, we identify C_a with the unique subgroup of C_m of order a . The cyclic group C_a is abelian. It is therefore a normal subgroup. Thus, the coset space

$$C_m/C_a = \{[1], [g], \dots, [g^{\frac{m}{a}-1}]\} = \{[1], [g^{\frac{m}{a}-1}], \dots, [g^{(\frac{m}{a}-1)(\frac{m}{a}-1)}]\}$$

is a group of order $\frac{m}{a}$, generated by $[g^{\frac{m}{a}-1}]$ and therefore isomorphic to $C_{\frac{m}{a}}$. Notice that each class has exactly a elements of C_m .

Types

Let a_1, \dots, a_T be the divisors of m . The subgroups of C_m are isomorphic to C_{a_1}, \dots, C_{a_T} . Each one is unique up to conjugacy and is therefore associated with a type $\mathcal{P}_1, \dots, \mathcal{P}_T$: the permutation representation associated with the coset space isomorphic to $C_{\frac{m}{a_1}}, \dots, C_{\frac{m}{a_T}}$. For any $k = 1, \dots, T$, the type \mathcal{P}_k is defined by its character $\chi^{(k)} : C_m \rightarrow \mathbb{C}$

$$\chi^{(k)}(g^\ell) = \begin{cases} \frac{m}{a_k} & \text{if } \frac{m}{a_k} \text{ divides } \ell \\ 0 & \text{otherwise} \end{cases} \quad \forall \ell = 0, \dots, m-1.$$

Matrix of multiplicities $\Gamma_{C_m} = (\gamma_{jk})_{1 \leq j \leq N, 1 \leq k \leq T}$

Let $j = 1, \dots, m$ (here $\underline{N} = m$) and let $k = 1, \dots, T$. The multiplicity γ_{jk} can be computed thanks to Theorem 6.3

$$\gamma_{jk} = \frac{1}{|C_m|} \sum_{g \in C_m} \chi^{(k)}(g) \overline{\chi_j(g)} = \frac{1}{m} \sum_{\ell=0}^{a_k-1} \chi^{(k)}(g^{\ell \frac{m}{a_k}}) \overline{\chi_j(g^{\ell \frac{m}{a_k}})} = \frac{1}{a_k} \sum_{\ell=0}^{a_k-1} e^{-\frac{(j-1)\ell}{a_k} 2i\pi}.$$

If a_k divides $j-1$, then

$$e^{-(j-1)\frac{\ell}{a_k} 2i\pi} = 1.$$

If a_k does not divide $j-1$, then

$$\sum_{\ell=0}^{a_k-1} e^{-(j-1)\frac{\ell}{a_k} 2i\pi} = 0.$$

Thus,

$$\gamma_{jk} = \begin{cases} 1 & \text{if } a_k \text{ divides } j-1 \\ 0 & \text{otherwise} . \end{cases}$$

Example : matrix of multiplicities Γ_{C_6}

Let $\mathcal{P}_1, \mathcal{P}_2, \mathcal{P}_3, \mathcal{P}_4$ be the permutation representations respectively associated with the coset spaces isomorphic to C_1, C_2, C_3, C_6 . The matrix of multiplicities is then given by

$$\Gamma_{C_6} = \begin{pmatrix} 1 & 1 & 1 & 1 \\ 0 & 0 & 0 & 1 \\ 0 & 0 & 1 & 1 \\ 0 & 1 & 0 & 1 \\ 0 & 0 & 1 & 1 \\ 0 & 0 & 0 & 1 \end{pmatrix}.$$

An action of C_m on \mathbb{R}^2 : realization of C_m as the rotations around a fixed point

Only C_1 and C_m appear as isotropy subgroups for the action of C_m on \mathbb{R}^2 by rotation: the only point fixed by C_m is the origin. The corresponding submatrix of Γ_{C_m} is

$$\begin{pmatrix} 1 & 1 \\ 0 & 1 \\ \vdots & \vdots \\ 0 & 1 \end{pmatrix}.$$

Remark on reflection

Consider the action of C_2 on \mathbb{R}^2 whose generator is given by the reflection through an axis. The isotropy subgroups are again only C_1 and C_2 . Notice that, in this example, the points fixed by C_2 is not reduced to the origin (or to a unique point), but it consists of every point on the axis of reflection.

7.4 The dihedral group D_m with $m \geq 2$

Presentation (see *e.g.* [75, Chapter 5.3] [24, Chapter 1.9.2])

The dihedral group D_m is the group of rotations and reflections of the plane that preserve a regular polygon with m vertices. It contains m rotations, which form a subgroup isomorphic to C_m , and m reflections. Its order is $2m$. If we denote by g the rotation through an angle $\frac{2\pi}{m}$ and if h is any reflection, we have:

$$g^m = 1, \quad h^2 = 1, \quad hgh = g^{-1}.$$

Each element of D_m can be written uniquely, either in the form g^ℓ , with $\ell = 0, \dots, m-1$ (if it is a rotation), or in the form $g^\ell h$, with $\ell = 0, \dots, m-1$ (if it is a reflection).

Subgroups

Every subgroup of the dihedral group D_m is either isomorphic to the cyclic group C_a , or isomorphic to the dihedral group D_a , where a is a divisor of m . Notice that D_1 is isomorphic to C_2 .

If m is odd, then, for all $\ell = 0, \dots, m-1$, the reflections $g^\ell h$ are conjugate (see in [32, Chapter XII.5(b)]). Thus, for every a that divides m , there are up to conjugacy a unique subgroup isomorphic to the cyclic group C_a and a unique subgroup isomorphic to the dihedral group D_a .

If m is even, then, for all $\ell = 0, \dots, \frac{m}{2} - 2$, all reflections $g^{2\ell} h$ are conjugate, all reflections $g^{2\ell+1} h$ are conjugate, but h and gh are not conjugate (see [32, Chapter XII.5(b)]). Thus, for every a that divides m , there are up to conjugacy a unique subgroup isomorphic to the cyclic group C_a ($a \neq 2$) and one or two subgroups isomorphic to the dihedral group D_a ($a \neq 1$).

More precisely, there are two subgroups isomorphic to D_a that are not conjugate if $\frac{m}{a}$ is even ($a \neq 1$) and there is one subgroup isomorphic to D_a if $\frac{m}{a}$ is odd. Indeed, consider the two following subgroups of D_m :

$$D_a(h) = \{1, g^{\frac{m}{a}}, \dots, g^{(a-1)\frac{m}{a}}, h, g^{\frac{m}{a}}h, \dots, g^{(a-1)\frac{m}{a}}h\}$$

and

$$D_a(gh) = \{1, g^{\frac{m}{a}}, \dots, g^{(a-1)\frac{m}{a}}, gh, g^{\frac{m}{a}+1}h, \dots, g^{(a-1)\frac{m}{a}+1}h\}.$$

If $\frac{m}{a}$ is even, $D_a(h)$ only contains reflections $g^\ell h$ with ℓ even, whereas $D_a(gh)$ only contains reflections $g^\ell h$ with ℓ odd. Thus, the two subgroups are not conjugate. If $\frac{m}{a}$ is odd, both subgroups contain reflections $g^\ell h$ with ℓ odd and reflections $g^\ell h$ with ℓ even. Thus, the two subgroups are conjugate.

In addition, if m is even, there are up to conjugacy three subgroups isomorphic to C_2 (or D_1):

$$\{1, g^{\frac{m}{2}}\}, \quad D_1(h) = \{1, h\}, \quad D_1(gh) = \{1, gh\}.$$

Coset spaces

Let a be a divisor of m . In the following, for ease of notation, we identify C_a with the unique subgroup of D_m isomorphic to C_a , D_a with the subgroup of D_m isomorphic to D_a if its unique and we keep the notation $D_a(h)$ and $D_a(gh)$ introduced above if there are two subgroups isomorphic to D_a . Since $g_0 g^\ell g_0^{-1}$ is a rotation and $g_0(g^\ell h)g_0^{-1}$ is a reflection for all $g_0 \in D_m$ and for all $\ell = 0, \dots, m-1$, all subgroups of D_m are normal.

The coset space

$$D_m/C_a = \{[1], [g^{\frac{m}{a}-1}], \dots, [g^{(\frac{m}{a}-1)(\frac{m}{a}-1)}], [h], [g^{\frac{m}{a}-1}h], \dots, [g^{(\frac{m}{a}-1)(\frac{m}{a}-1)}h]\}$$

is then a group of order $2\frac{m}{a}$, generated by $[g^{\frac{m}{a}-1}]$ and $[h]$. Since its elements are either in the form $[g^{\frac{m}{a}-1}]^\ell$ with $\ell = 0, \dots, \frac{m}{a}$, or in the form $[g^{\frac{m}{a}-1}]^\ell [h]$ with $\ell = 0, \dots, \frac{m}{a}$, the coset space D_m/C_a is isomorphic to the dihedral group $D_{\frac{m}{a}}$. Notice that each class has exactly a elements of D_m .

The coset spaces D_m/D_a , $D_m/D_a(h)$ and $D_m/D_a(gh)$ can all be written as

$$\{[1], [g^{\frac{m}{a}-1}], \dots, [g^{(\frac{m}{a}-1)(\frac{m}{a}-1)}]\}.$$

They are groups of order $\frac{m}{a}$, generated by $[g^{\frac{m}{a}-1}]$ and therefore isomorphic to the cyclic group $C_{\frac{m}{a}}$. Notice that each class has exactly $2a$ elements of D_m . However, those elements are different according to the coset space. For instance, for D_m/D_a and $D_m/D_a(h)$,

$$[1] = \{1, g^{\frac{m}{a}}, \dots, g^{(a-1)\frac{m}{a}}, h, g^{\frac{m}{a}}h, \dots, g^{(a-1)\frac{m}{a}}h\},$$

whereas for $D_m/D_a(gh)$,

$$[1] = \{1, g^{\frac{m}{a}}, \dots, g^{(a-1)\frac{m}{a}}, gh, g^{\frac{m}{a}+1}h, \dots, g^{(a-1)\frac{m}{a}+1}h\}.$$

7.4.1 Case m odd

There are 2 irreducible inequivalent representations of dimension 1, denoted by $\mathcal{V}_1, \mathcal{V}_2$, and $\frac{m-1}{2}$ irreducible inequivalent representations of dimension 2, denoted by $\mathcal{V}_3, \dots, \mathcal{V}_{2+\frac{m-1}{2}}$ [75, Chapter 5.3]. They are defined by:

$$\begin{aligned} \mathcal{V}_1(g) &= 1 & \mathcal{V}_1(h) &= 1, \\ \mathcal{V}_2(g) &= 1 & \mathcal{V}_2(h) &= -1, \\ \mathcal{V}_j(g) &= \begin{pmatrix} \cos(\frac{2(j-2)\pi}{m}) & -\sin(\frac{2(j-2)\pi}{m}) \\ \sin(\frac{2(j-2)\pi}{m}) & \cos(\frac{2(j-2)\pi}{m}) \end{pmatrix} & \mathcal{V}_j(h) &= \begin{pmatrix} 1 & 0 \\ 0 & -1 \end{pmatrix} \quad \forall j = 3, \dots, 2 + \frac{m-1}{2}. \end{aligned}$$

Types

Let a_1, \dots, a_t (here $t = \frac{T}{2}$) be the divisors of m . The subgroups of D_m are isomorphic to $D_{a_1}, \dots, D_{a_t}, C_{a_1}, \dots, C_{a_t}$. Each one is unique up to conjugacy and is therefore associated with a type $\mathcal{P}_1, \dots, \mathcal{P}_T$: the permutation representation associated with the coset space isomorphic to $C_{\frac{m}{a_1}}, \dots, C_{\frac{m}{a_t}}, D_{\frac{m}{a_1}}, \dots, D_{\frac{m}{a_t}}$. The type \mathcal{P}_k is defined by its character $\chi^{(k)} : D_m \rightarrow \mathbb{C}$.

- If $k = 1, \dots, t$ and $\ell = 0, \dots, m-1$, then

$$\chi^{(k)}(g^\ell) = \begin{cases} \frac{m}{a_k} & \text{if } \frac{m}{a_k} \text{ divides } \ell \\ 0 & \text{otherwise} \end{cases} \quad \text{and} \quad \chi^{(k)}(g^\ell h) = \begin{cases} \frac{m}{a_k} & \text{if } \frac{m}{a_k} \text{ divides } \ell \\ 0 & \text{otherwise} \end{cases}.$$

- If $k = t+1, \dots, T$ and $\ell = 0, \dots, m-1$, then let $\alpha_k = a_{k-t}$

$$\chi^{(k)}(g^\ell) = \begin{cases} \frac{2m}{\alpha_k} & \text{if } \frac{m}{\alpha_k} \text{ divides } \ell \\ 0 & \text{otherwise} \end{cases} \quad \text{and} \quad \chi^{(k)}(g^\ell h) = 0.$$

Matrix of multiplicities $\Gamma_{D_m} = (\gamma_{jk})_{1 \leq j \leq N, 1 \leq k \leq T}$

Let $j = 1, \dots, N$ and let $k = 1, \dots, t$. The multiplicity γ_{jk} can be computed thanks to Theorem 6.3

$$\gamma_{jk} = \frac{1}{|D_m|} \sum_{g \in D_m} \chi^{(k)}(g) \overline{\chi_j(g)} = \frac{1}{2m} \left(\sum_{\ell=0}^{a_k-1} \chi^{(k)}(g^{\ell \frac{m}{a_k}}) \overline{\chi_j(g^{\ell \frac{m}{a_k}})} + \sum_{\ell=0}^{a_k-1} \chi^{(k)}(g^{\ell \frac{m}{a_k}} h) \overline{\chi_j(g^{\ell \frac{m}{a_k}} h)} \right).$$

For $j = 1$,

$$\gamma_{1k} = \frac{1}{2m} \left(\sum_{\ell=0}^{a_k-1} \frac{m}{a_k} \cdot 1 + \sum_{\ell=0}^{a_k-1} \frac{m}{a_k} \cdot 1 \right) = 1.$$

For $j = 2$,

$$\gamma_{2k} = \frac{1}{2m} \left(\sum_{\ell=0}^{a_k-1} \frac{m}{a_k} \cdot 1 + \sum_{\ell=0}^{a_k-1} \frac{m}{a_k} \cdot (-1) \right) = 0.$$

For $j = 3, \dots, 2 + \frac{m-1}{2}$,

$$\gamma_{jk} = \frac{1}{2m} \left(\sum_{\ell=0}^{a_k-1} \frac{m}{a_k} \cdot 2 \cos \left(\frac{2(j-2)\pi \ell m}{m a_k} \right) + \sum_{\ell=0}^{a_k-1} \frac{m}{a_k} \cdot 0 \right) = \begin{cases} 1 & \text{if } a_k \text{ divides } j-2 \\ 0 & \text{otherwise} \end{cases}.$$

Let $j = 1, \dots, \underline{N}$ and let $k = t+1, \dots, T$. The multiplicity γ_{jk} can be computed thanks to Theorem 6.3

$$\begin{aligned} \gamma_{jk} &= \frac{1}{|D_m|} \sum_{g \in D_m} \chi^{(k)}(g) \overline{\chi_j(g)} \\ &= \frac{1}{2m} \left(\sum_{\ell=0}^{\alpha_k-1} \chi^{(k)} \left(g^{\ell \frac{m}{\alpha_k}} \right) \overline{\chi_j \left(g^{\ell \frac{m}{\alpha_k}} \right)} + \sum_{\ell=0}^{\alpha_k-1} \chi^{(k)} \left(g^{\ell \frac{m}{\alpha_k}} h \right) \overline{\chi_j \left(g^{\ell \frac{m}{\alpha_k}} h \right)} \right). \end{aligned}$$

For $j = 1$,

$$\gamma_{1k} = \frac{1}{2m} \left(\sum_{\ell=0}^{\alpha_k-1} \frac{2m}{\alpha_k} \cdot 1 + \sum_{\ell=0}^{\alpha_k-1} 0 \cdot 1 \right) = 1.$$

For $j = 2$,

$$\gamma_{2k} = \frac{1}{2m} \left(\sum_{\ell=0}^{\alpha_k-1} \frac{2m}{\alpha_k} \cdot 1 + \sum_{\ell=0}^{\alpha_k-1} 0 \cdot (-1) \right) = 1.$$

For $j = 3, \dots, 2 + \frac{m-1}{2}$,

$$\gamma_{jk} = \frac{1}{2m} \left(\sum_{\ell=0}^{\alpha_k-1} \frac{2m}{\alpha_k} \cdot 2 \cos \left(\frac{2(j-2)\pi \ell m}{m \alpha_k} \right) + \sum_{\ell=0}^{\alpha_k-1} 0 \cdot 0 \right) = \begin{cases} 2 & \text{if } \alpha_k \text{ divides } j-2 \\ 0 & \text{otherwise} \end{cases}.$$

Example : matrix of multiplicities Γ_{D_3}

Let $\mathcal{P}_1, \mathcal{P}_2, \mathcal{P}_3, \mathcal{P}_4$ be the permutation representations respectively associated with the coset spaces isomorphic to C_1, C_3, D_1, D_3 . The matrix of multiplicities is then given by

$$\Gamma_{D_3} = \begin{pmatrix} 1 & 1 & 1 & 1 \\ 0 & 0 & 1 & 1 \\ 0 & 1 & 0 & 2 \end{pmatrix}.$$

Action of D_m on \mathbb{R}^2 that fix a polygon with m vertices

This action implies a representation \mathcal{W} of D_m on \mathbb{R}^2 : it is generated by

$$\mathcal{W}(g) = \begin{pmatrix} \cos(\frac{2\pi}{m}) & -\sin(\frac{2\pi}{m}) \\ \sin(\frac{2\pi}{m}) & \cos(\frac{2\pi}{m}) \end{pmatrix} \text{ and } \mathcal{W}(h) = \begin{pmatrix} 1 & 0 \\ 0 & -1 \end{pmatrix}$$

and is therefore given by

$$[\mathcal{W}(g)^0, \mathcal{W}(g)^1, \dots, \mathcal{W}(g)^{m-1}, \mathcal{W}(g)^0\mathcal{W}(h), \mathcal{W}(g)^1\mathcal{W}(h), \dots, \mathcal{W}(g)^{m-1}\mathcal{W}(h)].$$

The isotropy subgroups associated with this action of D_m on \mathbb{R}^2 are C_1 , D_1 and D_m . The unique point fixed by D_m is the center of gravity of the polygon and the points fixed by a subgroup isomorphic to D_1 are the ones on the symmetry axis of the polygon (see [32, Chapter XIII.5] for more details).

The corresponding submatrix of Γ_{D_m} is

$$\begin{pmatrix} 1 & 1 & 1 \\ 0 & 0 & 1 \\ 0 & 1 & 2 \\ \vdots & \vdots & \vdots \\ 0 & 1 & 2 \end{pmatrix}.$$

In the case $m = 3$, the orbit types are then characterized by the 3 cases in Figure 3.

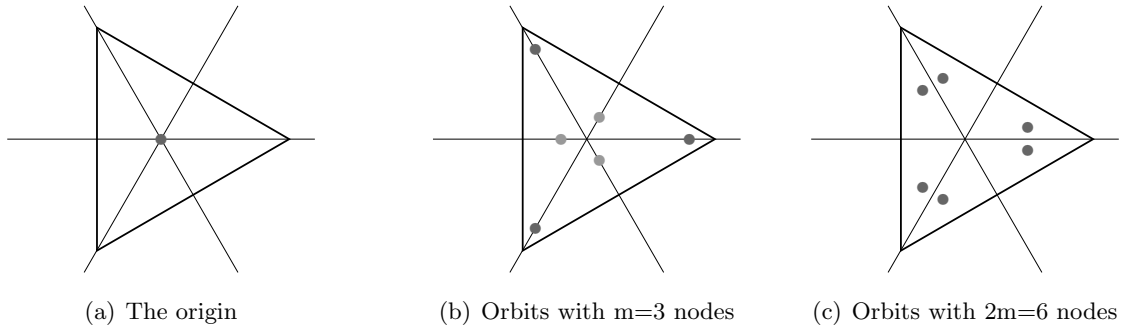

Figure 3: Orbit types for the action of D_3 on \mathbb{R}^2

7.4.2 Case m even

There are 4 irreducible inequivalent representations of dimension 1, denoted by $\mathcal{V}_1, \mathcal{V}_2, \mathcal{V}_3, \mathcal{V}_4$, and $\frac{m}{2} - 1$ irreducible inequivalent representations of dimension 2, denoted by $\mathcal{V}_5, \dots, \mathcal{V}_{3+\frac{m}{2}}$ if $m \neq 2$ [24, Chapter 1.9] [75, Chapter 5.3]. Notice that if $m = 2$, there is no irreducible

inequivalent representation of dimension 2. The irreducible representations \mathcal{V}_j are defined by:

$$\begin{aligned} \mathcal{V}_1(g) &= 1 & \mathcal{V}_1(h) &= 1, \\ \mathcal{V}_2(g) &= 1 & \mathcal{V}_2(h) &= -1, \\ \mathcal{V}_3(g) &= -1 & \mathcal{V}_3(h) &= 1, \\ \mathcal{V}_4(g) &= -1 & \mathcal{V}_4(h) &= -1, \\ \mathcal{V}_j(g) &= \begin{pmatrix} \cos(\frac{2(j-4)\pi}{m}) & -\sin(\frac{2(j-4)\pi}{m}) \\ \sin(\frac{2(j-4)\pi}{m}) & \cos(\frac{2(j-4)\pi}{m}) \end{pmatrix} & \mathcal{V}_j(h) &= \begin{pmatrix} 1 & 0 \\ 0 & -1 \end{pmatrix} \quad \forall j = 5, \dots, 3 + \frac{m}{2}. \end{aligned}$$

Types

Let a_1, \dots, a_t be the divisors of m . The subgroups of D_m are isomorphic to $D_{a_1}, \dots, D_{a_t}, C_{a_1}, \dots, C_{a_t}$ (with $C_2 \simeq D_1$). They are not necessarily unique up to conjugacy (see above the distinction between $D_a(h)$ and $D_a(gh)$ in the case $\frac{m}{a}$ even). Let τ be the number of non-conjugate subgroups isomorphic to D_{a_1}, \dots, D_{a_t} : we have then $T = \tau + t$ non-conjugate subgroups of D_m . Each one is associated with a type $\mathcal{P}_1, \dots, \mathcal{P}_T$. For every $k = 1, \dots, T$, the type \mathcal{P}_k is defined by its character $\chi^{(k)} : D_m \rightarrow \mathbb{C}$.

- If $k = 1, \dots, \tau$ and if the type \mathcal{P}_k is the permutation representation associated with a coset space D_m/D_a or $D_m/D_a(h)$, where a is the appropriate divisor of m , then for every $\ell = 0, \dots, m-1$

$$\chi^{(k)}(g^\ell) = \begin{cases} \frac{m}{a} & \text{if } \frac{m}{a} \text{ divides } \ell \\ 0 & \text{otherwise} \end{cases} \quad \text{and} \quad \chi^{(k)}(g^\ell h) = \begin{cases} \frac{m}{a} & \text{if } \frac{m}{a} \text{ divides } \ell \\ 0 & \text{otherwise} \end{cases}.$$

- If $k = 1, \dots, \tau$ and if the type \mathcal{P}_k is the permutation representation associated with a coset space $D_m/D_a(gh)$, where a is the appropriate divisor of m , then for every $\ell = 0, \dots, m-1$

$$\chi^{(k)}(g^\ell) = \begin{cases} \frac{m}{a} & \text{if } \frac{m}{a} \text{ divides } \ell \\ 0 & \text{otherwise} \end{cases} \quad \text{and} \quad \chi^{(k)}(g^{\ell+1}h) = \begin{cases} \frac{m}{a} & \text{if } \frac{m}{a} \text{ divides } \ell \\ 0 & \text{otherwise} \end{cases}.$$

- If $k = \tau + 1, \dots, T$, then let $\alpha_k = a_{k-\tau}$

$$\chi^{(k)}(g^\ell) = \begin{cases} \frac{2m}{\alpha_k} & \text{if } \frac{m}{\alpha_k} \text{ divides } \ell \\ 0 & \text{otherwise} \end{cases} \quad \text{and} \quad \chi^{(k)}(g^{\ell+1}h) = 0 \quad \forall \ell = 0, \dots, m-1.$$

Matrix of multiplicities $\Gamma_{D_m} = (\gamma_{jk})_{1 \leq j \leq N, 1 \leq k \leq T}$

Let $j = 1, \dots, N$ and let $k = 1, \dots, \tau$. The multiplicity γ_{jk} of the type \mathcal{P}_k associated with a coset space $D_m/D_a, D_m/D_a(h)$ or $D_m/D_a(gh)$ can be computed thanks to Theorem 6.3

$$\begin{aligned} \gamma_{jk} &= \frac{1}{|D_m|} \sum_{g \in D_m} \chi^{(k)}(g) \overline{\chi_j(g)} \\ &= \begin{cases} \frac{1}{2m} \left(\sum_{\ell=0}^{a-1} \chi^{(k)}(g^{\ell \frac{m}{a}}) \overline{\chi_j(g^{\ell \frac{m}{a}})} + \sum_{\ell=0}^{a-1} \chi^{(k)}(g^{\ell \frac{m}{a}} h) \overline{\chi_j(g^{\ell \frac{m}{a}} h)} \right) & \text{for } D_a, D_a(h) \\ \frac{1}{2m} \left(\sum_{\ell=0}^{a-1} \chi^{(k)}(g^{\ell \frac{m}{a}}) \overline{\chi_j(g^{\ell \frac{m}{a}})} + \sum_{\ell=0}^{a-1} \chi^{(k)}(g^{\ell \frac{m}{a} + 1} h) \overline{\chi_j(g^{\ell \frac{m}{a} + 1} h)} \right) & \text{for } D_a(gh). \end{cases} \end{aligned}$$

For $j = 1$,

$$\gamma_{1k} = \frac{1}{2m} \left(\sum_{\ell=0}^{a-1} \frac{m}{a} \cdot 1 + \sum_{\ell=0}^{a-1} \frac{m}{a} \cdot 1 \right) = 1.$$

For $j = 2$,

$$\gamma_{2k} = \frac{1}{2m} \left(\sum_{\ell=0}^{a-1} \frac{m}{a} \cdot 1 + \sum_{\ell=0}^{a-1} \frac{m}{a} \cdot (-1) \right) = 0.$$

For $j = 5, \dots, 3 + \frac{m}{2}$,

$$\gamma_{jk} = \frac{1}{2m} \left(\sum_{\ell=0}^{a-1} \frac{m}{a} \cdot 2 \cos \left(\frac{2(j-4)\pi \ell m}{m a} \right) + \sum_{\ell=0}^{a-1} \frac{m}{a} \cdot 0 \right) = \begin{cases} 2 & \text{if } a \text{ divides } j-4 \\ 0 & \text{otherwise} \end{cases}.$$

There is a difference when computing γ_{3k} and γ_{4k} .

- If \mathcal{P}_k is associated with a coset space D_m/D_a , then

$$\begin{cases} \gamma_{3k} = \frac{1}{2m} \left(\sum_{\ell=0}^{a-1} \frac{m}{a} \cdot (-1)^{\ell \frac{m}{a}} + \sum_{\ell=0}^{a-1} \frac{m}{a} \cdot (-1)^{\ell \frac{m}{a}} \right) = 0. \\ \gamma_{4k} = \frac{1}{2m} \left(\sum_{\ell=0}^{a-1} \frac{m}{a} \cdot (-1)^{\ell \frac{m}{a}} + \sum_{\ell=0}^{a-1} \frac{m}{a} \cdot (-1)^{\ell \frac{m}{a} + 1} \right) = 0. \end{cases}$$

- If \mathcal{P}_k is associated with a coset space $D_m/D_a(h)$, then

$$\begin{cases} \gamma_{3k} = \frac{1}{2m} \left(\sum_{\ell=0}^{a-1} \frac{m}{a} \cdot (-1)^{\ell \frac{m}{a}} + \sum_{\ell=0}^{a-1} \frac{m}{a} \cdot (-1)^{\ell \frac{m}{a}} \right) = 1. \\ \gamma_{4k} = \frac{1}{2m} \left(\sum_{\ell=0}^{a-1} \frac{m}{a} \cdot (-1)^{\ell \frac{m}{a}} + \sum_{\ell=0}^{a-1} \frac{m}{a} \cdot (-1)^{\ell \frac{m}{a} + 1} \right) = 0. \end{cases}$$

- If \mathcal{P}_k is associated with a coset space $D_m/D_a(gh)$, then

$$\begin{cases} \gamma_{3k} = \frac{1}{2m} \left(\sum_{\ell=0}^{a-1} \frac{m}{a} \cdot (-1)^{\ell \frac{m}{a}} + \sum_{\ell=0}^{a-1} \frac{m}{a} \cdot (-1)^{\ell \frac{m}{a} + 1} \right) = 0. \\ \gamma_{4k} = \frac{1}{2m} \left(\sum_{\ell=0}^{a-1} \frac{m}{a} \cdot (-1)^{\ell \frac{m}{a}} + \sum_{\ell=0}^{a-1} \frac{m}{a} \cdot (-1)^{\ell \frac{m}{a}} \right) = 1. \end{cases}$$

Let $j = 1, \dots, \underline{N}$ and let $k = \tau + 1, \dots, T$. The multiplicity γ_{jk} can be computed thanks to Theorem 6.3

$$\begin{aligned} \gamma_{jk} &= \frac{1}{|D_m|} \sum_{g \in D_m} \chi^{(k)}(g) \overline{\chi_j(g)} \\ &= \frac{1}{2m} \left(\sum_{\ell=0}^{\alpha_k-1} \chi^{(k)}(g^{\ell \frac{m}{\alpha_k}}) \overline{\chi_j(g^{\ell \frac{m}{\alpha_k}})} + \sum_{\ell=0}^{\alpha_k-1} \chi^{(k)}(g^{\ell \frac{m}{\alpha_k} h}) \overline{\chi_j(g^{\ell \frac{m}{\alpha_k} h})} \right). \end{aligned}$$

For $j = 1$,

$$\gamma_{1k} = \frac{1}{2m} \left(\sum_{\ell=0}^{\alpha_k-1} \frac{2m}{\alpha_k} \cdot 1 + \sum_{\ell=0}^{\alpha_k-1} 0 \cdot 1 \right) = 1.$$

For $j = 2$,

$$\gamma_{2k} = \frac{1}{2m} \left(\sum_{\ell=0}^{\alpha_k-1} \frac{2m}{\alpha_k} \cdot 1 + \sum_{\ell=0}^{\alpha_k-1} 0 \cdot (-1) \right) = 1.$$

For $j = 3$,

$$\gamma_{3k} = \frac{1}{2m} \left(\sum_{\ell=0}^{\alpha_k-1} \frac{2m}{\alpha_k} \cdot (-1)^{\ell \frac{m}{\alpha_k}} + \sum_{\ell=0}^{\alpha_k-1} 0 \cdot (-1)^{\ell \frac{m}{\alpha_k}} \right) = \begin{cases} 1 & \text{if } \alpha_k \text{ odd} \\ 0 & \text{if } \alpha_k \text{ even} \end{cases}.$$

For $j = 4$,

$$\gamma_{4k} = \frac{1}{2m} \left(\sum_{\ell=0}^{\alpha_k-1} \frac{2m}{\alpha_k} \cdot (-1)^{\ell \frac{m}{\alpha_k}} + \sum_{\ell=0}^{\alpha_k-1} 0 \cdot (-1)^{\ell \frac{m}{\alpha_k} + 1} \right) = \begin{cases} 1 & \text{if } \alpha_k \text{ odd} \\ 0 & \text{if } \alpha_k \text{ even} \end{cases}.$$

For $j = 5, \dots, 3 + \frac{m}{2}$,

$$\gamma_{jk} = \frac{1}{2m} \left(\sum_{\ell=0}^{\alpha_k-1} \frac{2m}{\alpha_k} \cdot 2 \cos \left(\frac{2(j-4)\pi \ell m}{m \alpha_k} \right) + \sum_{\ell=0}^{\alpha_k-1} 0 \cdot 0 \right) = \begin{cases} 2 & \text{if } \alpha_k \text{ divides } j-4 \\ 0 & \text{otherwise} \end{cases}.$$

Example : matrix of multiplicities Γ_{D_6}

Let $\mathcal{P}_1, \dots, \mathcal{P}_{10}$ be the permutation representations respectively associated with the coset spaces $D_6/D_6, D_6/D_3(h), D_6/D_3(gh), D_6/D_2, D_6/D_1(h), D_6/D_1(gh), D_6/C_6, D_6/C_3, D_6/C_2, D_6/C_1$. The matrix of multiplicities is then given by

$$\Gamma_{D_6} = \begin{pmatrix} 1 & 1 & 1 & 1 & 1 & 1 & 1 & 1 & 1 & 1 \\ 0 & 0 & 0 & 0 & 0 & 0 & 1 & 1 & 1 & 1 \\ 0 & 1 & 0 & 0 & 1 & 0 & 0 & 1 & 0 & 1 \\ 0 & 0 & 1 & 0 & 0 & 1 & 0 & 1 & 0 & 1 \\ 0 & 0 & 0 & 0 & 1 & 1 & 0 & 0 & 0 & 2 \\ 0 & 0 & 0 & 1 & 1 & 1 & 0 & 0 & 2 & 2 \end{pmatrix}.$$

Action of D_m on \mathbb{R}^2 that fix a polygon with m vertices

This action implies a representation \mathcal{W} of D_m on \mathbb{R}^2 : it is generated by

$$\mathcal{W}(g) = \begin{pmatrix} \cos(\frac{2\pi}{m}) & -\sin(\frac{2\pi}{m}) \\ \sin(\frac{2\pi}{m}) & \cos(\frac{2\pi}{m}) \end{pmatrix} \text{ and } \mathcal{W}(h) = \begin{pmatrix} 1 & 0 \\ 0 & -1 \end{pmatrix}$$

and is therefore given by

$$[\mathcal{W}(g)^0, \mathcal{W}(g)^1, \dots, \mathcal{W}(g)^{m-1}, \mathcal{W}(g)^0 \mathcal{W}(h), \mathcal{W}(g)^1 \mathcal{W}(h), \dots, \mathcal{W}(g)^{m-1} \mathcal{W}(h)].$$

The isotropy subgroups of this action of D_m on \mathbb{R}^2 are $C_1, D_1(h), D_1(gh), D_m$. The unique point fixed by D_m is the center of gravity of the polygon and the points fixed by a subgroup isomorphic to D_1 are the ones on the symmetry axis of the polygon: if the symmetry axis goes through the vertices, $D_1(h)$ fix its points, whereas if the symmetry axis goes through the middle of the edges, $D_1(gh)$ fix its points (see [32, Chapter XIII.5] for more details).

The corresponding submatrix of Γ_{D_m} is

$$\begin{pmatrix} 1 & 1 & 1 & 1 \\ 0 & 0 & 0 & 1 \\ 0 & 1 & 0 & 1 \\ 0 & 0 & 1 & 1 \\ 0 & 1 & 1 & 2 \\ \vdots & \vdots & \vdots & \vdots \\ 0 & 1 & 1 & 2 \end{pmatrix}.$$

In the case $m = 6$, the orbit types are then characterized by the 4 cases in Figure 4.

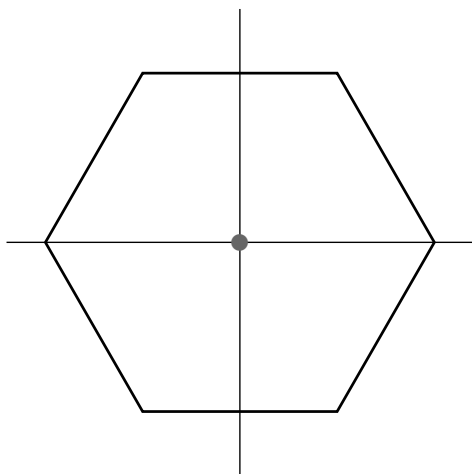

(a) The origin

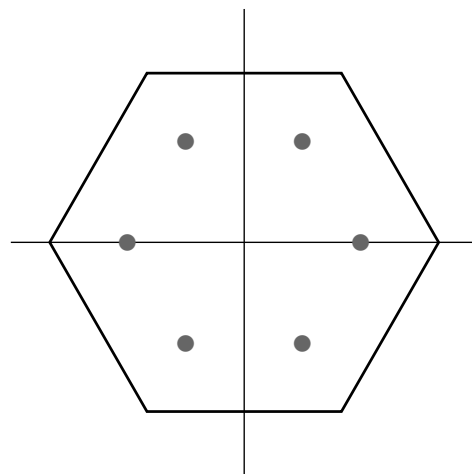

(b) Orbits with $m=6$ nodes: 2 on the x_1 -axis

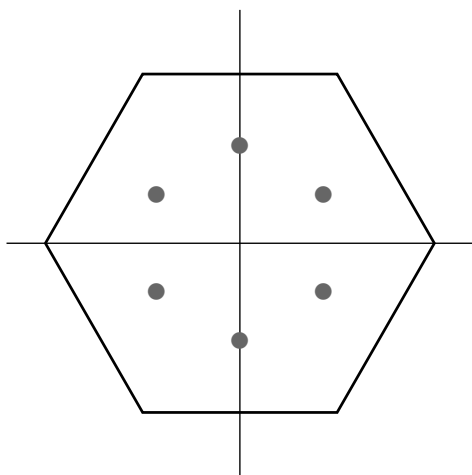

(c) Orbits with $m=6$ nodes: 2 on the x_2 -axis

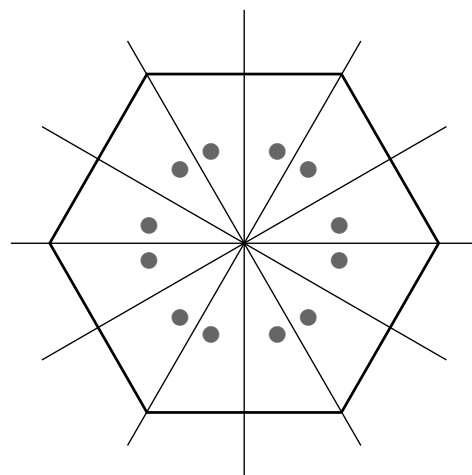

(d) Orbits with $2m=12$ nodes

Figure 4: Orbit types for the action of D_6 on \mathbb{R}^2

8 Hankel operators and symmetry

In Section 3, the Hankel operator associated with a linear form on $\mathbb{R}[x] = \mathbb{R}[x_1, \dots, x_n]$ is used to make explicit the properties and the defining elements of the linear form. This section is devoted to furthering this special connection in the presence of symmetry.

When the linear form is invariant under the linear action of a finite group, applying Section 6, we can determine a polynomial basis such that the matrix of the Hankel operator in this basis is block diagonal. This is also the case of the matrices of the linear operators \mathcal{H}_p on the quotient space when p is a G -invariant polynomial. The generalized eigenvalue problem that provides information on elements of the linear form is therefore transformed in several ones on smaller matrices.

In the special case of a G -invariant linear form defined by a linear combination of evaluations, the set of nodes is a union of orbits. With the matrix of multiplicities of the group G , we show how the types of the nodes in the orbits characterize the blocks of the linear operators on the quotient space: their size and the number of identical generalized eigenvalues per block.

In the cubature problem, it is not necessary to consider the generalized eigenvalue problems for all the blocks. The required ones are determined by the existence of a unimodular submatrix in the matrix of multiplicities.

8.1 Block diagonalization

The notions of G -invariant polynomials and linear forms are now defined. It is then proved that, for any G -invariant polynomial $p \in \mathbb{R}[x]$, the matrix of the linear operator \mathcal{H}_p associated with a G -invariant linear form Λ on $\mathbb{R}[x]$ in an orthogonal symmetry adapted basis of $\mathbb{R}[x]/I_\Lambda$ has a specific block diagonal structure.

Let \mathcal{W} be a linear representation of a finite group G on the space \mathbb{R}^n . A linear representation $\widehat{\mathcal{V}}$ of the group G on the polynomial space $\mathbb{R}[x]$ can be constructed as follows

$$\widehat{\mathcal{V}}(g) : \mathbb{R}[x] \rightarrow \mathbb{R}[x], p(x) \mapsto p(\mathcal{W}(g^{-1})(x)). \quad (8.1)$$

Notice that $\widehat{\mathcal{V}}(g)$ is an algebra morphism since $\widehat{\mathcal{V}}(g)(pq) = \widehat{\mathcal{V}}(g)(p) \widehat{\mathcal{V}}(g)(q)$ for all $p, q \in \mathbb{R}[x]$.

A polynomial $p \in \mathbb{R}[x]$ is said to be a G -invariant polynomial if it satisfies

$$\widehat{\mathcal{V}}(g)(p) = p \quad \forall g \in G.$$

Let π_G be the projection of $\mathbb{R}[x]$ onto the component associated with the one-dimensional absolutely irreducible representation with character χ defined by $\chi(g) = 1$ for all $g \in G$. Since for every polynomial $p \in \mathbb{R}[x]$

$$\pi_G(p) = \frac{1}{|G|} \sum_{g \in G} \widehat{\mathcal{V}}(g)(p)$$

defines a G -invariant polynomial, this component corresponds to the ring of all G -invariant polynomials $\mathbb{R}[x]^G$. The projection π_G is called *Reynolds operator* [79, Chapter 2.1].

A linear form Λ on $\mathbb{R}[x]$ is said to be G -invariant if it satisfies

$$\Lambda(\widehat{\mathcal{V}}(g)(p)) = \Lambda(p) \quad \forall g \in G, \forall p \in \mathbb{R}[x].$$

This implies that any G -invariant linear form Λ on $\mathbb{R}[x]$ satisfies

$$\Lambda(p) = \Lambda(\pi_G(p)) \quad \forall p \in \mathbb{R}[x]. \quad (8.2)$$

A G -invariant linear form on $\mathbb{R}[x]$ is therefore determined by its values on $\mathbb{R}[x]^G$.

In order to prove the main result of this section, we first present two lemmas.

Lemma 8.1. *Let $\widehat{\mathcal{V}}$ be the representation of a finite group G on the space $\mathbb{R}[x]$ induced by a representation \mathcal{W} on \mathbb{R}^n . Let Λ be a G -invariant linear form on $\mathbb{R}[x]$ and let I_Λ be the kernel of its associated Hankel operator. Then, for every $g \in G$, the subspace $I_\Lambda \subset \mathbb{R}[x]$ (resp. the variety $V_{\mathbb{C}}(I_\Lambda)$) is invariant under the isomorphism $\widehat{\mathcal{V}}(g)$ (resp. the isomorphism $\mathcal{W}(g)$).*

Proof. Let $g \in G$, let $p \in I_\Lambda$ and let $q \in \mathbb{R}[x]$. Since the linear form Λ is G -invariant, we have $\Lambda(\widehat{\mathcal{V}}(g)(p)q) = \Lambda(p\widehat{\mathcal{V}}(g^{-1})(q))$. The latter is zero since $p \in I_\Lambda$. Thus, $\widehat{\mathcal{V}}(g)(p) \in I_\Lambda$. The subspace I_Λ is then invariant under the isomorphism $\widehat{\mathcal{V}}(g)$.

Let $\xi \in V_{\mathbb{C}}(I_\Lambda)$. By definition of the representation $\widehat{\mathcal{V}}$, we have $\widehat{\mathcal{V}}(g)(p)(\xi) = p(\mathcal{W}(g^{-1})(\xi))$. Since $\widehat{\mathcal{V}}(g)(p) \in I_\Lambda$, we have $\mathcal{W}(g^{-1})(\xi) \in V_{\mathbb{C}}(I_\Lambda)$. The variety $V_{\mathbb{C}}(I_\Lambda)$ is then invariant under the isomorphism $\mathcal{W}(g^{-1})$. \square

Let $g \in G$ and $q_1, q_2 \in \mathbb{R}[x]$ such that $q_1 \equiv q_2 \pmod{I_\Lambda}$. Thanks to Lemma 8.1, we have then $\widehat{\mathcal{V}}(g)(q_1) \equiv \widehat{\mathcal{V}}(g)(q_2) \pmod{I_\Lambda}$. This implies that the linear operator

$$\mathcal{V}(g) : \mathbb{R}[x]/I_\Lambda \rightarrow \mathbb{R}[x]/I_\Lambda, [p] \mapsto [\widehat{\mathcal{V}}(g)(p)] \quad (8.3)$$

is well-defined. Thus, $\mathcal{V}(g)$ is an isomorphism from $\mathbb{R}[x]/I_\Lambda$ to itself and \mathcal{V} is a linear representation of the finite group G on the quotient space $\mathbb{R}[x]/I_\Lambda$.

Lemma 8.2. *Let $\widehat{\mathcal{V}}$ be the representation of a finite group G on the space $\mathbb{R}[x]$ induced by a representation \mathcal{W} on \mathbb{R}^n , let Λ be a G -invariant linear form on $\mathbb{R}[x]$ and let $p \in \mathbb{R}[x]$ be a G -invariant polynomial. Assume that the rank of the Hankel operator $\widehat{\mathcal{H}}$ associated with the linear form Λ is finite. Then the map φ_p defined by*

$$\varphi_p : \mathbb{R}[x]/I_\Lambda \times \mathbb{R}[x]/I_\Lambda \rightarrow \mathbb{R}, ([q_1], [q_2]) \mapsto \mathcal{H}_p([q_1])([q_2]) \quad \forall q_1, q_2 \in \mathbb{R}[x]$$

is a G -invariant symmetric bilinear form.

Proof. Let b_1, \dots, b_r be polynomials in $\mathbb{R}[x]$ such that B is a basis of $\mathbb{R}[x]/I_\Lambda$. By Theorem 3.7, the matrix $H_p^B = (\Lambda(pb_i b_j))_{1 \leq i, j \leq r}$ is the matrix of the linear operator \mathcal{H}_p in the basis B and its dual basis B^* . Thus, we have

$$\mathcal{H}_p([b_i])([b_j]) = \Lambda(pb_i b_j) = \mathcal{H}_p([b_j])([b_i]) \quad \forall 1 \leq i, j \leq r.$$

The map φ_p is therefore a symmetric bilinear form and H_p^B is also its matrix in the basis B .

It remains to show that φ_p is G -invariant. Let $g \in G$ and let $q_1, q_2 \in \mathbb{R}[x]$. By definition, we have

$$\begin{aligned} \varphi_p(\mathcal{V}(g)([q_1]), \mathcal{V}(g)([q_2])) &= \varphi_p([\widehat{\mathcal{V}}(g)(q_1)], [\widehat{\mathcal{V}}(g)(q_2)]) \\ &= \Lambda(p\widehat{\mathcal{V}}(g)(q_1)\widehat{\mathcal{V}}(g)(q_2)). \end{aligned}$$

Since the polynomial p is G -invariant, we have

$$\begin{aligned}\Lambda(p \widehat{\mathcal{V}}(g)(q_1) \widehat{\mathcal{V}}(g)(q_2)) &= \Lambda(\widehat{\mathcal{V}}(g)(p) \widehat{\mathcal{V}}(g)(q_1) \widehat{\mathcal{V}}(g)(q_2)) \\ &= \Lambda(\widehat{\mathcal{V}}(g)(pq_1q_2)).\end{aligned}$$

Since the linear form Λ is G -invariant, we have

$$\Lambda(\widehat{\mathcal{V}}(g)(pq_1q_2)) = \Lambda(pq_1q_2).$$

From the latter, we deduce that

$$\varphi_p(\mathcal{V}([q_1]), \mathcal{V}([q_2])) = \varphi_p([q_1], [q_2]).$$

□

In fact, Lemma 8.2 shows that a G -invariant linear form Λ on $\mathbb{R}[x]$ such that $\text{rank } \widehat{\mathcal{H}} < \infty$ defines a G -invariant symmetric bilinear form on $\mathbb{R}[x]/I_\Lambda$ for any G -invariant polynomial $p \in \mathbb{R}[x]$. With the help of Proposition 6.11, we obtain the following result:

Theorem 8.3. *Let $\widehat{\mathcal{V}}$ be a representation \mathcal{W} of a finite group G on \mathbb{R}^n . Let Λ be a G -invariant linear form on $\mathbb{R}[x]$ and assume that the rank of the Hankel operator $\widehat{\mathcal{H}}$ associated with the linear form Λ is finite. Let \mathcal{V} be the induced representation on $\mathbb{R}[x]/I_\Lambda$.*

Consider U_1, \dots, U_N the components in the decomposition of $\mathbb{R}[x]/I_\Lambda$ deduced from the isotypic decomposition of $\mathbb{R}[x]/I_\Lambda \otimes_{\mathbb{R}} \mathbb{C}$. Then, for any G -invariant polynomial $p \in \mathbb{R}[x]$ and for any basis $B = B_1 \cup \dots \cup B_N$ that respects this decomposition of $\mathbb{R}[x]/I_\Lambda$, the matrix H_p^B is block diagonal.

Assume furthermore that, for every component U_j , B_j is an orthogonal symmetry adapted basis.

1. *For every component U_j associated with an absolutely irreducible n_j -dimensional representation $\mathcal{V}^{(j)}$ that appears c_j times in the representation \mathcal{V} , the basis B_j can be written as*

$$B_j = \{b_{11}^j, \dots, b_{1c_j}^j, \dots, b_{n_j1}^j, \dots, b_{n_jc_j}^j\}.$$

Then the submatrix of H_p^B relating to the component U_j consists of a diagonal of n_j identical blocks of size c_j . It is given by

$$I_{n_j} \otimes \left(\nu_{st}^j \right)_{1 \leq s, t \leq c_j} \quad \text{with } \nu_{st}^j = \Lambda(\pi_G(b_{1s}^j b_{1t}^j)).$$

2. *For every component U_j associated with an irreducible $2n_j$ -dimensional representation $\mathcal{V}^{(j)}$ of complex type that appears c_j times in the representation \mathcal{V} , the basis B_j can be written as*

$$B_j = \{a_{11}^j, \dots, a_{1c_j}^j, b_{11}^j, \dots, b_{1c_j}^j, \dots, a_{n_j1}^j, \dots, a_{n_jc_j}^j, b_{n_j1}^j, \dots, b_{n_jc_j}^j\}.$$

Then the submatrix of H_p^B relating to the component U_j consists of a diagonal of n_j identical blocks of size $2c_j$. It is given by

$$I_{n_j} \otimes \begin{pmatrix} S_j & -A_j \\ A_j & S_j \end{pmatrix},$$

where $S_j = \left(\Lambda(\pi_G(a_{1s}^j a_{1t}^j)) \right)_{1 \leq s, t \leq c_j} = \left(\Lambda(\pi_G(b_{1s}^j b_{1t}^j)) \right)_{1 \leq s, t \leq c_j}$ is a symmetric matrix and $A_j = \left(\Lambda(\pi_G(a_{1s}^j b_{1t}^j)) \right)_{1 \leq s, t \leq c_j} = - \left(\Lambda(\pi_G(b_{1s}^j a_{1t}^j)) \right)_{1 \leq s, t \leq c_j}$ is an antisymmetric matrix.

Since the basis B in Theorem 8.3 does not depend on the G -invariant polynomial p , the following result is a consequence of Theorem 3.6 and Theorem 3.7.

Corollary 8.4. *With the hypotheses of Theorem 8.3, the matrix of the multiplication operator M_p in the basis B has the block diagonal structure described in Theorem 8.3.*

Proof. Let $p \in \mathbb{R}[x]$ be a G -invariant polynomial. By Theorem 8.3, the matrices H_1^B and H_p^B have the same block diagonal structure. By Theorem 3.6, the matrix H_1^B is invertible. Moreover, the matrix $(H_1^B)^{-1}$ has the same block diagonal structure as the matrix H_1^B . By Theorem 3.7, the matrix M_p^B is the product of the matrices $(H_1^B)^{-1}$ and H_p^B . Thus, the matrix M_p^B has the same block diagonal structure as H_1^B . \square

Notice that a similar result for symmetry adapted bases that do not need to be orthogonal is shown in [16, Corollary 5] for the fields $\mathbb{Q}, \mathbb{R}, \mathbb{C}$.

8.2 Block size

Consider the special case of a linear form Λ on $\mathbb{R}[x]$ defined by

$$\Lambda = \sum_{j=1}^r a_j \mathbb{1}_{\xi_j}$$

with $r > 0$, $a_j \in \mathbb{R} \setminus \{0\}$ and $\xi_j \in \mathbb{R}^n$ pairwise distinct. Let \mathcal{W} be a representation of a finite group G on \mathbb{R}^n and assume that the linear form Λ is G -invariant. Let \mathcal{V} be the induced representation on $\mathbb{R}[x]/I_\Lambda$. By Theorem 8.3, we can construct block diagonal matrices of the linear operators \mathcal{H} and \mathcal{H}_p associated with Λ when $p \in \mathbb{R}[x]$ is a G -invariant polynomial. In this section, we relate the organisation of the nodes in orbit types with the size of the blocks and the multiplicities of the generalized eigenvalues of the linear operators \mathcal{H}_p and \mathcal{H} thanks to the matrix of multiplicities Γ_G .

By Lemma 8.1, for every $g \in G$, the variety $V_{\mathbb{C}}(I_\Lambda) = \{\xi_1, \dots, \xi_r\} \subset \mathbb{R}^n$ is invariant under the isomorphism $\mathcal{W}(g)$. It is thus a union of orbits $\mathcal{O}_1, \dots, \mathcal{O}_{r_1}$ of the action defined by $G \times \mathbb{R}^n \rightarrow \mathbb{R}^n$, $(g, \xi) \mapsto \mathcal{W}(g)(\xi)$. The linear form Λ can thus be rewritten as

$$\Lambda = \sum_{\alpha=1}^{r_1} \check{a}_\alpha \sum_{\zeta_\alpha \in \mathcal{O}_\alpha} \mathbb{1}_{\zeta_\alpha}, \quad (8.4)$$

where $\check{a}_\alpha > 0$ is the common weight of the nodes ζ_α lying on the orbit \mathcal{O}_α .

A permutation representation is therefore associated with $V_{\mathbb{C}}(I_\Lambda)$. It is closely related to the representation \mathcal{V} on $\mathbb{R}[x]/I_\Lambda$ defined by (8.3) as shown in the next result.

Theorem 8.5. *Let Λ be the G -invariant linear form on $\mathbb{R}[x]$ defined by (8.4). The induced representation \mathcal{V} on $\mathbb{R}[x]/I_\Lambda$ is equivalent to the permutation representation associated with the invariant set $V_{\mathbb{C}}(I_\Lambda)$.*

Proof. The ideal I_Λ is zero-dimensional and radical. Following Corollary 3.5, we introduce polynomials f_1, \dots, f_r that satisfy $f_i(\xi_j) = \delta_{ij}$ and such that $C = \{[f_1], \dots, [f_r]\}$ is a basis of $\mathbb{R}[x]/I_\Lambda$.

Since the variety $V_{\mathbb{C}}(I_\Lambda)$ is furthermore an invariant set of \mathbb{R}^n , there exists a permutation $\sigma(g)$ for every $g \in G$ such that

$$\mathcal{W}(g)(\xi_j) = \xi_{\sigma(g)(j)} \quad \forall \xi_j \in V_{\mathbb{C}}(I_\Lambda).$$

Let $g \in G$ and let $i \in \{1, \dots, r\}$. Then, for every $\xi_j \in V_{\mathbb{C}}(I_\Lambda)$, we have

$$\widehat{\mathcal{V}}(g)(f_i)(\xi_j) = f_i(\mathcal{W}(g^{-1})(\xi_j)) = f_i(\xi_{\sigma(g^{-1})(j)}) = \delta_{i\sigma(g^{-1})(j)}.$$

Since $\delta_{i\sigma(g^{-1})(j)} = \delta_{\sigma(g)(i)j}$ for all $j = 1, \dots, r$, we have

$$\widehat{\mathcal{V}}(g)(f_i)(\xi_j) = f_{\sigma(g)(i)}(\xi_j) \quad \forall \xi_j \in V_{\mathbb{C}}(I_\Lambda).$$

Hence the polynomial $\widehat{\mathcal{V}}(g)(f_i) - f_{\sigma(g)(i)}$ vanishes on $V_{\mathbb{C}}(I_\Lambda)$. It follows from the *Strong Nullstellensatz* [17, Chapter 1.4] that $[\widehat{\mathcal{V}}(g)(f_i)] = [f_{\sigma(g)(i)}]$. In other words, $\mathcal{V}(g)([f_i]) = [f_{\sigma(g)(i)}]$.

For every $g \in G$, the representing matrix $\mathcal{V}^C(g)$ is then the matrix of the permutation $\sigma(g)$. \square

Proposition 7.2 and Theorem 8.5 can be used to express the multiplicities of the irreducible representations that appear in \mathcal{V} in terms of the orbit types of the elements of $V_{\mathbb{C}}(I_\Lambda)$.

Corollary 8.6. *Let Λ be the G -invariant linear form on $\mathbb{R}[x]$ defined by (8.4) and let \mathcal{V} be the representation on $\mathbb{R}[x]/I_\Lambda$ defined by (8.3).*

Let $(\gamma_{jk})_{1 \leq j \leq N, 1 \leq k \leq T}$ be the submatrix of the matrix of multiplicities Γ_G of the group G and, for every $k = 1, \dots, T$, let m_k be the number of distinct orbits in the invariant set $V_{\mathbb{C}}(I_\Lambda)$ associated with the type \mathcal{P}_k . The multiplicity γ_j of the irreducible representation $\mathcal{V}^{(j)}$ of G in the representation \mathcal{V} is

$$\gamma_j = \sum_{k=1}^T m_k \gamma_{jk}. \quad (8.5)$$

As described in Theorem 8.3, the multiplicity γ_j of an irreducible representation $\mathcal{V}^{(j)}$ is closely related to the size r_j of the blocks of the matrix H_p^B for any G -invariant polynomial $p \in \mathbb{R}[x]$ and any orthogonal symmetry adapted basis B of $\mathbb{R}[x]/I_\Lambda$. Equation (8.5) gives thus an important information on those blocks

$$r_j = \begin{cases} \gamma_j & \text{if } 1 \leq j \leq M \\ 2\gamma_j & \text{if } M+1 \leq j \leq N \end{cases}.$$

Remark 8.7. If $\mathcal{V}^{(1)}$ is the trivial representation of G , that is $\mathcal{V}^{(1)}(g) = 1$ for all $g \in G$, then using Remark 7.1 the size of the block associated with $\mathcal{V}^{(1)}$ is

$$r_1 = \gamma_1 = \sum_{k=1}^T m_k,$$

that is the number of distinct orbits in $V_{\mathbb{C}}(I_\Lambda)$.

For every $j = 1, \dots, N$, let $H_p^{(j)}$ be one of the identical blocks of the matrix H_p^B associated with the irreducible representation $\mathcal{V}^{(j)}$. By Corollary 3.9, the generalized eigenvalues of the pair of matrices (H_p^B, H_1^B) are the values of the G -invariant polynomial p on the invariant variety $V_{\mathbb{C}}(I_{\Lambda})$. Since the block diagonal structure is the same for all G -invariant polynomials, the computation of those generalized eigenvalues can be done using only the pairs of blocks $(H_p^{(j)}, H_1^{(j)})$. Theorem 8.5 and Corollary 8.6 can therefore be used to express their multiplicities in terms of the orbit types of the elements of $V_{\mathbb{C}}(I_{\Lambda})$.

Corollary 8.8. *Let Λ be the G -invariant linear form on $\mathbb{R}[x]$ defined by (8.4).*

Let B be an orthogonal symmetry adapted basis of $\mathbb{R}[x]/I_{\Lambda}$, let $p \in \mathbb{R}[x]$ be a G -invariant polynomial and let λ be a generalized eigenvalue of the pair of matrices (H_p^B, H_1^B) . For every $j = 1, \dots, N$, let \mathring{c}_j be the multiplicity of λ as a generalized eigenvalue of the pair of matrices $(H_p^{(j)}, H_1^{(j)})$ and, for every $k = 1, \dots, T$, let \mathring{m}_k be the number of distinct orbits \mathcal{O}_{α} associated with the type \mathcal{P}_k such that

$$\exists \zeta_{\alpha} \in \mathcal{O}_{\alpha} \text{ with } \lambda = p(\zeta_{\alpha}).$$

Two cases are to be distinguished:

1. *Assume that the pair of blocks $(H_p^{(j)}, H_1^{(j)})$ is relating to an absolutely irreducible representation $\mathcal{V}^{(j)}$. Then*

$$\mathring{c}_j = \sum_{k=1}^T \mathring{m}_k \gamma_{jk} \quad (1 \leq j \leq M).$$

2. *Assume that the pair of blocks $(H_p^{(j)}, H_1^{(j)})$ is relating to an irreducible representation $\mathcal{V}^{(j)}$ of complex type. Then*

$$\mathring{c}_j = 2 \sum_{k=1}^T \mathring{m}_k \gamma_{jk} \quad (M+1 \leq j \leq N).$$

Remark 8.9. If the pair of blocks $(H_p^{(1)}, H_1^{(1)})$ in Corollary 8.8 is relating to the trivial representation $\mathcal{V}^{(1)}$, then using Remark 7.1

$$\mathring{c}_1 = \sum_{k=1}^T \mathring{m}_k \geq 1.$$

The distinct generalized eigenvalues of the pair of matrices (H_p^B, H_1^B) are generalized eigenvalues of this pair of blocks $(H_p^{(1)}, H_1^{(1)})$.

For convenience, we introduce $\mathring{\mathring{c}}_j$ by

$$\mathring{\mathring{c}}_j = \begin{cases} \mathring{c}_j & \text{if } 1 \leq j \leq M \\ 2\mathring{c}_j & \text{if } M+1 \leq j \leq N \end{cases}.$$

Conversely, the numbers m_k in Corollary 8.6 (resp. \mathring{m}_k in Corollary 8.8) can be found from the multiplicities γ_j (resp. $\mathring{\mathring{c}}_j$) and the submatrix $(\gamma_{jk})_{1 \leq j \leq N, 1 \leq k \leq T}$ of the matrix of multiplicities

Γ_G . This is equivalent to solving over the integers the linear system

$$\begin{aligned} \begin{pmatrix} \gamma_1 \\ \vdots \\ \gamma_N \end{pmatrix} &= \begin{pmatrix} \gamma_{11} & \cdots & \gamma_{1T} \\ \vdots & & \vdots \\ \gamma_{N1} & \cdots & \gamma_{NT} \end{pmatrix} \begin{pmatrix} m_1 \\ \vdots \\ m_T \end{pmatrix} \\ \text{(resp. } \begin{pmatrix} \mathring{c}_1 \\ \vdots \\ \mathring{c}_M \\ \mathring{c}_{M+1} \\ \vdots \\ \mathring{c}_N \end{pmatrix} &= \begin{pmatrix} \gamma_{11} & \cdots & \gamma_{1T} \\ \vdots & & \vdots \\ \gamma_{M1} & \cdots & \gamma_{MT} \\ \gamma_{M+11} & \cdots & \gamma_{M+1T} \\ \vdots & & \vdots \\ \gamma_{N1} & \cdots & \gamma_{NT} \end{pmatrix} \begin{pmatrix} \mathring{m}_1 \\ \vdots \\ \mathring{m}_T \end{pmatrix} \text{)}. \end{aligned} \tag{8.6}$$

However, those linear systems may have more than a unique solution: two subgroups that are not conjugated may be associated with equivalent permutation representations [34].

In our application, we encounter matrices of multiplicities that have unimodular submatrices (determinant ± 1). Given the multiplicities, the above linear systems have at most one solution.

9 Algorithm for computing symmetric cubatures

In this section, a detailed description of our procedure for finding G -invariant cubatures is given. In contrast with Section 5, in this symmetric case, the size of the matrices in input of Algorithm 4.7 and the number of parameters are reduced. This is due to the block diagonalization of the matrix of the Hankel operator in an orthogonal symmetry adapted basis.

The problem of finding a symmetric cubature with a moment matrix approach can now be formulated as follows. Let μ be a positive Borel measure with compact support in \mathbb{R}^n such that

$$\text{supp } \mu = \{x \in \mathbb{R}^n \mid g_1(x) \geq 0, \dots, g_s(x) \geq 0\},$$

with $g_k(x) \in \mathbb{K}[x]$ for all $k = 1, \dots, s$. Let Ω be the linear form on $\mathbb{R}[x]$ defined from μ by

$$\Omega : \mathbb{R}[x] \rightarrow \mathbb{R}, p \mapsto \int_{\mathbb{R}^n} p(x) d\mu(x).$$

Assume furthermore that this linear form is G -invariant. This is the case for instance when μ is the characteristic function of the triangle ($G = D_3$), the square ($G = D_4$) or the hexagon ($G = D_6$). Notice that, if Ω is G -invariant, it is also invariant for all the subgroups of G so that when μ is the characteristic function of the disk, G may be any cyclic group C_m or any dihedral group D_m .

Given a degree d , we want to find for μ a G -invariant inside cubature Λ of degree d with positive weights. The invariant set of r nodes is partitioned into r_1 orbits $\mathcal{O}_1, \dots, \mathcal{O}_{r_1}$. The sought cubature Λ can thus be written as

$$\Lambda = \sum_{\alpha=1}^{r_1} \check{a}_\alpha \sum_{\zeta_\alpha \in \mathcal{O}_\alpha} \mathbb{1}_{\zeta_\alpha},$$

where $\check{a}_\alpha > 0$ is the common weight of the nodes ζ_α lying on the orbit \mathcal{O}_α .

The proposed procedure retains the structure of the one presented in Section 5:

1. Determination of the existence of such a G -invariant cubature (Section 9.2).
2. Computation of the coordinates of the nodes ζ_α and the common weights \check{a}_α for all the orbits \mathcal{O}_α with $\alpha = 1, \dots, r_1$ (Section 9.3).

In the first step, the computations are done using exact arithmetic in $\mathbb{K} \subset \mathbb{R}$ a field extension of \mathbb{Q} such that the moments of μ are in \mathbb{K} . For instance, $\mathbb{K} = \mathbb{Q}[\sqrt{2}]$ if μ is the characteristic function of a square, $\mathbb{K} = \mathbb{Q}[\sqrt{3}]$ if μ is the characteristic function of an equilateral triangle or a regular hexagon. We recall that moments of polytopes can be computed exactly following [3, 76].

We conclude this section with a new treatment of example of Section 5.4. In this symmetric case, the core of the computation of the nodes is reduced to dividing two numbers in $\mathbb{Q}[\sqrt{3}]$ and taking the square root of a number in \mathbb{Q} .

9.1 Initialization and subroutines

Before describing the procedure itself, we first introduce an algorithmic representation of the tools from representation theory: the irreducible inequivalent representations $\mathcal{V}^{(1)}, \dots, \mathcal{V}^{(N)}$ of a finite group G , any representation of G on \mathbb{R}^n , an orthogonal symmetry adapted basis of a polynomial space (Algorithm 9.3 [Symmetry Adapted Polynomial Basis]),... We describe then subroutines (Algorithm 9.4 [Symmetric Hankel Blocks] and Algorithm 9.5 [Parametrization Hankel Blocks]) used for the computation of the parameterized blocks in the matrix of the Hankel operator associated with the expected cubature Λ in an orthogonal symmetry adapted basis.

Finite group and irreducible representations

Let G be a finite group of order $|G|$ and let 1_G be its neutral element. The order of the elements of the group G is fixed

$$\{1_G, g_1, \dots, g_{|G|-1}\}. \quad (9.1)$$

Based on Section 6, the group G has a finite number of irreducible inequivalent representations, denoted by $\mathcal{V}_1, \dots, \mathcal{V}_N$ on \mathbb{C} -vector spaces (Theorem 6.2) and $\mathcal{V}^{(1)}, \dots, \mathcal{V}^{(N)}$ on \mathbb{R} -vector spaces (see the constructions done in Section 6.4).

Focusing on the ones on \mathbb{R} -vector spaces, we denote by M the number of absolutely irreducible representations. There are therefore $N - M$ irreducible representations of complex type since we assume that there is no irreducible representation of quaternionian type (Remark 6.10). Irreducible representations of complex type are obtained from 2 complex conjugate irreducible representations of type 2 so that: $\underline{N} = M + 2(N - M)$.

- Each of the M absolutely irreducible representation $\mathcal{V}^{(j)}$, if $1 \leq j \leq M$, is given by an ordered list of $|G|$ orthogonal $n_j \times n_j$ matrices (with entries in \mathbb{R}):

$$[\mathcal{V}^{(j)}(1_G), \mathcal{V}^{(j)}(g_1), \dots, \mathcal{V}^{(j)}(g_{|G|-1})].$$

The latter are representing matrices of the representation $\mathcal{V}^{(j)}$, or equivalently of \mathcal{V}_j .

- Each of the $N - M$ irreducible representation $\mathcal{V}^{(j)}$ of complex type, if $M + 1 \leq j \leq N$, is given by an ordered list of $|G|$ unitary $n_j \times n_j$ matrices (with entries in \mathbb{C}):

$$[\mathcal{V}^{(j)}(1_G), \mathcal{V}^{(j)}(g_1), \dots, \mathcal{V}^{(j)}(g_{|G|-1})].$$

The latter are representing matrices of one of the two complex conjugate irreducible representations \mathcal{V}_j of type 2 used to define $\mathcal{V}^{(j)}$.

The set of irreducible representations of the group G is given by a pair $[L_{abs}, L_{com}]$, where L_{abs} is a list of M absolutely irreducible inequivalent representations and L_{com} is a list of $N - M$ irreducible inequivalent representations of complex type.

Symmetry adapted basis

Let \mathcal{V} be a representation of a finite group G on a \mathbb{R} -vector space V . It is given by an ordered list of $|G|$ representing matrices that respects the order of the elements of the group G in (9.1). The size of the matrices is the dimension of the representation space V .

Such a representation \mathcal{V} can be completely reduced using the irreducible representations $\mathcal{V}^{(1)}, \dots, \mathcal{V}^{(N)}$. Their multiplicity c_1, \dots, c_N in \mathcal{V} can be computed thanks to Theorem 6.3.

Similarly to the set of irreducible inequivalent representations, any orthogonal symmetry adapted basis B is given by a pair $B = [[B_1, \dots, B_M], [B_{M+1}, \dots, B_N]]$. Each orthogonal symmetry adapted basis B_j is then given by a list

$$B_j = [B_{j1}, \dots, B_{jn_j}]$$

with

1.
$$B_{jk} = [b_{k1}^j, \dots, b_{kc_j}^j] \quad \text{if } 1 \leq j \leq M, \quad (9.2)$$

2.
$$B_{jk} = [a_{k1}^j, \dots, a_{kc_j}^j, b_{k1}^j, \dots, b_{kc_j}^j] \quad \text{if } M+1 \leq j \leq N. \quad (9.3)$$

The orthogonal symmetry adapted bases B_1, \dots, B_N are computed following Section 6.4. This provides the algorithm

Algorithm 9.1. Symmetry Adapted Basis

- Input : \triangleright A representation of the finite group G .
 \triangleright The set of irreducible representations of the group G .
Output : \triangleright An orthogonal symmetry adapted basis $B = [[B_1, \dots, B_M], [B_{M+1}, \dots, B_N]]$ of the representation space with $B_j = [B_{j1}, \dots, B_{jn_j}]$ and B_{jk} is
- either a list of c_j vectors if $1 \leq j \leq M$,
 - or a list of $2c_j$ vectors if $M+1 \leq j \leq N$.

Assume now that the finite group G acts linearly on \mathbb{R}^n . This implies a representation \mathcal{W} of G on \mathbb{R}^n . Let $\widehat{\mathcal{V}}$ be the induced representation of G on the polynomial space $\mathbb{R}[x]$ of all polynomials in n variables as in (8.1). For every $g \in G$, the image by the isomorphism $\widehat{\mathcal{V}}(g)$ of a homogeneous polynomial in $\mathbb{R}[x]$ is a homogeneous polynomial in $\mathbb{R}[x]$ of the same degree. It is therefore possible to consider the restriction of $\widehat{\mathcal{V}}$ to the space $\mathbb{R}[x]_{\leq \delta}$ for any degree $\delta \in \mathbb{N}$. Its representing matrices in a basis that respects the degree are block diagonal: one block per degree.

Those representing matrices are thus computed degree by degree. It is sufficient to:

1. Take any (monomial) basis $B_{\tilde{\delta}}$ of $\mathbb{R}[x]_{\tilde{\delta}}$, the space of homogeneous polynomials of degree exactly $\tilde{\delta}$, for every $0 \leq \tilde{\delta} \leq \delta$.
2. Express $\widehat{\mathcal{V}}(g)(b)(x) = b(\mathcal{W}(g^{-1})(x))$ in the basis $B_{\tilde{\delta}}$ for every $g \in G$ and $b \in B_{\tilde{\delta}}$. This gives the columns of the representing matrices.

This procedure describes the following algorithm.

Algorithm 9.2. Induced Representation

- Input : \triangleright A representation of a finite group G on \mathbb{R}^n .
 \triangleright A degree δ .
Output : \triangleright The induced representation of G on $\mathbb{R}[x]_{\leq \delta}$.

Combining Algorithm 9.1 and Algorithm 9.2 leads to the computation of an orthogonal symmetry adapted basis of the space $\mathbb{R}[x]_{\leq \delta}$ for a degree $\delta \in \mathbb{N}$:

Algorithm 9.3. Symmetry Adapted Polynomial Basis

- Input : \triangleright A representation of a finite group G on \mathbb{R}^n .
 \triangleright The set of irreducible representations of the group G .
 \triangleright A degree δ .
- Output : \triangleright An orthogonal symmetry adapted basis $[[B_1, \dots, B_M], [B_{M+1}, \dots, B_N]]$
 of $\mathbb{R}[x]_{\leq \delta}$ with $B_j = [B_{j1}, \dots, B_{jn_j}]$ and where
- $B_{jk} = [b_{k1}^j, \dots, b_{kc_j}^j]$ is a list of c_j polynomials if $1 \leq j \leq M$,
 - $B_{jk} = [a_{k1}^j, \dots, a_{kc_j}^j, b_{k1}^j, \dots, b_{kc_j}^j]$ is a list of $2c_j$ polynomials if $M + 1 \leq j \leq N$.

Since the computation of the bases B_{jk} is based on Algorithm 9.2, polynomials of the same degree are together in the list B_{jk} . We choose to order them such that

$$\begin{aligned} \deg a_{k\alpha}^j &\leq \deg a_{k\beta}^j \quad \forall 1 \leq k \leq n_j, \forall M + 1 \leq j \leq N, \forall 1 \leq \alpha < \beta \leq c_j, \\ \deg b_{k\alpha}^j &\leq \deg b_{k\beta}^j \quad \forall 1 \leq k \leq n_j, \forall 1 \leq j \leq N, \forall 1 \leq \alpha < \beta \leq c_j. \end{aligned}$$

Notice that by construction

$$\deg a_{k\ell}^j = \deg b_{k\ell}^j \quad \forall 1 \leq k \leq n_j, \forall 1 \leq j \leq N, \forall 1 \leq \ell \leq c_j.$$

Parametrization of the matrix of the Hankel operator associated with a G -invariant linear form

Let $\widehat{\mathcal{V}}$ be the representation of a finite group G on $\mathbb{R}[x]$ induced by a representation on \mathbb{R}^n , let Λ be a G -invariant linear form on $\mathbb{R}[x]$ and let $\Lambda^{(\delta)}$ be the restriction of the linear form Λ to $\mathbb{R}[x]_{\leq 2\delta}$ for a certain degree $\delta \in \mathbb{N}$. In an orthogonal symmetry adapted basis $B^{(\delta)}$ of $\mathbb{R}[x]_{\leq \delta}$, the matrix $H_1^{B^{(\delta)}}$ of the Hankel operator associated with $\Lambda^{(\delta)}$ has the block diagonal structure described in Proposition 6.11. In particular, for every $j = 1, \dots, N$, its submatrix in the basis B_j consists of n_j identical blocks: it is therefore sufficient to focus on only one of them, denoted by $H^{(j)}$.

Since Λ is G -invariant, it is determined by its values on $\mathbb{R}[x]^G$, that is (8.2) is satisfied. With the notations of (9.2) and (9.3) and with the help of Reynolds operator π_G , the matrices $H^{(1)}, \dots, H^{(N)}$ are then

- for $1 \leq j \leq M$

$$H^{(j)} = \left(\Lambda(\pi_G(b_{1s}^j b_{1t}^j)) \right)_{1 \leq s, t \leq c_j}, \tag{9.4}$$

- for $M + 1 \leq j \leq N$

$$\begin{aligned} H^{(j)} &= \begin{pmatrix} S_j & -A_j \\ A_j & S_j \end{pmatrix} \\ \text{with } S_j &= \left(\Lambda(\pi_G(a_{1s}^j a_{1t}^j)) \right)_{1 \leq s, t \leq c_j} = \left(\Lambda(\pi_G(b_{1s}^j b_{1t}^j)) \right)_{1 \leq s, t \leq c_j} \\ \text{and } A_j &= \left(\Lambda(\pi_G(a_{1s}^j b_{1t}^j)) \right)_{1 \leq s, t \leq c_j} = - \left(\Lambda(\pi_G(b_{1s}^j a_{1t}^j)) \right)_{1 \leq s, t \leq c_j}. \end{aligned} \tag{9.5}$$

The coefficients of the matrices $H^{(1)}, \dots, H^{(N)}$ are therefore values of Λ at G -invariant homogeneous polynomials of $\mathbb{R}[x]_{\leq 2\delta}^G$. Thus, we first compute the matrices $H^{(1)}, \dots, H^{(N)}$ with only those G -invariant homogeneous polynomials in the following algorithm.

Algorithm 9.4. Symmetric Hankel Blocks

- Input : \triangleright A representation of a finite group G on \mathbb{R}^n .
 \triangleright An orthogonal symmetry adapted basis of the space $\mathbb{R}[x]_{\leq \delta}$
 for a certain degree δ .
- Output : \triangleright Matrices $H^{(1)}, \dots, H^{(N)}$ with:
- $H^{(j)} = \left(\pi_G(b_{1s}^j b_{1t}^j) \right)_{1 \leq s, t \leq c_j}$ if $1 \leq j \leq M$,
 - $H^{(j)} = \begin{pmatrix} S_j & -A_j \\ A_j & S_j \end{pmatrix}$ if $M + 1 \leq j \leq N$
 with $S_j = \left(\pi_G(a_{1s}^j a_{1t}^j) \right)_{1 \leq s, t \leq c_j}$ and $A_j = \left(\pi_G(a_{1s}^j b_{1t}^j) \right)_{1 \leq s, t \leq c_j}$.

Given a degree $d \in \mathbb{N}$, assume furthermore that there is a linear form Ω on $\mathbb{R}[x]$ such that

$$\Lambda(p) = \Omega(p) \quad \forall p \in \mathbb{R}[x]_{\leq d}. \tag{9.6}$$

The coefficients of the matrices $H^{(1)}, \dots, H^{(N)}$ are then either real values determined by (9.6) or the unknown evaluations of the sought Λ at G -invariant homogeneous polynomials of degree between $d + 1$ and 2δ .

Let $\{p_1, \dots, p_t\}$ be a basis of the supplementary of $\mathbb{R}[x]_{\leq d}^G$ in $\mathbb{R}[x]_{\leq 2\delta}^G$. The unknown coefficients of the matrices $H^{(1)}, \dots, H^{(N)}$ can be expressed as linear combinations of parameters h_1, \dots, h_t with

$$h_\ell = \Lambda(p_\ell) \quad \forall \ell = 1, \dots, t.$$

Similarly to Step 3 in Algorithm 5.1, in which we only worked with monomials, all the parameters h_1, \dots, h_t are required to express the unknown entries of $H^{(1)}, \dots, H^{(N)}$. Thus, the number of unknown parameters to be introduced is

$$t = \dim \mathbb{R}[x]_{\leq 2\delta}^G - \dim \mathbb{R}[x]_{\leq d}^G.$$

This is less than in Algorithm 5.1.

Algorithm 9.5. Parametrization Hankel Blocks

- Input : \triangleright Matrices $H^{(1)}, \dots, H^{(N)}$
 whose coefficients are homogeneous polynomials of $\mathbb{R}[x]_{\leq 2\delta}^G$.
 \triangleright A linear form Ω on $\mathbb{R}[x]_{\leq d}$.
- Output : \triangleright A list $[p_1, \dots, p_t]$ of polynomials among the entries of H_1, \dots, H_N
 such that $\{p_1, \dots, p_t\}$ is a basis of a supplementary of $\mathbb{R}[x]_{\leq d}^G$ in $\mathbb{R}[x]_{\leq 2\delta}^G$.
 \triangleright A list $[h_1, \dots, h_t]$ of parameters.
 \triangleright Matrices $\tilde{H}^{(1)}, \dots, \tilde{H}^{(N)}$ obtained
 by applying the linear map $\psi : \mathbb{R}[x]_{\leq 2\delta} \rightarrow \mathbb{R}[h_1, \dots, h_t]$ defined by
- $\psi(p) = \Omega(p)$ if $\deg p \leq d$,
 - $\psi(p_\ell) = h_\ell$ for all $\ell = 1, \dots, t$,
- to the coefficients of the matrices $H^{(1)}, \dots, H^{(N)}$.

9.2 Existence conditions for a G -invariant cubature

The first step of our procedure is described in Algorithm 9.6 [Existence of a G -invariant cubature]. It provides conditions on some parameters such that the expected G -invariant cubature Λ exists. In comparison to Algorithm 5.1, the use of a symmetry adapted basis allows to introduce less parameters (Step 5) and to deal with smaller-sized matrices in input of Algorithm 4.7 (Step 6).

Algorithm 9.6. Existence of a G -invariant cubature

- Input :
- ▷ The degree d of the expected G -invariant cubature.
 - ▷ The values $\Omega(p) = \int p \, d\mu$ for all $p \in \mathbb{R}[x]_{\leq d}^G$.
 - ▷ A representation of the finite group G on \mathbb{R}^n .
 - ▷ The set of irreducible representations of the group G .
 - ▷ The matrix of multiplicities $\Gamma_G = (\gamma_{jk})_{1 \leq j \leq N, 1 \leq k \leq T}$.
 - ▷ Integers m_1, \dots, m_T , where m_k is the number of orbits of type \mathcal{P}_k in the invariant set of nodes.
- Output :
- ▷ A system of equations and inequations that determines the existence for μ of a G -invariant inside cubature Λ of degree d with positive weights.

Notice that the number of nodes r of the expected G -invariant cubature Λ is then

$$r = \sum_{j=1}^M n_j \sum_{k=1}^T \gamma_{jk} m_k + 2 \sum_{j=M+1}^N n_j \sum_{k=1}^T \gamma_{jk} m_k, \quad (9.7)$$

where the dimension of the irreducible representation $\mathcal{V}^{(j)}$ is n_j if $1 \leq j \leq M$ and $2n_j$ if $M+1 \leq j \leq N$.

1. Compute the expected multiplicities $\gamma_1, \dots, \gamma_N$ and the expected ranks r_1, \dots, r_N .

Consider the kernel I_Λ of the Hankel operator associated with the expected cubature Λ and the induced representation \mathcal{V} of the finite group G on the quotient space $\mathbb{R}[x]/I_\Lambda$. The expected multiplicity of every irreducible representation $\mathcal{V}^{(1)}, \dots, \mathcal{V}^{(N)}$ of G in \mathcal{V} is computed from the integers m_1, \dots, m_T and the matrix of multiplicities Γ_G (Corollary 8.6) and is denoted respectively by $\gamma_1, \dots, \gamma_N$

$$\gamma_j = \sum_{k=1}^T \gamma_{jk} m_k. \quad (9.8)$$

Consider the matrix H_1^B of the linear operator \mathcal{H} associated with Λ in an orthogonal symmetry adapted basis B of $\mathbb{R}[x]/I_\Lambda$. Following Theorem 8.3, H_1^B has a block diagonal structure. For every $1 \leq j \leq N$, the size of each identical block associated with the irreducible representation $\mathcal{V}^{(j)}$ is:

$$r_j = \begin{cases} \gamma_j & \text{if } 1 \leq j \leq M \\ 2\gamma_j & \text{if } M+1 \leq j \leq N. \end{cases}$$

2. Verify that the expected multiplicities $\gamma_1, \dots, \gamma_N$ satisfy

$$\gamma_j \geq \underline{c}'_j \quad \forall j = 1, \dots, N, \quad (9.9)$$

where c'_j is the multiplicity of the irreducible representation $\mathcal{V}^{(j)}$ of G in the induced representation on $\mathbb{R}[x]_{\leq \lfloor \frac{d}{2} \rfloor}$.

Since the moments up to order d are known, the matrix of the Hankel operator associated with the sought cubature Λ in a basis of $\mathbb{R}[x]_{\leq \lfloor \frac{d}{2} \rfloor}$ has entries in \mathbb{K} and has full rank (positive definite). Assuming that this basis is orthogonal symmetry adapted, we get the inequalities (9.9).

3. Choose a degree δ such that the following inequalities are satisfied

$$\gamma_j \leq c''_j \quad \forall j = 1, \dots, N, \quad (9.10)$$

where c''_j is the multiplicity of the irreducible representation $\mathcal{V}^{(j)}$ of G in the induced representation on $\mathbb{R}[x]_{\leq \delta-1}$.

Following Corollary 3.15, the cubature Λ exists if and only if its restriction $\Lambda^{(\delta)}$ to $\mathbb{R}[x]_{\leq 2\delta}$ for a certain degree $\delta \in \mathbb{N}$ satisfies the following properties:

- $\Lambda^{(\delta)}$ is a flat extension of its restriction $\Lambda^{(\delta-1)}$ to $\mathbb{R}[x]_{\leq 2\delta-2}$.
- Its associated Hankel operator $\mathcal{H}^{(\delta)}$ is positive semidefinite of rank r .

With the help of Theorem 3.6, this implies that polynomials b_1, \dots, b_r such that $B = \{[b_1], \dots, [b_r]\}$ is a basis of $\mathbb{R}[x]/I_\Lambda$ can be chosen in $\mathbb{R}[x]_{\leq \delta-1}$. Assuming furthermore that B is an orthogonal symmetry adapted basis of $\mathbb{R}[x]/I_\Lambda$, using (9.7) and (9.8), a necessary condition on the degree δ is then given by (9.10).

4. Compute an orthogonal symmetry adapted basis $B^{(\delta)} = [[B_1^{(\delta)}, \dots, B_M^{(\delta)}], [B_{M+1}^{(\delta)}, \dots, B_N^{(\delta)}]]$ of $\mathbb{R}[x]_{\leq \delta}$.

See Algorithm 9.3 [Symmetry Adapted Polynomial Basis] and the paragraph **Symmetry adapted basis**.

5. Construct the distinct blocks $H^{(1)}, \dots, H^{(N)}$.

Consider the matrix $H_1^{B^{(\delta)}}$ of the Hankel operator associated with $\Lambda^{(\delta)}$ in the orthogonal symmetry adapted basis $B^{(\delta)}$ of $\mathbb{R}[x]_{\leq \delta}$. Following Proposition 6.11, $H_1^{B^{(\delta)}}$ has N distinct blocks on its main diagonal. We denote them by $H^{(1)}, \dots, H^{(N)}$.

See Algorithm 9.4 [Symmetric Hankel Blocks] and the paragraph **Parametrization of the matrix of Hankel operators associated with G -invariant linear forms** for more details on the computation of $H^{(1)}, \dots, H^{(N)}$.

6. Parameterize the unknown coefficients of the matrices $H^{(1)}, \dots, H^{(N)}$.

Every coefficient of the matrices $H^{(1)}, \dots, H^{(N)}$ is:

- either a value $\int p d\mu \in \mathbb{K} \subset \mathbb{R}$ if $p \in \mathbb{R}[x]_{\leq d}^G$,
- or a linear combination of unknown parameters h_1, \dots, h_t otherwise.

See Algorithm 9.5 [Parametrization Hankel Blocks] and the paragraph **Parametrization of the matrix of Hankel operators associated with G -invariant linear forms** for more details on the determination of the parameters h_1, \dots, h_t .

Each matrix $H^{(j)}$ has a $c'_j \times c'_j$ principal submatrix whose entries are in \mathbb{K} and that is positive definite, where c'_j is the dimension of the component of $\mathbb{R}[x]_{\leq \lfloor \frac{d}{2} \rfloor}$ associated with the irreducible representation $\mathcal{V}^{(j)}$.

7. Find conditions on the parameters h_1, \dots, h_t , using Algorithm 4.7 [Diagonalization & Positivity with Rank Constraints] on each matrix $H^{(1)}, \dots, H^{(N)}$, such that the linear form $\Lambda^{(\delta)}$ is a flat extension of the linear form $\Lambda^{(\delta-1)}$ and such that the Hankel operator $\mathcal{H}^{(\delta)}$ is positive semidefinite with rank r .

Following Corollary 3.15, those properties on $\mathcal{H}^{(\delta)}$ are sufficient to prove the existence for the measure μ of a cubature of degree d with positive weights. Contrary to Step 4 in Algorithm 5.1 [Existence of a cubature], those properties are verified on the smaller distinct blocks $H^{(1)}, \dots, H^{(N)}$ of $H_1^{B^{(\delta)}}$. Each block $H^{(j)}$, under the conditions on the parameters h_1, \dots, h_t , satisfies then:

- Its $c_j'' \times c_j''$ principal submatrix that corresponds to the restriction of $\mathcal{H}^{(\delta)}$ to $\mathbb{R}[x]_{\leq \delta-1}$ has the same rank r_j as the whole matrix $H^{(j)}$.
- $H^{(j)}$ is positive semidefinite.

Thus, up to permutations of rows and columns, Algorithm 4.7 can be used to determine those conditions. We get $\begin{pmatrix} c_j'' - c_j' \\ r_j - c_j' \end{pmatrix}$ triplets $[P_j, Z_j, E_j]$ for each matrix $H^{(j)}$ if $1 \leq j \leq N$.

Choosing one triplet per matrix $H^{(j)}$, this provides a system of equations (from Z_1, \dots, Z_N) and inequations (from P_1, \dots, P_N) that determines the existence of a cubature.

8. Find conditions such that the Hankel operators $\mathcal{H}_{g_k}^{(\delta)}$ are positive semidefinite for all $k = 1, \dots, s$. (optional)

Following Proposition 3.16, this guarantees that the nodes lie on $\text{supp } \mu$.

See Section 5.2 - **Existence of an inside cubature** for the computations.

At the end of Step 7, Algorithm 9.6 gives a system of equations and inequations that determines the existence for μ of a G -invariant cubature of degree d with positive weights. There is then no guarantee that the nodes lie on the support of μ . This property is provided by Step 8.

Since this last step requires the computation of new matrices (that are generally not block diagonal), we often skip it in practice. The fact that the cubature is an inside cubature is then checked after the computation of the nodes.

9.3 Computation of the weights and the coordinates of the nodes

Assume now that the existence of a G -invariant cubature has been secured with a solution $\bar{h}_1, \dots, \bar{h}_t$ of the polynomial system of equations and inequations output by Algorithm 9.6. Algorithm 9.7 then computes the weights and the coordinates of the nodes of the associated G -invariant cubature.

Algorithm 9.7. Weights & Nodes

- Input :
- ▷ Input of Algorithm 9.6.
 - ▷ An orthogonal symmetry adapted basis of $\mathbb{R}[x]_{< \delta}$ (Step 4 in Algorithm 9.6).
 - ▷ The parameterized distinct blocks $H^{(1)}, \dots, H^{(N)}$ (Step 6 in Algorithm 9.6).
 - ▷ A value $\bar{h}_1, \dots, \bar{h}_t$ for every parameter h_1, \dots, h_t introduced in Algorithm 9.6.
- Output :
- ▷ The coordinates of the nodes ζ_α for all orbits \mathcal{O}_α with $\alpha = 1, \dots, r_1$.
 - ▷ The common weights $\tilde{a}_1, \dots, \tilde{a}_{r_1}$.

1. Take polynomials b_1, \dots, b_r such that $B = \{[b_1], \dots, [b_r]\}$ is an orthogonal symmetry adapted basis of $\mathbb{R}[x]/I_\Lambda$.

Following Remark 4.8 and Theorem 3.6, the use of Algorithm 4.7 (Step 7 in Algorithm 9.6) gives a way to determine a basis B of $\mathbb{R}[x]/I_\Lambda$ by selecting the appropriate polynomials in the orthogonal symmetry adapted basis $B^{(\delta-1)}$ of $\mathbb{R}[x]_{\leq \delta-1}$ with $B^{(\delta-1)} = B^{(\delta)} \cap \mathbb{R}[x]_{\leq \delta-1}$. The set of selected polynomials in each orthogonal symmetry adapted basis $B_j^{(\delta-1)} = B_j^{(\delta)} \cap B^{(\delta-1)}$ is denoted by $B_j = \{b_1^j, \dots, b_{n_j r_j}^j\}$, where r_j is the expected rank computed in Step 1 of Algorithm 9.6.

2. Compute the distinct invertible blocks $H_1^{(1)}, \dots, H_1^{(N)}$ of the matrix H_1^B of the linear operator \mathcal{H} associated with the sought cubature Λ in the orthogonal symmetry adapted basis B of $\mathbb{R}[x]/I_\Lambda$. Using the values \hbar_1, \dots, \hbar_t , those blocks have entries in \mathbb{K} .

Since the orthogonal symmetry adapted basis B of $\mathbb{R}[x]/I_\Lambda$ is obtained from polynomials in $B^{(\delta)}$, the matrices $H_1^{(1)}, \dots, H_1^{(N)}$ are principal submatrices of the blocks $H^{(1)}, \dots, H^{(N)}$ introduced in Step 5 of Algorithm 9.6. We have

$$H_1^{(j)} = \left(\Lambda(\pi_G(b_s^j b_t^j)) \right)_{1 \leq s, t \leq r_j} \quad \forall 1 \leq j \leq N.$$

The entries are either numbers in \mathbb{K} or linear combinations of h_1, \dots, h_t . It is then sufficient to replace the parameters h_1, \dots, h_t by the values \hbar_1, \dots, \hbar_t .

3. Take a separating set $\{p_1, \dots, p_\eta\}$ of G -invariant polynomials.

This means that the polynomial system (9.11), defined below, has a unique solution.

4. Construct the distinct blocks $H_{p_\nu}^{(1)}, \dots, H_{p_\nu}^{(N)}$ for every polynomial p_ν in the separating set of Step 3.

By Theorem 8.3, the matrices $H_{p_\nu}^B$ have the same block diagonal structure as the matrix H_1^B . For every $1 \leq j \leq N$, take the set B_j of polynomials introduced in Step 1 and compute

$$H_{p_\nu}^{(k)} = \left(\Lambda(\pi_G(p_\nu b_s^j b_t^j)) \right)_{1 \leq s, t \leq r_j},$$

where π_G is Reynolds operator.

The coefficients of those matrices are then numbers in \mathbb{K} , or polynomials in h_1, \dots, h_t , or unknowns. This last case appears if there exists $\nu \in \{1, \dots, \eta\}$ such that $\deg p_\nu > 2$. As in Section 5.2 - **Existence of an inside cubature**, those unknown coefficients are then uniquely determined thanks to Algorithm 5.2 with $\kappa \geq 1$ and $2\kappa \geq \deg p_\nu$ for all $\nu = 1, \dots, \eta$. In addition, since we chose values \hbar_1, \dots, \hbar_t , Algorithm 5.2 gives also unique values $\hbar_{t+1}, \dots, \hbar_\tau$ for the additional parameters h_{t+1}, \dots, h_τ .

5. For every $\nu = 1, \dots, \eta$ and every $\alpha = 1, \dots, r_1$, find the value $\lambda_{\nu\alpha}$ of every polynomial p_ν in the separating set of Step 3 on the orbit \mathcal{O}_α .

Consider the generalized eigenvalue problems for every pair of matrices $(H_{p_\nu}^B, H_1^B)$. Following Corollary 3.9, they are the values of the polynomial p_ν on the invariant set of nodes. The latter is a union of r_1 distinct orbits $\mathcal{O}_1 \cup \dots \cup \mathcal{O}_{r_1}$ (Remark 8.7). Since the polynomial p_ν is G -invariant, the values $p_\nu(\zeta_\alpha)$ are the same for the nodes ζ_α . They are therefore denoted by $\lambda_{\nu\alpha}$: one per G -invariant polynomial p_ν and per orbit \mathcal{O}_α .

Moreover, since the matrices $H_{p_\nu}^B$ and H_1^B have the same block diagonal structure, it is here sufficient to consider the generalized eigenvalue problem for the pairs of distinct

blocks $(H_{p_\nu}^{(1)}, H_1^{(1)}), \dots, (H_{p_\nu}^{(N)}, H_1^{(N)})$. The occurrence of a generalized eigenvalue $\lambda_{\nu\alpha}$ for a given pair of blocks is given in Corollary 8.8.

Using Remark 8.9, it is sufficient to consider the generalized eigenvalues of the pairs $(H_{p_\nu}^{(1)}, H_1^{(1)})$. The computation runs then as follows:

- (a) Take a first G -invariant polynomial p_1 in the separating set.
- (b) Compute the r_1 generalized eigenvalues $\lambda_{1\alpha}$ of the pair $(H_{p_1}^{(1)}, H_1^{(1)})$ and their associated generalized eigenvector ω_α . They satisfy

$$H_{p_1}^{(1)}\omega_\alpha = \lambda_{1\alpha}H_1^{(1)}\omega_\alpha.$$

- (c) Compute $H_1^{(1)}\omega_\alpha$ and $H_{p_\nu}^{(1)}\omega_\alpha$ for each other G -invariant polynomial p_ν in the separating set.
- (d) The generalized eigenvalues $\lambda_{\nu\alpha}$ are then obtained as the only values such that

$$H_{p_\nu}^{(1)}\omega_\alpha = \lambda_{\nu\alpha}H_1^{(1)}\omega_\alpha \quad \forall \nu = 2, \dots, \eta.$$

- (e) Create the set of generalized eigenvalues $\{\lambda_{1\alpha}, \dots, \lambda_{\eta\alpha}\}$ associated with the generalized eigenvector ω_α , and therefore with the orbit \mathcal{O}_α .

Notice that it is sometimes more suitable to compute the generalized eigenvalues of other pairs of blocks, especially

- if those blocks are smaller than the blocks $(H_{p_\nu}^{(1)}, H_1^{(1)})$, or
- if those blocks do not contain unknown coefficients (see Step 4) whereas the block $H_{p_\nu}^{(1)}$ does.

6. Solve the polynomial system for every orbit \mathcal{O}_α with $\alpha = 1, \dots, r_1$

$$p_\nu(x) = \lambda_{\nu\alpha} \quad \forall \nu = 1, \dots, \eta \tag{9.11}$$

to get the coordinates of a node ζ_α per orbit. The other nodes in the orbit \mathcal{O}_α are then computed using the group action of G on \mathbb{R}^n .

7. Solve the Vandermonde-like linear system (9.13).

Given a G -invariant polynomial q ,

$$\Lambda(q) = \sum_{\alpha=1}^{r_1} \tilde{a}_\alpha \sum_{\zeta_\alpha \in \mathcal{O}_\alpha} q(\zeta_\alpha) = \sum_{\alpha=1}^{r_1} |\mathcal{O}_\alpha| q(\zeta_\alpha) \tilde{a}_\alpha. \tag{9.12}$$

Taking $B_1 = \{b_1^1, \dots, b_{r_1}^1\} \subset B$ the orthogonal symmetry adapted basis associated with the absolutely irreducible representation $\mathcal{V}^{(1)}$ defined by $\mathcal{V}^{(1)}(g) = 1$ for all $g \in G$, then

$$\begin{pmatrix} b_1^1(\zeta_1) & \cdots & b_1^1(\zeta_{r_1}) \\ \vdots & & \vdots \\ b_{r_1}^1(\zeta_1) & \cdots & b_{r_1}^1(\zeta_{r_1}) \end{pmatrix} \begin{pmatrix} |\mathcal{O}_1| & & \\ & \ddots & \\ & & |\mathcal{O}_{r_1}| \end{pmatrix} \begin{pmatrix} \tilde{a}_1 \\ \vdots \\ \tilde{a}_{r_1} \end{pmatrix} = \begin{pmatrix} \Lambda(b_1^1) \\ \vdots \\ \Lambda(b_{r_1}^1) \end{pmatrix}. \tag{9.13}$$

9.4 $H_2 : 5 - 1$ (Stroud, 1971)

We look for a cubature of degree 5 for the regular hexagon H_2 in the plane \mathbb{R}^2 . It is described in [78] under the name $H_2 : 5 - 1$ and it was examined in Section 5.4. Here, we recover it as the unique D_6 -invariant cubature such that the nodes are organized as: the origin and an orbit whose 6 nodes lie on the symmetry axes that go through the vertices of the hexagon (see Section 7.4.2).

Let H_2 be the regular hexagon whose vertices are given by $(\pm 1, 0), (\pm \frac{1}{2}, \pm \frac{\sqrt{3}}{2})$ (see Figure 5(a)). The dihedral group D_6 of order 12 (see Section 7.4 for a description of D_6) leaves the hexagon H_2 invariant under its classical action on the plane \mathbb{R}^2 . The representation of D_6 on \mathbb{R}^2 is given by the list of matrices

$$\left[\begin{array}{l} \left(\begin{array}{cc} 1 & 0 \\ 0 & 1 \end{array} \right), \left(\begin{array}{cc} \frac{1}{2} & -\frac{\sqrt{3}}{2} \\ \frac{\sqrt{3}}{2} & 1 \end{array} \right), \left(\begin{array}{cc} -\frac{1}{2} & -\frac{\sqrt{3}}{2} \\ \frac{\sqrt{3}}{2} & -\frac{1}{2} \end{array} \right), \left(\begin{array}{cc} -1 & 0 \\ 0 & -1 \end{array} \right), \left(\begin{array}{cc} -\frac{1}{2} & \frac{\sqrt{3}}{2} \\ -\frac{\sqrt{3}}{2} & -\frac{1}{2} \end{array} \right), \left(\begin{array}{cc} \frac{1}{2} & \frac{\sqrt{3}}{2} \\ -\frac{\sqrt{3}}{2} & \frac{1}{2} \end{array} \right), \\ \left(\begin{array}{cc} 1 & 0 \\ 0 & -1 \end{array} \right), \left(\begin{array}{cc} \frac{1}{2} & \frac{\sqrt{3}}{2} \\ \frac{\sqrt{3}}{2} & -\frac{1}{2} \end{array} \right), \left(\begin{array}{cc} -\frac{1}{2} & \frac{\sqrt{3}}{2} \\ \frac{\sqrt{3}}{2} & \frac{1}{2} \end{array} \right), \left(\begin{array}{cc} -1 & 0 \\ 0 & 1 \end{array} \right), \left(\begin{array}{cc} -\frac{1}{2} & -\frac{\sqrt{3}}{2} \\ -\frac{\sqrt{3}}{2} & \frac{1}{2} \end{array} \right), \left(\begin{array}{cc} \frac{1}{2} & -\frac{\sqrt{3}}{2} \\ -\frac{\sqrt{3}}{2} & -\frac{1}{2} \end{array} \right) \end{array} \right].$$

There are 6 irreducible inequivalent representations $\nu^{(1)}, \nu^{(2)}, \nu^{(3)}, \nu^{(4)}, \nu^{(5)}, \nu^{(6)}$ of the group D_6 (see Section 7.4.2). The submatrix of the matrix of multiplicities Γ_{D_6} that corresponds to this group action is (see Section 7.4.2)

$$\Gamma = \begin{pmatrix} 1 & 1 & 1 & 1 \\ 0 & 0 & 0 & 1 \\ 0 & 1 & 0 & 1 \\ 0 & 0 & 1 & 1 \\ 0 & 1 & 1 & 2 \\ 0 & 1 & 1 & 2 \end{pmatrix}.$$

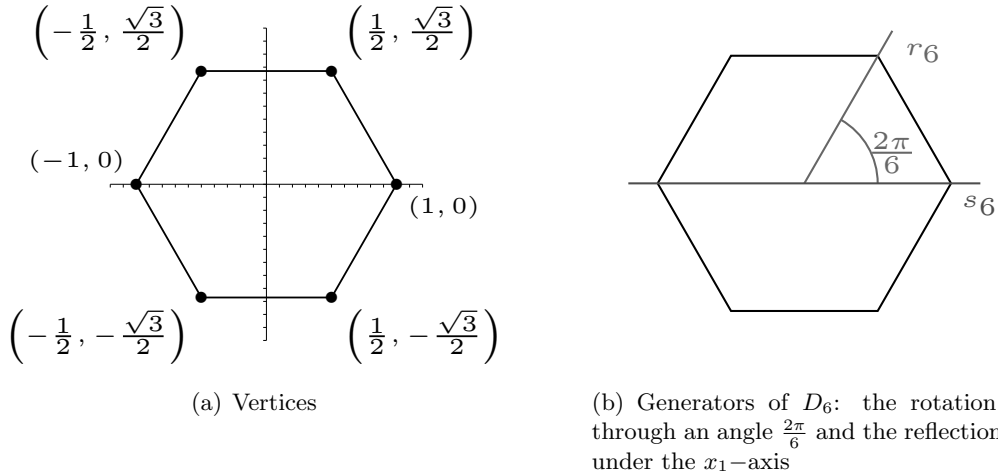

Figure 5: Regular hexagon H_2

Existence conditions

1. Since the two expected orbits are associated with the types of the first and the second column of Γ , the expected multiplicities $\gamma_1, \gamma_2, \gamma_3, \gamma_4, \gamma_5, \gamma_6$ of the irreducible representations $\mathcal{V}^{(1)}, \dots, \mathcal{V}^{(N)}$ of D_6 on $\mathbb{R}[x]/I_\Lambda$ are

$$(\gamma_1, \gamma_2, \gamma_3, \gamma_4, \gamma_5, \gamma_6) = (2, 0, 1, 0, 1, 1), \text{ i.e. } \begin{pmatrix} \gamma_1 \\ \vdots \\ \gamma_6 \end{pmatrix} = \Gamma \begin{pmatrix} 1 \\ 1 \\ 0 \\ 0 \end{pmatrix}.$$

Since all irreducible representations of D_6 are absolutely irreducible, the expected multiplicities γ_j are the expected ranks r_j .

2. The inequalities (9.9) are satisfied since the multiplicities of the irreducible representations $\mathcal{V}^{(1)}, \mathcal{V}^{(2)}, \mathcal{V}^{(3)}, \mathcal{V}^{(4)}, \mathcal{V}^{(5)}, \mathcal{V}^{(6)}$ of D_6 in the restriction of the representation $\widehat{\mathcal{V}}$ to $\mathbb{R}[x]_{\leq 2}$ are

$$(\underline{c}'_1, \underline{c}'_2, \underline{c}'_3, \underline{c}'_4, \underline{c}'_5, \underline{c}'_6) = (2, 0, 0, 0, 1, 1).$$

3. The inequalities (9.10) are satisfied by choosing $\delta = 4$ since the multiplicities of the irreducible representations $\mathcal{V}^{(1)}, \mathcal{V}^{(2)}, \mathcal{V}^{(3)}, \mathcal{V}^{(4)}, \mathcal{V}^{(5)}, \mathcal{V}^{(6)}$ of D_6 in the restriction of the representation $\widehat{\mathcal{V}}$ to $\mathbb{R}[x]_{\leq 3}$ are

$$(\underline{c}''_1, \underline{c}''_2, \underline{c}''_3, \underline{c}''_4, \underline{c}''_5, \underline{c}''_6) = (2, 0, 1, 1, 2, 1).$$

4. An orthogonal symmetry adapted basis of $\mathbb{R}[x]_{\leq 4}$ is

$$\begin{bmatrix} [[1, x_1^2 + x_2^2, x_1^4 + 2x_1^2x_2^2 + x_2^4], []], [[x_1^3 - 3x_1x_2^2], [x_1^2x_2 - \frac{1}{3}x_2^3]], \\ [[x_1, x_1^3 + x_1x_2^2], [x_2, x_1^2x_2 + x_2^3]], \\ [[x_1^2 - x_2^2, x_1^4 - x_2^4, x_1^2x_2^2 - \frac{1}{3}x_2^4], [2x_1x_2, 2x_1^3x_2 + 2x_1x_2^3, x_1^3x_2 - \frac{1}{3}x_1x_2^3]] \end{bmatrix}.$$

5. The distinct blocks $H^{(1)}, H^{(2)}, H^{(3)}, H^{(4)}, H^{(5)}, H^{(6)}$ are then computed.
6. After the parametrization, the distinct blocks $H^{(1)}, H^{(2)}, H^{(3)}, H^{(4)}, H^{(5)}, H^{(6)}$ are

$$\begin{pmatrix} \frac{3\sqrt{3}}{2} & \frac{5\sqrt{3}}{8} & \frac{7\sqrt{3}}{20} \\ \frac{5\sqrt{3}}{8} & \frac{7\sqrt{3}}{20} & \mathbf{h}_1 + 6\mathbf{h}_2 \\ \frac{7\sqrt{3}}{20} & \mathbf{h}_1 + 6\mathbf{h}_2 & \mathbf{h}_4 \end{pmatrix}, \quad (), \quad (\mathbf{h}_1), \quad \left(\frac{2}{3}\mathbf{h}_2\right), \\ \begin{pmatrix} \frac{5\sqrt{3}}{16} & \frac{7\sqrt{3}}{40} \\ \frac{7\sqrt{3}}{40} & \frac{1}{2}\mathbf{h}_1 + 3\mathbf{h}_2 \end{pmatrix}, \quad \begin{pmatrix} \frac{7\sqrt{3}}{40} & \frac{1}{2}\mathbf{h}_1 + 3\mathbf{h}_2 & \mathbf{h}_2 \\ \frac{1}{2}\mathbf{h}_1 + 3\mathbf{h}_2 & \frac{1}{2}\mathbf{h}_4 & \mathbf{h}_3 \\ \mathbf{h}_2 & \mathbf{h}_3 & \frac{1}{3}\mathbf{h}_3 \end{pmatrix}.$$

7. The parameters h_1, h_2, h_3, h_4 are determined using Algorithm 4.7 on each block. There is only one possible set of values for the parameters

$$\hbar_1 = \frac{49\sqrt{3}}{250}, \hbar_2 = 0, \hbar_3 = 0, \hbar_4 = \frac{343\sqrt{3}}{3125}$$

such that the linear form $\Lambda^{(4)}$ is a flat extension of the linear form $\Lambda^{(3)}$ and such that the Hankel operator $\mathcal{H}^{(4)}$ is positive semidefinite with rank 7.

Thus, there exists for the hexagon H_2 a single D_6 -invariant cubature of degree 5 with positive weights and with this organization of nodes in orbit types.

We do not prove here that the nodes lie on the hexagon H_2 . This is shown *a posteriori* once the coordinates of the nodes are computed.

Computation of the weights and the nodes

The computation of the coordinates of the nodes is based on the knowledge obtained from the organization of the nodes in orbit types (see Figure 6(a)). Indeed, the only missing information is the radius ρ of the circle where the nodes lie on, except the origin (see Figure 6(b)). This is obtained as the square root of the evaluation of the D_6 -invariant polynomial $p = x_1^2 + x_2^2$ at any node on this circle.

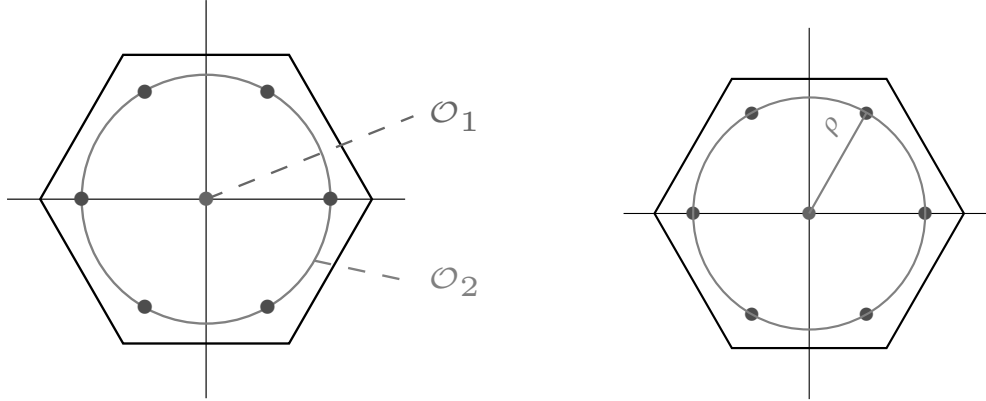

(a) Expected organization of the nodes in orbits: \mathcal{O}_1 the origin and \mathcal{O}_2 an orbit with 6 nodes

(b) The coordinates of the nodes are determined by the radius ρ with $\rho^2 = \frac{14}{15}$

Figure 6: Nodes of the cubature

1. An orthogonal symmetry adapted basis B of $\mathbb{R}[x]/I_\Lambda$ is given by the selected polynomials

$$\begin{bmatrix} [[1, x_1^2 + x_2^2]], [[]], [[x_1^3 - 3x_1x_2^2]], [[]], \\ [[x_1], [x_2]], \\ [[x_1^2 - x_2^2], [2x_1x_2]] \end{bmatrix}$$

2. The distinct invertible blocks $H_1^{(1)}, H_1^{(2)}, H_1^{(3)}, H_1^{(4)}, H_1^{(5)}, H_1^{(6)}$ with the values $\hbar_1, \hbar_2, \hbar_3, \hbar_4$ are

$$\begin{pmatrix} \frac{3\sqrt{3}}{2} & \frac{5\sqrt{3}}{8} \\ \frac{5\sqrt{3}}{8} & \frac{7\sqrt{3}}{20} \end{pmatrix}, (), \left(\frac{49\sqrt{3}}{250}\right), (), \left(\frac{5\sqrt{3}}{16}\right), \left(\frac{7\sqrt{3}}{40}\right).$$

3. The separating set contains only one D_6 -invariant polynomial

$$p = x_1^2 + x_2^2.$$

4. The distinct blocks $H_p^{(1)}, H_p^{(2)}, H_p^{(3)}, H_p^{(4)}, H_p^{(5)}, H_p^{(6)}$ are

$$\begin{pmatrix} \frac{5\sqrt{3}}{8} & \frac{7\sqrt{3}}{20} \\ \frac{7\sqrt{3}}{20} & \frac{49\sqrt{3}}{250} \end{pmatrix}, (), \left(\frac{343\sqrt{3}}{3125}\right), (), \left(\frac{7\sqrt{3}}{40}\right), \left(\frac{49\sqrt{3}}{500}\right).$$

In this case, there is no additional unknown coefficients.

5. Instead of computing the generalized eigenvalues for the pair of 2×2 blocks $(H_p^{(1)}, H_1^{(1)})$, we can compute here the one of any other pair of 1×1 blocks $(H_p^{(j)}, H_1^{(j)})$ with $j \in \{3, 5, 6\}$. The generalized eigenvalue problem is thus reduced to a single division.

For instance, if we take the fifth blocks, the generalized eigenvalue, that is the evaluation of the polynomial p at any node (except the origin), is given by

$$\frac{7}{40}\sqrt{3} \div \frac{5}{16}\sqrt{3} = \frac{14}{25}.$$

If we would have solved the generalized eigenvalue problem for the pair of 2×2 blocks $(H_p^{(1)}, H_1^{(1)})$, we would get the evaluations of the polynomial p at the distinct orbits, that is 0 since the origin is an orbit and $\frac{14}{25}$ the one that corresponds to ρ^2 .

6. The polynomial system for the orbit with 6 nodes is here reduced to a single equation

$$x_1^2 + x_2^2 = \frac{14}{25}.$$

Since it is here sufficient to know the radius ρ , it is even reduced to the computation of the square root of the computed generalized eigenvalue. The coordinates of the nodes are then the following (see Figure 6(b))

$$(0, 0), \left(\frac{\sqrt{14}}{5}, 0\right), \left(\frac{\sqrt{14}}{10}, \frac{\sqrt{42}}{10}\right), \left(-\frac{\sqrt{14}}{10}, \frac{\sqrt{42}}{10}\right), \left(-\frac{\sqrt{14}}{5}, 0\right), \left(-\frac{\sqrt{14}}{10}, -\frac{\sqrt{42}}{10}\right), \left(\frac{\sqrt{14}}{10}, -\frac{\sqrt{42}}{10}\right).$$

7. The computation of the weights is reduced to the Vandermonde-like linear system (9.13) with a 2×2 matrix

$$\begin{pmatrix} 1 & 6 \\ 0 & \frac{84}{25} \end{pmatrix} \begin{pmatrix} \check{a}_1 \\ \check{a}_2 \end{pmatrix} = \begin{pmatrix} \frac{3\sqrt{3}}{2} \\ \frac{5\sqrt{3}}{8} \end{pmatrix}$$

and the distinct weights are

$$\check{a}_1 = \frac{43\sqrt{3}}{112}, \check{a}_2 = \frac{125\sqrt{3}}{672}.$$

The expected D_6 -invariant inside cubature with positive weights of degree 5 for the hexagon H_2 is then determined thanks to Table 1.

	Type (number of nodes)	Weight	A node per orbit
\mathcal{O}_1	\mathcal{P}_1 (1)	$\frac{43\sqrt{3}}{112}$	(0,0)
\mathcal{O}_2	\mathcal{P}_2 (6)	$\frac{125\sqrt{3}}{672}$	$\left(\frac{\sqrt{14}}{5}, 0\right)$

Table 1: Weights and nodes of the cubature

10 D_6 -invariant cubatures of degree 13 for the regular hexagon

In this section, we detail how to search for inside D_6 -invariant cubatures for the regular hexagon H_2 with positive weights. In [35, Section 6 - Rotational-symmetric formulas], the author looked for cubatures whose nodes are union of orbits with 1 node or 6 nodes. With the inequalities (9.9), we explain why it is impossible to find an inside D_6 -invariant cubature of degree bigger than 11 with positive weights and without an orbit with 12 nodes. We prove then that there exist D_6 -invariant cubatures of degree 13 using Algorithm 9.6 [Existence of a G -invariant cubature] and that there is no such cubature with less than 37 nodes. We conclude with the construction of cubatures with 37 nodes using Algorithm 9.7.

10.1 Existence of cubatures with at least 37 nodes

We first introduce the input of Algorithm 9.6 [Existence of a G -invariant cubature] and discuss the different possible organizations of the nodes of the sought cubatures in orbit types. Applying Algorithm 9.6, we show that only three organizations provide cubatures.

In this search, we are looking for D_6 -invariant cubatures of degree 13 for the regular hexagon H_2 : $(\pm 1, 0)$, $(\pm \frac{1}{2}, \pm \frac{\sqrt{3}}{2})$. The moments for H_2 of order less than or equal to 13 are computed thanks to the formulas in [76]. Any value $\int p d\mu$ with $p \in \mathbb{R}[x]_{\leq 13}^G$ is then a linear combination of those moments.

Taking $m = 6$ in Section 7.4, we get:

- ▷ A representation \mathcal{W} of D_6 on \mathbb{R}^2 deduced from the action of D_6 that leaves H_2 invariant.

$$\left[\begin{array}{l} \left(\begin{array}{cc} 1 & 0 \\ 0 & 1 \end{array} \right), \left(\begin{array}{cc} \frac{1}{2} & -\frac{\sqrt{3}}{2} \\ \frac{\sqrt{3}}{2} & 1 \end{array} \right), \left(\begin{array}{cc} -\frac{1}{2} & -\frac{\sqrt{3}}{2} \\ \frac{\sqrt{3}}{2} & -\frac{1}{2} \end{array} \right), \left(\begin{array}{cc} -1 & 0 \\ 0 & -1 \end{array} \right), \left(\begin{array}{cc} -\frac{1}{2} & \frac{\sqrt{3}}{2} \\ -\frac{\sqrt{3}}{2} & -\frac{1}{2} \end{array} \right), \left(\begin{array}{cc} \frac{1}{2} & \frac{\sqrt{3}}{2} \\ -\frac{\sqrt{3}}{2} & \frac{1}{2} \end{array} \right), \\ \left(\begin{array}{cc} 1 & 0 \\ 0 & -1 \end{array} \right), \left(\begin{array}{cc} \frac{1}{2} & \frac{\sqrt{3}}{2} \\ \frac{\sqrt{3}}{2} & -\frac{1}{2} \end{array} \right), \left(\begin{array}{cc} -\frac{1}{2} & \frac{\sqrt{3}}{2} \\ \frac{\sqrt{3}}{2} & \frac{1}{2} \end{array} \right), \left(\begin{array}{cc} -1 & 0 \\ 0 & 1 \end{array} \right), \left(\begin{array}{cc} -\frac{1}{2} & -\frac{\sqrt{3}}{2} \\ -\frac{\sqrt{3}}{2} & \frac{1}{2} \end{array} \right), \left(\begin{array}{cc} \frac{1}{2} & -\frac{\sqrt{3}}{2} \\ -\frac{\sqrt{3}}{2} & -\frac{1}{2} \end{array} \right) \end{array} \right].$$

- ▷ The set $[L_{abs}, L_{com}]$ of irreducible representations $\nu^{(1)}, \nu^{(2)}, \nu^{(3)}, \nu^{(4)}, \nu^{(5)}, \nu^{(6)}$. Since they are all absolutely irreducible, L_{com} is empty and L_{abs} is

$$\left[\begin{array}{l} [1, 1, 1, 1, 1, 1, 1, 1, 1, 1, 1, 1] \\ [1, 1, 1, 1, 1, 1, -1, -1, -1, -1, -1, -1] \\ [1, -1, 1, -1, 1, -1, 1, -1, 1, -1, 1, -1] \\ [1, -1, 1, -1, 1, -1, -1, 1, -1, 1, -1, 1] \\ \left[\begin{array}{l} \left(\begin{array}{cc} 1 & 0 \\ 0 & 1 \end{array} \right), \left(\begin{array}{cc} \frac{1}{2} & -\frac{\sqrt{3}}{2} \\ \frac{\sqrt{3}}{2} & \frac{1}{2} \end{array} \right), \left(\begin{array}{cc} -\frac{1}{2} & -\frac{\sqrt{3}}{2} \\ \frac{\sqrt{3}}{2} & -\frac{1}{2} \end{array} \right), \left(\begin{array}{cc} -1 & 0 \\ 0 & -1 \end{array} \right), \left(\begin{array}{cc} -\frac{1}{2} & \frac{\sqrt{3}}{2} \\ -\frac{\sqrt{3}}{2} & -\frac{1}{2} \end{array} \right), \left(\begin{array}{cc} \frac{1}{2} & \frac{\sqrt{3}}{2} \\ -\frac{\sqrt{3}}{2} & \frac{1}{2} \end{array} \right), \\ \left(\begin{array}{cc} 1 & 0 \\ 0 & -1 \end{array} \right), \left(\begin{array}{cc} \frac{1}{2} & \frac{\sqrt{3}}{2} \\ \frac{\sqrt{3}}{2} & -\frac{1}{2} \end{array} \right), \left(\begin{array}{cc} -\frac{1}{2} & \frac{\sqrt{3}}{2} \\ \frac{\sqrt{3}}{2} & \frac{1}{2} \end{array} \right), \left(\begin{array}{cc} -1 & 0 \\ 0 & 1 \end{array} \right), \left(\begin{array}{cc} -\frac{1}{2} & -\frac{\sqrt{3}}{2} \\ -\frac{\sqrt{3}}{2} & \frac{1}{2} \end{array} \right), \left(\begin{array}{cc} \frac{1}{2} & -\frac{\sqrt{3}}{2} \\ -\frac{\sqrt{3}}{2} & -\frac{1}{2} \end{array} \right) \end{array} \right] \\ \left[\begin{array}{l} \left(\begin{array}{cc} 1 & 0 \\ 0 & 1 \end{array} \right), \left(\begin{array}{cc} -\frac{1}{2} & -\frac{\sqrt{3}}{2} \\ \frac{\sqrt{3}}{2} & -\frac{1}{2} \end{array} \right), \left(\begin{array}{cc} -\frac{1}{2} & \frac{\sqrt{3}}{2} \\ -\frac{\sqrt{3}}{2} & -\frac{1}{2} \end{array} \right), \left(\begin{array}{cc} 1 & 0 \\ 0 & 1 \end{array} \right), \left(\begin{array}{cc} -\frac{1}{2} & -\frac{\sqrt{3}}{2} \\ \frac{\sqrt{3}}{2} & -\frac{1}{2} \end{array} \right), \left(\begin{array}{cc} -\frac{1}{2} & \frac{\sqrt{3}}{2} \\ -\frac{\sqrt{3}}{2} & -\frac{1}{2} \end{array} \right), \\ \left(\begin{array}{cc} 1 & 0 \\ 0 & -1 \end{array} \right), \left(\begin{array}{cc} -\frac{1}{2} & \frac{\sqrt{3}}{2} \\ \frac{\sqrt{3}}{2} & \frac{1}{2} \end{array} \right), \left(\begin{array}{cc} -\frac{1}{2} & -\frac{\sqrt{3}}{2} \\ -\frac{\sqrt{3}}{2} & \frac{1}{2} \end{array} \right), \left(\begin{array}{cc} 1 & 0 \\ 0 & -1 \end{array} \right), \left(\begin{array}{cc} -\frac{1}{2} & \frac{\sqrt{3}}{2} \\ \frac{\sqrt{3}}{2} & \frac{1}{2} \end{array} \right), \left(\begin{array}{cc} -\frac{1}{2} & -\frac{\sqrt{3}}{2} \\ -\frac{\sqrt{3}}{2} & -\frac{1}{2} \end{array} \right) \end{array} \right] \end{array} \right]$$

- ▷ The matrix of multiplicities Γ_{D_6} , and more precisely the submatrix corresponding to this group action

$$\Gamma = \begin{pmatrix} 1 & 1 & 1 & 1 \\ 0 & 0 & 0 & 1 \\ 0 & 1 & 0 & 1 \\ 0 & 0 & 1 & 1 \\ 0 & 1 & 1 & 2 \\ 0 & 1 & 1 & 2 \end{pmatrix}.$$

The different possibilities for the integers (m_1, m_2, m_3, m_4) are now discussed, where:

- $m_1 = 1$ if the origin is a node and $m_1 = 0$ otherwise.
- m_2 is the number of orbits with 6 nodes such that 2 nodes lie on the x_1 -axis.
- m_3 is the number of orbits with 6 nodes such that 2 nodes lie on the x_2 -axis.
- m_4 is the number of orbits with 12 nodes.

They satisfy

$$r = m_1 + 6(m_2 + m_3) + 12m_4,$$

where r is the number of nodes. The solutions of this equation over the nonnegative integers are given in Table 2. Only the cases $r = 31$, $r = 36$ and $r = 37$ are considered since

- $r = 31$ corresponds to Möller's lower bound (2.10).
- $m_1 \in \{0, 1\}$ so that $r \equiv 0 \pmod{6}$ or $r \equiv 1 \pmod{6}$. The cases $r = 32$, $r = 33$, $r = 34$ and $r = 35$ are therefore impossible.
- We shall show that there is no cubature with less than 37 nodes.

31 nodes	(1, 5, 0, 0), (1, 4, 1, 0), (1, 3, 2, 0), (1, 2, 3, 0), (1, 1, 4, 0), (1, 0, 5, 0) (1, 3, 0, 1), (1, 2, 1, 1), (1, 1, 2, 1), (1, 0, 3, 1), (1, 1, 0, 2), (1, 0, 1, 2)
36 nodes	(0, 6, 0, 0), (0, 5, 1, 0), (0, 4, 2, 0), (0, 3, 3, 0), (0, 2, 4, 0), (0, 1, 5, 0), (0, 0, 6, 0) (0, 4, 0, 1), (0, 3, 1, 1), (0, 2, 2, 1), (0, 1, 3, 1), (0, 0, 4, 1), (0, 2, 0, 2), (0, 1, 1, 2), (0, 0, 2, 2)
37 nodes	(1, 6, 0, 0), (1, 5, 1, 0), (1, 4, 2, 0), (1, 3, 3, 0), (1, 2, 4, 0), (1, 1, 5, 0), (1, 0, 6, 0) (1, 4, 0, 1), (1, 3, 1, 1), (1, 2, 2, 1), (1, 1, 3, 1), (1, 0, 4, 1), (1, 2, 0, 2), (1, 1, 1, 2), (1, 0, 2, 2)

Table 2: Possible values for the integers (m_1, m_2, m_3, m_4)

The number of possible cases in Table 2 can be reduced thanks to the inequalities (9.9) in Step 2 of Algorithm 9.6. The expected multiplicities $\gamma_1, \gamma_2, \gamma_3, \gamma_4, \gamma_5, \gamma_6$ are linked to the integers m_1, m_2, m_3, m_4 thanks to (8.5) by

$$\gamma_1 = m_1 + m_2 + m_3 + m_4, \quad \gamma_2 = m_4, \quad \gamma_3 = m_2 + m_4, \quad \gamma_4 = m_3 + m_4,$$

$$\gamma_5 = m_2 + m_3 + 2m_4, \quad \gamma_6 = m_2 + m_3 + 2m_4.$$

Here $\lfloor \frac{d}{2} \rfloor = 6$ and the multiplicities $\underline{c}'_1, \underline{c}'_2, \underline{c}'_3, \underline{c}'_4, \underline{c}'_5, \underline{c}'_6$ are

$$(\underline{c}'_1, \underline{c}'_2, \underline{c}'_3, \underline{c}'_4, \underline{c}'_5, \underline{c}'_6) = (5, 1, 2, 2, 4, 5).$$

According to (9.9),

$$\gamma_j \geq \underline{c}'_j \quad \forall j = 1, \dots, 6,$$

thus:

- Since $\gamma_2 = m_4$ and $\underline{c}'_2 = 1$, (9.9) implies that there is at least 1 orbit with 12 nodes. The cases with $m_4 = 0$ are therefore impossible.

This explains why no inside cubature of degree 13 with positive weights can be found in [35]. A D_6 -invariant cubature of degree bigger than 13 has at least 1 orbit with 12 nodes.

- Since $\underline{c}'_1 = 5$ and $\gamma_1 = m_1 + m_2 + m_3 + m_4$ (Remark 8.7), (9.9) implies that there are at least 5 orbits. The cases with $m_4 = 2$ for 31 nodes and 36 nodes in Table 2 are therefore impossible.
- Since $\underline{c}'_3 = \underline{c}'_4 = 2$, $\gamma_3 = m_2 + m_4$ and $\gamma_4 = m_3 + m_4$, (9.9) allows us to discard the cases in Table 2 with $m_2 = 0$ and $m_4 = 1$ or with $m_3 = 0$ and $m_4 = 1$.

The remaining cases are then the ones in bold in Table 2.

With the help of Algorithm 9.6 (until Step 7), we find the systems of equations and inequalities that determine the existence for H_2 of D_6 -invariant cubatures of degree 13 with positive weights². The only cases for which there exist such cubatures are in Table 3. The choice of the degree δ (Step 3) and the corresponding values of $(c''_1, c''_2, c''_3, c''_4, c''_5, c''_6)$ and $(c_1, c_2, c_3, c_4, c_5, c_6)$ are indicated. Notice that the irreducible representations of D_6 are absolutely irreducible so that

$$\gamma_j = r_j, \quad \underline{c}'_j = c'_j, \quad \underline{c}''_j = c''_j \quad \forall j = 1, \dots, 6.$$

37 nodes	δ	$(c''_1, c''_2, c''_3, c''_4, c''_5, c''_6)$	$(c_1, c_2, c_3, c_4, c_5, c_6)$
Case (1,3,1,1)	10	(7, 2, 5, 5, 10, 8)	(9, 3, 5, 5, 10, 12)
Case (1,2,2,1)	9	(7, 2, 3, 3, 7, 8)	(7, 2, 5, 5, 10, 8)
Case (1,1,3,1)	10	(7, 2, 5, 5, 10, 8)	(9, 3, 5, 5, 10, 12)

Table 3: Values for the integers (m_1, m_2, m_3, m_4) such that cubatures exist

The last column informs us on the size of the matrices we deal with in this symmetric approach. In comparison, if symmetry were not taken into account as in Section 5, the size of the matrices would have been: $\dim \mathbb{R}[x]_{\leq 10} = 66$ in the cases (1,3,1,1) and (1,1,3,1) and $\dim \mathbb{R}[x]_{\leq 9} = 55$ in the case (1,2,2,1).

The systems of the cases (1,3,1,1) and (1,1,3,1) have both a unique solution, whereas the systems of the case (1,2,1,1) have two solutions.

²Due to the size of the matrices, we do not give here the details of the computations.

10.2 Computation of the weights and the nodes of the 4 cubatures

With the help of the 4 solutions found thanks to Algorithm 9.6 [Existence of a G -invariant cubature], we are now able to compute the 4 associated cubatures using Algorithm 9.7 [Weights & Nodes]. We first need to determine a separating set $\{p_1, \dots, p_\eta\}$ of G -invariant polynomials and then choose if it is preferable to solve the generalized eigenvalues for the pairs of blocks $(H_{p_\nu}^{(1)}, H_1^{(1)})$ or for other blocks (as in the example of Section 9.4). Both depend on the organization of nodes in orbit types (see Figures 7(a), 8(a), 9(a) and 10(a)).

Thanks to the values of the integers (m_1, m_2, m_3, m_4) in those cases (Table 3), we know that:

- The origin is a node: this orbit is denoted by \mathcal{O}_1 .
- There are 4 orbits $\mathcal{O}_2, \mathcal{O}_3, \mathcal{O}_4$ and \mathcal{O}_5 with 6 nodes (see Figures 7(b), 8(b), 9(b) and 10(b)): the missing information is the radii ρ_2, ρ_3, ρ_4 and ρ_5 of the circles where the nodes lie on. They are obtained thanks to the D_6 -invariant polynomial $p_1 = x_1^2 + x_2^2$.
- There is 1 orbit \mathcal{O}_6 with 12 nodes (see Figures 7(c), 8(c), 9(c) and 10(c)). For this orbit, knowing the radius ρ_6 is not enough. The additional required information is the angle θ_6 of one of the node on \mathcal{O}_6 . We choose the unique node such that $0 < \theta_6 < \frac{\pi}{6}$. It is possible to compute it thanks to a second D_6 -invariant polynomial given in [32, Chapter XII.4] by

$$p_2 = (x_1 + ix_2)^6 + (x_1 - ix_2)^6 = 2x_1^6 - 30x_1^4x_2^2 + 30x_1^2x_2^4 - 2x_2^6.$$

Indeed, assuming the evaluation $p_2(\zeta_6)$ of p_2 at any node ζ_6 on \mathcal{O}_6 is known, θ_6 is then the unique solution of the equation in θ

$$p_2(\zeta_6) = 2\rho_6^6 \cos(6\theta) \tag{10.1}$$

under the constraint $0 < \theta < \frac{\pi}{6}$.

The separating set in Step 3 of Algorithm 9.7 is then

$$\{p_1, p_2\} = \{x_1^2 + x_2^2, 2x_1^6 - 30x_1^4x_2^2 + 30x_1^2x_2^4 - 2x_2^6\}.$$

As noticed in Step 5 of Algorithm 9.7, it is sometimes more suitable to take other blocks than the first blocks. We choose here to consider the second, third and fourth blocks. This corresponds to the choice of a 3×3 unimodular submatrix of Γ . Indeed, since the first column of Γ informs on the presence of the origin as a node and since we already have this information, a 4×4 unimodular submatrix of Γ is not required to solve uniquely the linear systems (8.6).

The strategy for Steps 5 and 6 of Algorithm 9.7 is then the following:

1. Compute the generalized eigenvalues of $(H_{p_1}^{(2)}, H_1^{(2)})$, $(H_{p_1}^{(3)}, H_1^{(3)})$ and $(H_{p_1}^{(4)}, H_1^{(4)})$. The unique generalized eigenvalue of the pair $(H_{p_1}^{(2)}, H_1^{(2)})$ is ρ_6^2 . It is also a generalized eigenvalue of the pairs $(H_{p_1}^{(3)}, H_1^{(3)})$ and $(H_{p_1}^{(4)}, H_1^{(4)})$. The other generalized eigenvalues are ρ_2^2 , ρ_3^2 , ρ_4^2 and ρ_5^2 . This determines the orbits $\mathcal{O}_2, \mathcal{O}_3, \mathcal{O}_4$ and \mathcal{O}_5 .
2. Compute the generalized eigenvalue of the pair $(H_{p_2}^{(2)}, H_1^{(2)})$. Solving (10.1), we get then θ_6 . This determines the orbit \mathcal{O}_6 .

This strategy has the following advantages:

- The second, third and fourth blocks are smaller than the first ones since

$$\gamma_1 = m_1 + m_2 + m_3 + m_4 = 6$$

whereas

$$\gamma_2 = m_4 = 1, \quad \gamma_3 = m_2 + m_4 \leq 4, \quad \gamma_4 = m_3 + m_4 \leq 4.$$

- The matrix $H_{p_2}^{(1)}$ contains coefficients that have not been determined yet, whereas the blocks $H_{p_1}^{(2)}, H_{p_1}^{(3)}, H_{p_1}^{(4)}, H_{p_2}^{(2)}$ do not.

Case 37 nodes (1,3,1,1)

Among the different triplets $[P, Z, E]$ output by Algorithm 9.6, only one triplet has a solution. This is checked by computing a Groebner basis of the polynomials in each set Z : if it is reduced to $\{1\}$, then there is no solution. Solving the polynomial system obtained from this set Z , we get 2 distinct sets of values for the 14 unknown parameters in the blocks $H^{(1)}, \dots, H^{(6)}$ introduced in Step 6 of Algorithm 9.6. But only 1 of these distinct sets of values satisfies the positivity constraints from P . Using this remaining set of values, we apply Algorithm 9.7.

1. An orthogonal symmetry adapted basis of the second, third and fourth component of $\mathbb{R}[x]/I_\Lambda$ is given by selecting the following polynomials in the second, third and fourth component of $\mathbb{R}[x]_{\leq 9}$

$$\begin{aligned} & [x_1^5 x_2 - \frac{10}{3} x_1^3 x_2^3 + x_1 x_2^5], \\ & [x_1^3 - 3x_1 x_2^2, x_1^5 - 2x_1^3 x_2^2 - 3x_1 x_2^4, x_1^7 - x_1^5 x_2^2 - 5x_1^3 x_2^4 - 3x_1 x_2^6, x_1^9 - 6x_1^5 x_2^4 - 8x_1^3 x_2^6 - 3x_1 x_2^8], \\ & [x_1^2 x_2 - \frac{1}{3} x_2^3, x_1^4 x_2 + \frac{2}{3} x_1^2 x_2^3 - \frac{1}{3} x_2^5]. \end{aligned}$$

2. The invertible blocks $H_1^{(2)}, H_1^{(3)}$ and $H_1^{(4)}$ are respectively

$$\begin{pmatrix} \frac{309\sqrt{3}}{2240} & \frac{1661\sqrt{3}}{16800} & \frac{2743\sqrt{3}}{36960} & \frac{32289\sqrt{3}}{560560} \\ \frac{1661\sqrt{3}}{16800} & \frac{2743\sqrt{3}}{36960} & \frac{32289\sqrt{3}}{560560} & \hbar_1 \\ \frac{2743\sqrt{3}}{36960} & \frac{32289\sqrt{3}}{560560} & \hbar_1 & \hbar_2 \\ \frac{32289\sqrt{3}}{560560} & \hbar_1 & \hbar_2 & \hbar_3 \end{pmatrix}, \begin{pmatrix} \frac{3\sqrt{3}}{320} & \frac{33\sqrt{3}}{5600} \\ \frac{33\sqrt{3}}{5600} & \frac{13\sqrt{3}}{3360} \end{pmatrix}$$

with

- $\hbar_1 = \frac{a_1}{b_1} \sqrt{3} + \frac{c_1}{d_1} \sqrt{17144267591348974794021990}$, where $a_1 = 19\ 186\ 284\ 158\ 106\ 782\ 360\ 533\ 739\ 463\ 657\ 337\ 817\ 123\ 801$, $b_1 = 418\ 401\ 904\ 389\ 034\ 302\ 548\ 727\ 436\ 218\ 159\ 228\ 313\ 795\ 248$, $c_1 = 5\ 567\ 090\ 272\ 441\ 677\ 908\ 851\ 774\ 900\ 194\ 238\ 557$, $d_1 = 841\ 929\ 568\ 618\ 188\ 155\ 306\ 432\ 227\ 859\ 273\ 914\ 412\ 831\ 615\ 499\ 878\ 072$;
- $\hbar_2 = \frac{a_2}{b_2} \sqrt{3} + \frac{c_2}{d_2} \sqrt{17144267591348974794021990}$, where $a_2 = 100\ 644\ 786\ 976\ 659\ 682\ 070\ 463\ 039\ 891\ 774\ 035\ 345\ 240\ 805\ 103\ 944\ 907\ 979\ 378\ 573\ 344\ 459\ 912\ 746\ 782\ 918\ 911$, $b_2 = 2\ 704\ 980\ 476\ 033\ 486\ 556\ 489\ 785\ 064\ 780\ 349\ 140\ 562\ 806\ 614\ 191\ 813\ 930\ 605\ 564\ 527\ 233\ 948\ 504\ 807\ 144\ 477\ 272$, $c_2 = 2\ 692\ 747\ 051\ 260\ 847\ 118\ 697\ 851\ 888\ 062\ 234\ 830\ 635\ 134\ 922\ 176\ 183\ 333\ 837\ 316\ 013\ 944\ 129\ 422\ 605$, $d_2 = 111\ 083\ 655\ 886\ 817\ 745\ 301\ 726\ 914\ 106\ 003\ 422\ 756\ 088\ 032\ 763\ 135\ 997\ 877\ 992\ 203\ 328\ 157\ 474\ 585\ 305\ 760\ 353\ 810\ 740\ 892$;

- $\hbar_3 = \frac{a_3}{b_3}\sqrt{3} + \frac{c_3}{d_3}\sqrt{17144267591348974794021990}$, where $a_3 = 7\ 283\ 689\ 389\ 530\ 020\ 687\ 327\ 879\ 287\ 363\ 947\ 837\ 479\ 130\ 940\ 966\ 369\ 197\ 834\ 056\ 038\ 784\ 443\ 739\ 447\ 843\ 426\ 948\ 705\ 675\ 601\ 589\ 918\ 194\ 245\ 146\ 220\ 917\ 649\ 105$, $b_3 = 237\ 928\ 944\ 478\ 830\ 793\ 763\ 337\ 210\ 016\ 263\ 094\ 342\ 851\ 319\ 049\ 025\ 571\ 460\ 275\ 675\ 526\ 275\ 599\ 800\ 626\ 064\ 134\ 483\ 668\ 500\ 122\ 886\ 339\ 856\ 563\ 412\ 032\ 025\ 094\ 728$, $c_3 = 1\ 241\ 436\ 209\ 175\ 718\ 349\ 395\ 214\ 969\ 806\ 564\ 819\ 809\ 454\ 926\ 485\ 085\ 828\ 176\ 115\ 515\ 396\ 204\ 763\ 573\ 238\ 272\ 305\ 862\ 722\ 038\ 062\ 295\ 489\ 152\ 070\ 911\ 905$, $d_3 = 23\ 675\ 573\ 565\ 914\ 340\ 619\ 610\ 870\ 129\ 744\ 084\ 654\ 082\ 590\ 667\ 785\ 100\ 505\ 000\ 310\ 812\ 665\ 988\ 891\ 402\ 293\ 048\ 479\ 659\ 862\ 166\ 950\ 222\ 395\ 055\ 486\ 727\ 951\ 870\ 690\ 172\ 583\ 454$.

3. The separating set is

$$\{p_1, p_2\} = \{x_1^2 + x_2^2, 2x_1^6 - 30x_1^4x_2^2 + 30x_1^2x_2^4 - 2x_2^6\}.$$

4. The distinct blocks $H_{p_1}^{(2)}$, $H_{p_1}^{(3)}$, $H_{p_1}^{(4)}$ and $H_{p_2}^{(2)}$ are respectively

$$(\hbar_4), \begin{pmatrix} \frac{1661\sqrt{3}}{16800} & \frac{2743\sqrt{3}}{36960} & \frac{32289\sqrt{3}}{560560} & \hbar_1 \\ \frac{2743\sqrt{3}}{36960} & \frac{32289\sqrt{3}}{560560} & \hbar_1 & \hbar_2 \\ \frac{32289\sqrt{3}}{560560} & \hbar_1 & \hbar_2 & \hbar_3 \\ \hbar_1 & \hbar_2 & \hbar_3 & \hbar_5 \end{pmatrix}, \begin{pmatrix} \frac{33\sqrt{3}}{5600} & \frac{13\sqrt{3}}{3360} \\ \frac{13\sqrt{3}}{3360} & \frac{113\sqrt{3}}{43120} \end{pmatrix}, (\hbar_6)$$

with

- $\hbar_4 = \frac{a_4}{b_4}\sqrt{3} + \frac{c_4}{d_4}\sqrt{17144267591348974794021990}$, where $a_4 = 9\ 455$, $b_4 = 18\ 403\ 616$, $c_4 = 31$, $d_4 = 571\ 361\ 519\ 791\ 841\ 856$;
- $\hbar_5 = \frac{a_5}{b_5}\sqrt{3} + \frac{c_5}{d_5}\sqrt{17144267591348974794021990}$, where $a_5 = 255\ 046\ 343\ 368\ 657\ 902\ 032\ 035\ 810\ 584\ 989\ 396\ 180\ 758\ 522\ 278\ 323\ 088\ 786\ 814\ 384\ 588\ 121\ 792\ 142\ 231\ 366\ 698\ 352\ 182\ 106\ 512\ 356\ 391\ 354\ 154\ 109\ 916\ 513\ 250\ 420\ 859\ 737\ 118\ 041\ 674\ 388\ 085\ 063\ 549\ 809\ 716\ 817\ 197\ 395$, $b_5 = 20\ 504\ 879\ 343\ 462\ 084\ 258\ 987\ 829\ 821\ 461\ 719\ 328\ 722\ 616\ 605\ 023\ 822\ 361\ 842\ 992\ 680\ 724\ 544\ 792\ 997\ 979\ 674\ 389\ 719\ 434\ 382\ 521\ 396\ 555\ 528\ 421\ 509\ 283\ 704\ 410\ 354\ 725\ 643\ 019\ 794\ 602\ 699\ 099\ 189\ 322\ 392\ 194\ 883\ 907\ 072$, $c_5 = 4\ 576\ 894\ 285\ 553\ 975\ 518\ 305\ 535\ 223\ 630\ 459\ 761\ 168\ 220\ 718\ 266\ 886\ 005\ 032\ 577\ 650\ 137\ 651\ 108\ 792\ 249\ 894\ 623\ 688\ 027\ 596\ 430\ 503\ 882\ 513\ 971\ 127\ 137\ 510\ 545\ 693\ 051\ 677\ 164\ 647\ 182\ 982\ 585\ 772\ 352\ 668\ 925$, $d_5 = 35\ 085\ 850\ 298\ 044\ 533\ 172\ 867\ 654\ 356\ 342\ 901\ 088\ 780\ 624\ 369\ 783\ 916\ 703\ 845\ 920\ 672\ 391\ 742\ 891\ 346\ 291\ 148\ 336\ 384\ 113\ 426\ 888\ 123\ 568\ 677\ 963\ 230\ 440\ 693\ 759\ 232\ 902\ 912\ 809\ 977\ 532\ 342\ 648\ 595\ 129\ 944\ 742\ 775\ 149\ 349\ 759\ 008$;
- $\hbar_6 = \frac{a_6}{b_6}\sqrt{3} + \frac{c_6}{d_6}\sqrt{17144267591348974794021990}$, where $a_6 = 77\ 781\ 325$, $b_6 = 187\ 074\ 235\ 502$, $c_6 = 355\ 858\ 765$, $d_6 = 1\ 463\ 599\ 811\ 939\ 162\ 046\ 290\ 064$.

The computation is now done in floating point arithmetic.

5. The generalized eigenvalue of the pair $(H_{p_1}^{(2)}, H_1^{(2)})$ is

$$\rho_6^2 = 0.7160263383987789.$$

The generalized eigenvalues of the pair $(H_{p_1}^{(3)}, H_1^{(3)})$, distinct from ρ_6^2 , are

$$\rho_2^2 = 0.5402717232537627, \rho_3^2 = 0.1688260881819940, \rho_4^2 = 0.8696140693752899.$$

The generalized eigenvalue of the pair $(H_{p_1}^{(4)}, H_1^{(4)})$, distinct from ρ_6^2 , is

$$\rho_5^2 = 0.4273663513856634.$$

The generalized eigenvalue of the pair $(H_{p_2}^{(2)}, H_1^{(2)})$ is

$$2\rho_6^6 \cos(6\theta_6) = -0.1841200190295809.$$

6. We first deduce the coordinates of a node per orbit (Table 4) from the equations above and then the coordinates of the whole set of nodes from the group action and the orbit type (see Figure 7(a)).
7. The solutions of the Vandermonde-like linear system (9.13) are the distinct weights (Table 4).

A D_6 -invariant cubature of degree 13 for the hexagon H_2 is thus determined (Table 4).

	Type (number of nodes)	Common weight \check{a}_α	A node ζ_α per orbit \mathcal{O}_α
\mathcal{O}_1	\mathcal{P}_1 (1)	0.1581420400555712	(0,0)
\mathcal{O}_2	\mathcal{P}_2 (6)	0.0784240699308296	(0.7350317838391498,0)
\mathcal{O}_3	\mathcal{P}_2 (6)	0.1344412904126819	(0.4108845192776117,0)
\mathcal{O}_4	\mathcal{P}_2 (6)	0.0252992190340063	(0.9325310018306576,0)
\mathcal{O}_5	\mathcal{P}_3 (6)	0.0945409138972820	(0,0.6537326298921168)
\mathcal{O}_6	\mathcal{P}_4 (12)	0.0369751009707455	(0.8073714597089485,0.2533331096525298)

Table 4: Weights and nodes of the cubature in the case (1,3,1,1)

Case 37 nodes (1,2,2,1)

Among the different triplets $[P, Z, E]$ output by Algorithm 9.6, only one triplet has a solution. This is checked by computing a Groebner basis of the polynomials in each set Z : if it is reduced to $\{1\}$, then there is no solution. Solving the polynomial system obtained from this set Z , we get 4 distinct sets of values ³ for the 10 unknown parameters in the blocks $H^{(1)}, \dots, H^{(6)}$ introduced in Step 6 of Algorithm 9.6. But only 2 of these distinct sets of values satisfy the positivity constraints from P . Using this remaining set of values, we apply Algorithm 9.7.

1. An orthogonal symmetry adapted basis of the second, third and fourth component of $\mathbb{R}[x]/I_\Lambda$ is given by selecting the following polynomials in the second, third and fourth component of $\mathbb{R}[x]_{\leq 8}$

$$\begin{aligned}
& [x_1^5 x_2 - \frac{10}{3} x_1^3 x_2^3 + x_1 x_2^5], \\
& [x_1^3 - 3x_1 x_2^2, x_1^5 - 2x_1^3 x_2^2 - 3x_1 x_2^4, x_1^7 - x_1^5 x_2^2 - 5x_1^3 x_2^4 - 3x_1 x_2^6], \\
& [x_1^2 x_2 - \frac{1}{3} x_2^3, x_1^4 x_2 + \frac{2}{3} x_1^2 x_2^3 - \frac{1}{3} x_2^5, x_1^6 x_2 + \frac{5}{3} x_1^4 x_2^3 + \frac{1}{3} x_1^2 x_2^5 - \frac{1}{3} x_2^7].
\end{aligned}$$

2. The invertible blocks $H_1^{(2)}$, $H_1^{(3)}$ and $H_1^{(4)}$ are respectively

$$\begin{pmatrix} \frac{31\sqrt{3}}{34496} \end{pmatrix}, \begin{pmatrix} \frac{309\sqrt{3}}{2240} & \frac{1661\sqrt{3}}{16800} & \frac{2743\sqrt{3}}{36960} \\ \frac{1661\sqrt{3}}{16800} & \frac{2743\sqrt{3}}{36960} & \frac{32289\sqrt{3}}{560560} \\ \frac{2743\sqrt{3}}{36960} & \frac{32289\sqrt{3}}{560560} & \check{h}_1 \end{pmatrix}, \begin{pmatrix} \frac{3\sqrt{3}}{320} & \frac{33\sqrt{3}}{5600} & \frac{13\sqrt{3}}{3360} \\ \frac{33\sqrt{3}}{5600} & \frac{13\sqrt{3}}{3360} & \frac{113\sqrt{3}}{43120} \\ \frac{13\sqrt{3}}{3360} & \frac{113\sqrt{3}}{43120} & \check{h}_2 \end{pmatrix}.$$

Since the exact value of \check{h}_1 and \check{h}_2 is too large to appear here, we give here an approximation

$$\begin{aligned}
\text{First solution:} & \quad \check{h}_1 = 0.0792022183895574, \quad \check{h}_2 = 0.0031602798204254. \\
\text{Second solution:} & \quad \check{h}_1 = 0.0792484380582109, \quad \check{h}_2 = 0.0031582155999142.
\end{aligned}$$

³In fact, 8 distinct sets of values, but 4 are in $\mathbb{C} \setminus \mathbb{R}$.

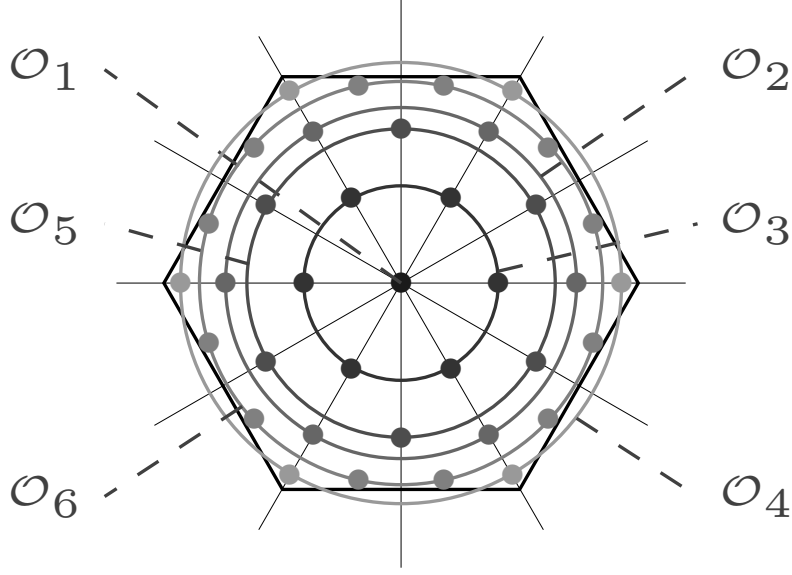

(a) Organization of the nodes in orbits: \mathcal{O}_1 the origin, \mathcal{O}_2 , \mathcal{O}_3 and \mathcal{O}_4 the orbits with 6 nodes and 2 nodes on the x_1 -axis, \mathcal{O}_5 the orbit with 6 nodes and 2 nodes on the x_2 -axis and \mathcal{O}_6 the orbit with 12 nodes

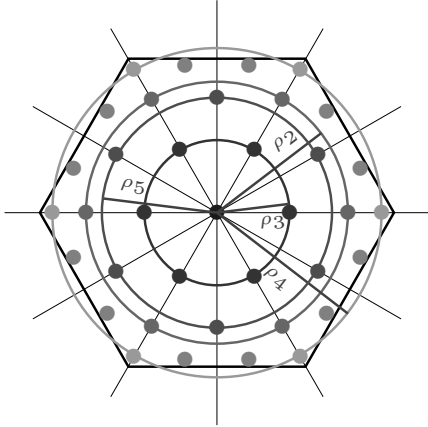

(b) The coordinates of the nodes in \mathcal{O}_2 , \mathcal{O}_3 , \mathcal{O}_4 and \mathcal{O}_5 are determined by the radii ρ_2 , ρ_3 , ρ_4 and ρ_5

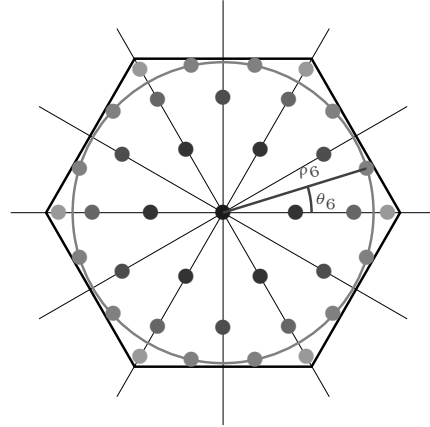

(c) The coordinates of the nodes in \mathcal{O}_6 are determined by the radius ρ_6 and the angle θ_6

Figure 7: Nodes of the cubature in the case (1,3,1,1)

3. The separating set is

$$\{p_1, p_2\} = \{x_1^2 + x_2^2, 2x_1^6 - 30x_1^4x_2^2 + 30x_1^2x_2^4 - 2x_2^6\}.$$

4. The distinct blocks $H_{p_1}^{(2)}$, $H_{p_1}^{(3)}$, $H_{p_1}^{(4)}$ and $H_{p_2}^{(2)}$ are respectively

$$(\tilde{h}_3), \begin{pmatrix} \frac{1661\sqrt{3}}{16800} & \frac{2743\sqrt{3}}{36960} & \frac{32289\sqrt{3}}{560560} \\ \frac{2743\sqrt{3}}{36960} & \frac{32289\sqrt{3}}{560560} & \tilde{h}_1 \\ \frac{32289\sqrt{3}}{560560} & \tilde{h}_1 & \tilde{h}_4 \end{pmatrix}, \begin{pmatrix} \frac{33\sqrt{3}}{5600} & \frac{13\sqrt{3}}{3360} & \frac{113\sqrt{3}}{43120} \\ \frac{13\sqrt{3}}{3360} & \frac{113\sqrt{3}}{43120} & \tilde{h}_2 \\ \frac{113\sqrt{3}}{43120} & \tilde{h}_2 & \tilde{h}_5 \end{pmatrix}, (\tilde{h}_6).$$

Since the exact value of \hbar_3 , \hbar_4 , \hbar_5 and \hbar_6 is too large to appear here, we give here an approximation

$$\begin{aligned} \text{First solution: } & \hbar_3 = 0.0012635157417496, \quad \hbar_4 = 0.0638006574002314, \\ & \hbar_5 = 0.0022579544688321, \quad \hbar_6 = 0.0006922999031606. \\ \text{Second solution: } & \hbar_3 = 0.0012892840704738, \quad \hbar_4 = 0.0639268521092782, \\ & \hbar_5 = 0.0022540005061904, \quad \hbar_6 = 0.0012137720826728. \end{aligned}$$

The computation is now done in floating point arithmetic.

5. The generalized eigenvalue of the pair $(H_{p_1}^{(2)}, H_1^{(2)})$ is

$$\begin{aligned} \text{First solution: } & \rho_6^2 = 0.8117589301751710. \\ \text{Second solution: } & \rho_6^2 = 0.8283140630210464. \end{aligned}$$

The generalized eigenvalues of the pair $(H_{p_1}^{(3)}, H_1^{(3)})$, distinct from ρ_6^2 , are

$$\begin{aligned} \text{First solution: } & \rho_2^2 = 0.4895274642961736, \quad \rho_3^2 = 0.8373579271553270. \\ \text{Second solution: } & \rho_2^2 = 0.5060570527375981, \quad \rho_3^2 = 0.1247012858056488. \end{aligned}$$

The generalized eigenvalues of the pair $(H_{p_1}^{(4)}, H_1^{(4)})$, distinct from ρ_6^2 , is

$$\begin{aligned} \text{First solution: } & \rho_4^2 = 0.5884676559118877, \quad \rho_5^2 = 0.1876538077028625. \\ \text{Second solution: } & \rho_4^2 = 0.2412793258525374, \quad \rho_5^2 = 0.6068420380215161. \end{aligned}$$

The generalized eigenvalue of the pair $(H_{p_2}^{(2)}, H_1^{(2)})$ is

$$\begin{aligned} \text{First solution: } & 2\rho_6^6 \cos(6\theta_6) = 0.4447753282217330. \\ \text{Second solution: } & 2\rho_6^6 \cos(6\theta_6) = 0.7798005950781460. \end{aligned}$$

6. We first deduce the coordinates of a node per orbit (Tables 5 and 6) from the equalities above and then the coordinates of the whole set of nodes from the group action and the orbit type (see Figures 8(a) and 9(a)).
7. The solutions of the Vandermonde-like linear system (9.13) are the distinct weights (Tables 5 and 6).

D_6 -invariant cubatures of degree 13 for the hexagon H_2 are thus determined (Tables 5 and 6).

	Type (number of nodes)	Common weight \check{a}_α	A node ζ_α per orbit \mathcal{O}_α
\mathcal{O}_1	\mathcal{P}_1 (1)	0.1743980715348907	(0,0)
\mathcal{O}_2	\mathcal{P}_2 (6)	0.1083603943222180	(0.6996623930786290,0)
\mathcal{O}_3	\mathcal{P}_2 (6)	0.0207256103020582	(0.9150726337802696,0)
\mathcal{O}_4	\mathcal{P}_3 (6)	0.0843685971535321	(0,0.7671164552592022)
\mathcal{O}_5	\mathcal{P}_3 (6)	0.1510318603712617	(0,0.4331902673476431)
\mathcal{O}_6	\mathcal{P}_4 (12)	0.0197299472436671	(0.8847052130152165,0.1704570803272869)

Table 5: Weights and nodes of the cubature in the case (1,2,2,1): first solution

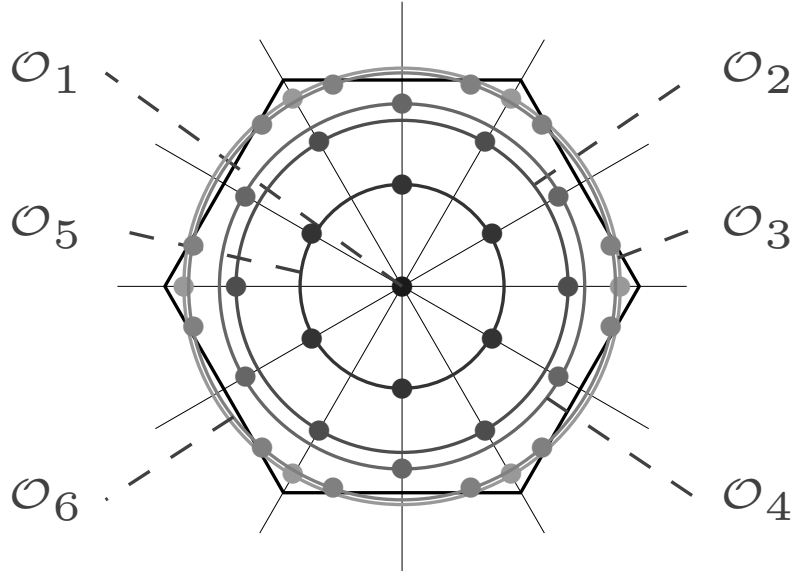

(a) Organization of the nodes in orbits: \mathcal{O}_1 the origin, \mathcal{O}_2 and \mathcal{O}_3 the orbits with 6 nodes and 2 nodes on the x_1 -axis, \mathcal{O}_4 and \mathcal{O}_5 the orbits with 6 nodes and 2 nodes on the x_2 -axis and \mathcal{O}_6 the orbit with 12 nodes

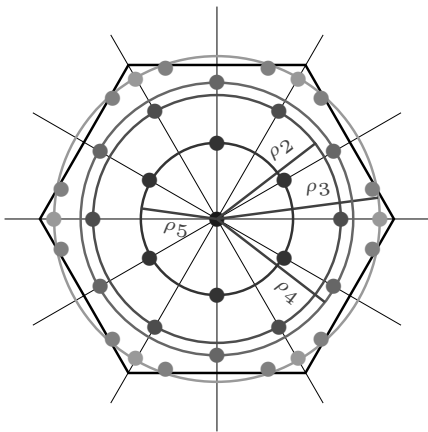

(b) The coordinates of the nodes in \mathcal{O}_2 , \mathcal{O}_3 , \mathcal{O}_4 and \mathcal{O}_5 are determined by the radii ρ_2 , ρ_3 , ρ_4 and ρ_5

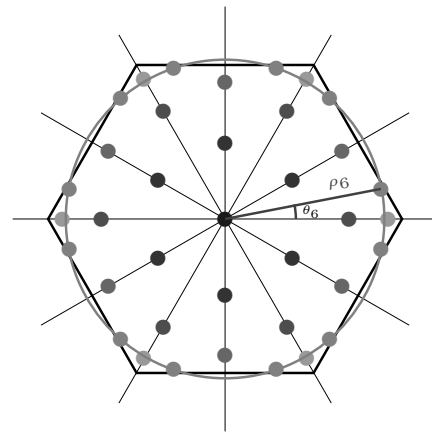

(c) The coordinates of the nodes in \mathcal{O}_6 are determined by the radius ρ_6 and the angle θ_6

Figure 8: Nodes of the cubature in the case (1,2,2,1): first solution

	Type (number of nodes)	Common weight \check{a}_α	A node ζ_α per orbit \mathcal{O}_α
\mathcal{O}_1	\mathcal{P}_1 (1)	0.1492131124137626	(0,0)
\mathcal{O}_2	\mathcal{P}_2 (6)	0.1043930407971358	(0.7113768710890690,0)
\mathcal{O}_3	\mathcal{P}_2 (6)	0.0615527088469823	(0.3531306917173286,0)
\mathcal{O}_4	\mathcal{P}_3 (6)	0.1071155341363768	(0,0.4912019196316788)
\mathcal{O}_5	\mathcal{P}_3 (6)	0.0804531873973581	(0,0.7790006662549782)
\mathcal{O}_6	\mathcal{P}_4 (12)	0.0273146893227030	(0.9017400519011072,0.1232028482491464)

Table 6: Weights and nodes of the cubature in the case (1,2,2,1): second solution

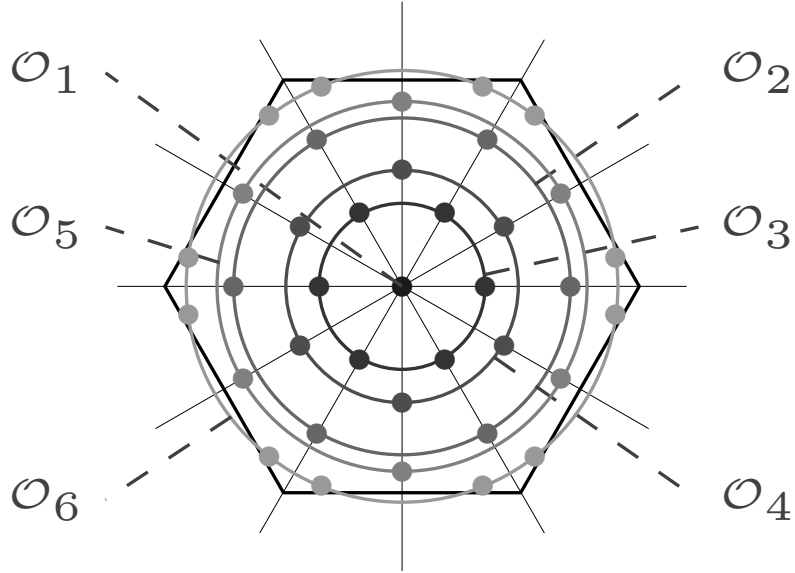

(a) Organization of the nodes in orbits: \mathcal{O}_1 the origin, \mathcal{O}_2 and \mathcal{O}_3 the orbits with 6 nodes and 2 nodes on the x_1 -axis, \mathcal{O}_4 and \mathcal{O}_5 the orbits with 6 nodes and 2 nodes on the x_2 -axis and \mathcal{O}_6 the orbit with 12 nodes

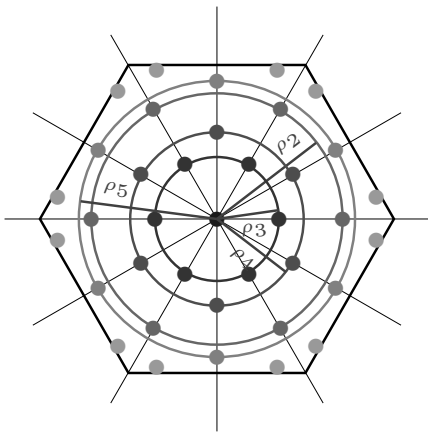

(b) The coordinates of the nodes in \mathcal{O}_2 , \mathcal{O}_3 , \mathcal{O}_4 and \mathcal{O}_5 are determined by the radii ρ_2 , ρ_3 , ρ_4 and ρ_5

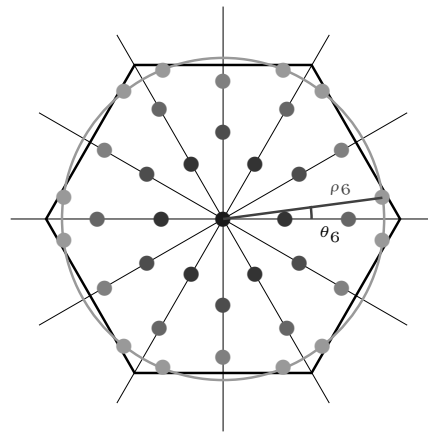

(c) The coordinates of the nodes in \mathcal{O}_6 are determined by the radius ρ_6 and the angle θ_6

Figure 9: Nodes of the cubature in the case (1,2,2,1): second solution

Case 37 nodes (1,1,3,1)

Among the different triplets $[P, Z, E]$ output by Algorithm 9.6, only one triplet has a solution. This is checked by computing a Groebner basis of the polynomials in each set Z : if it is reduced to $\{1\}$, then there is no solution. Solving the polynomial system obtained from this set Z , we get 2 distinct sets of values for the 14 unknown parameters in the blocks $H^{(1)}, \dots, H^{(6)}$ introduced in Step 6 of Algorithm 9.6. But only 1 of these distinct sets of values satisfies the positivity constraints from P . Using this remaining set of values, we apply Algorithm 9.7.

1. An orthogonal symmetry adapted basis of the second, third and fourth component of $\mathbb{R}[x]/I_\Lambda$ is given by selecting the following polynomials in the second, third and fourth component of $\mathbb{R}[x]_{\leq 9}$

$$\begin{aligned} & [x_1^5 x_2 - \frac{10}{3} x_1^3 x_2^3 + x_1 x_2^5], \\ & [x_1^3 - 3x_1 x_2^2, x_1^5 - 2x_1^3 x_2^2 - 3x_1 x_2^4], \\ & [x_1^2 x_2 - \frac{1}{3} x_2^3, x_1^4 x_2 + \frac{2}{3} x_1^2 x_2^3 - \frac{1}{3} x_2^5, x_1^6 x_2 + \frac{5}{3} x_1^4 x_2^3 + \frac{1}{3} x_1^2 x_2^5 - \frac{1}{3} x_2^7, x_1^8 x_2 + \frac{14}{3} x_1^4 x_2^5 - \frac{8}{9} x_1^2 x_2^7 - \frac{19}{81} x_2^9]. \end{aligned}$$

2. The invertible blocks $H_1^{(2)}$, $H_1^{(3)}$ and $H_1^{(4)}$ are respectively

$$\begin{pmatrix} \frac{31\sqrt{3}}{34496} \end{pmatrix}, \begin{pmatrix} \frac{309\sqrt{3}}{2240} & \frac{1661\sqrt{3}}{16800} \\ \frac{1661\sqrt{3}}{16800} & \frac{2743\sqrt{3}}{36960} \end{pmatrix}, \begin{pmatrix} \frac{3\sqrt{3}}{320} & \frac{33\sqrt{3}}{5600} & \frac{13\sqrt{3}}{3360} & \frac{13\sqrt{3}}{6160} \\ \frac{33\sqrt{3}}{5600} & \frac{13\sqrt{3}}{3360} & \frac{113\sqrt{3}}{43120} & \frac{152\hbar_1}{27} + \hbar_2 \\ \frac{13\sqrt{3}}{3360} & \frac{113\sqrt{3}}{43120} & 8\hbar_1 + \hbar_2 & \hbar_3 \\ \frac{13\sqrt{3}}{6160} & \frac{152\hbar_1}{27} + \hbar_2 & \hbar_3 & \hbar_4 \end{pmatrix}.$$

Since the exact values of \hbar_1 , \hbar_2 , \hbar_3 and \hbar_4 are too large to appear here, we give here an approximation

$$\hbar_1 = 0.0002347083678754, \hbar_2 = 0.0012829189683071,$$

$$\hbar_3 = 0.0019029768903960, \hbar_4 = 0.0012473869646381.$$

3. The separating set is

$$\{p_1, p_2\} = \{x_1^2 + x_2^2, 2x_1^6 - 30x_1^4 x_2^2 + 30x_1^2 x_2^4 - 2x_2^6\}.$$

4. The distinct blocks $H_{p_1}^{(2)}$, $H_{p_1}^{(3)}$, $H_{p_1}^{(4)}$ and $H_{p_2}^{(2)}$ are respectively

$$(\hbar_2), \begin{pmatrix} \frac{1661\sqrt{3}}{16800} & \frac{2743\sqrt{3}}{36960} \\ \frac{2743\sqrt{3}}{36960} & \frac{32289\sqrt{3}}{560560} \end{pmatrix}, \begin{pmatrix} \frac{33\sqrt{3}}{5600} & \frac{13\sqrt{3}}{3360} & \frac{113\sqrt{3}}{43120} & \frac{152}{27}\hbar_1 + \hbar_2 \\ \frac{13\sqrt{3}}{3360} & \frac{113\sqrt{3}}{43120} & 8\hbar_1 + \hbar_2 & \hbar_3 \\ \frac{113\sqrt{3}}{43120} & 8\hbar_1 + \hbar_2 & \hbar_3 & \hbar_5 \\ \frac{152}{27}\hbar_1 + \hbar_2 & \hbar_3 & \hbar_5 & \hbar_6 \end{pmatrix}, (\hbar_7).$$

Since the exact values of \hbar_5 , \hbar_6 and \hbar_7 are too large to appear here, we give here an approximation

$$\hbar_5 = 0.0014224327872072, \hbar_6 = 0.0009661526368457, \hbar_7 = 0.0012045336983775.$$

The computation is now done in floating point arithmetic.

5. The generalized eigenvalue of the pair $(H_{p_1}^{(2)}, H_1^{(2)})$ is

$$\rho_6^2 = 0.8242247364265768.$$

The generalized eigenvalues of the pair $(H_{p_1}^{(3)}, H_1^{(3)})$, distinct from ρ_6^2 , is

$$\rho_2^2 = 0.4905623338439775.$$

The generalized eigenvalues of the pair $(H_{p_1}^{(4)}, H_1^{(4)})$, distinct from ρ_6^2 , are

$$\rho_3^2 = 0.5855752916340393, \rho_4^2 = 0.1877507115737364, \rho_5^2 = 0.7139224749993048.$$

The generalized eigenvalue of the pair $(H_{p_2}^{(2)}, H_1^{(2)})$ is

$$2\rho_6^6 \cos(6\theta_6) = 0.7738652982675917.$$

6. We first deduce the coordinates of a node per orbit (Table 7) from the equalities above and then the coordinates of the whole set of nodes from the group action and the orbit type (see Figure 10(a)).
7. The solutions of the Vandermonde-like linear system (9.13) are the distinct weights (Table 7).

A D_6 -invariant cubature of degree 13 for the hexagon H_2 is thus determined (Table 7).

	Type (number of nodes)	Common weight \check{a}_α	A node ζ_α per orbit \mathcal{O}_α
\mathcal{O}_1	\mathcal{P}_1 (1)	0.1744622899297936	(0,0)
\mathcal{O}_2	\mathcal{P}_2 (6)	0.1086813753508295	(0.7004015518572025,0)
\mathcal{O}_3	\mathcal{P}_3 (6)	0.0813509550506738	(0,0.7652289145308346)
\mathcal{O}_4	\mathcal{P}_3 (6)	0.1511466131316961	(0,0.4333021019724418)
\mathcal{O}_5	\mathcal{P}_3 (6)	0.0057447253848289	(0,0.8449393321412519)
\mathcal{O}_6	\mathcal{P}_4 (12)	0.0285059923262794	(0.8996509650134044,0.1218723823391791)

Table 7: Weights and nodes of the cubature in the case (1,1,3,1)

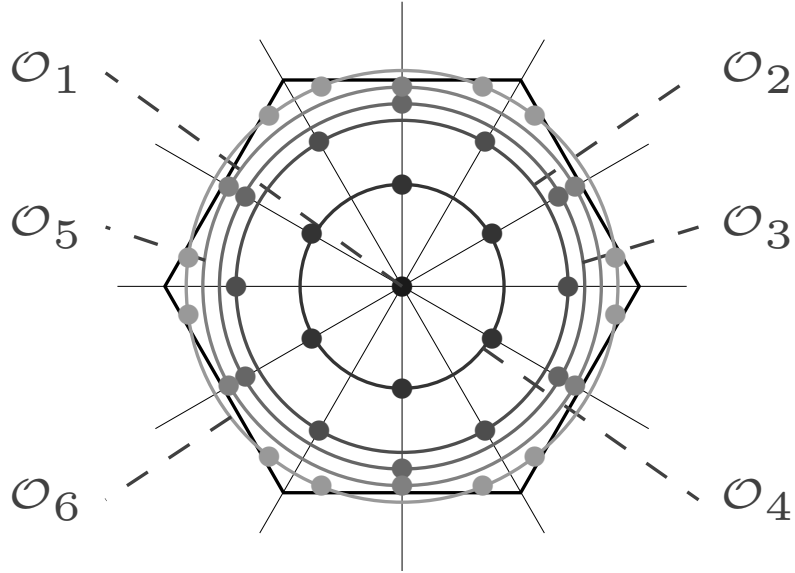

(a) Organization of the nodes in orbits: \mathcal{O}_1 the origin, \mathcal{O}_2 the orbit with 6 nodes and 2 nodes on the x_1 -axis, \mathcal{O}_3 , \mathcal{O}_4 and \mathcal{O}_5 the orbits with 6 nodes and 2 nodes on the x_2 -axis and \mathcal{O}_6 the orbit with 12 nodes

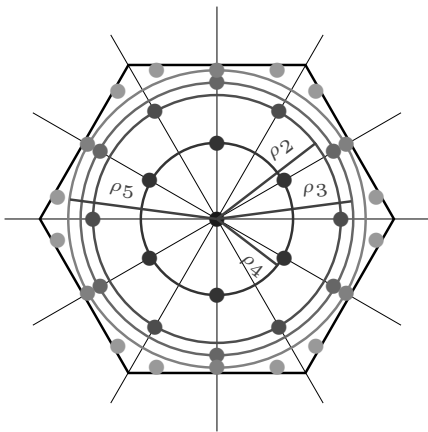

(b) The coordinates of the nodes in \mathcal{O}_2 , \mathcal{O}_3 , \mathcal{O}_4 and \mathcal{O}_5 are determined by the radii ρ_2 , ρ_3 , ρ_4 and ρ_5

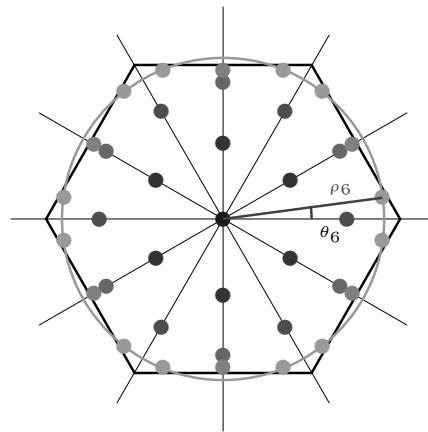

(c) The coordinates of the nodes in \mathcal{O}_6 are determined by the radius ρ_6 and the angle θ_6

Figure 10: Nodes of the cubature in the case (1,1,3,1)

References

- [1] M. Abril Bucero, C. Bajaj, and B. Mourrain. On the construction of general cubature formula by flat extensions. *arXiv:1506.00085v3*, Jun. 2015.
- [2] N. I. Akhiezer. *The classical moment problem and some related questions in analysis*. Translated by N. Kemmer. Hafner Publishing Co., New York, 1965.
- [3] V. Baldoni, N. Berline, J. A. De Loera, M. Köppe, and M. Vergne. How to integrate a polynomial over a simplex. *Math. Comp.*, 80(273):297–325, 2011.
- [4] E. H. Bareiss. Sylvester’s identity and multistep integer-preserving Gaussian elimination. *Math. Comp.*, 22:565–578, 1968.
- [5] E. H. Bareiss. Computational solutions of matrix problems over an integral domain. *J. Inst. Math. Appl.*, 10:68–104, 1972.
- [6] S. Basu, R. Pollack, and M.-F. Roy. *Algorithms in real algebraic geometry*, volume 10 of *Algorithms and Computation in Mathematics*. Springer-Verlag, Berlin, second edition, 2006.
- [7] C. Bayer and J. Teichmann. The proof of Tchakaloff’s theorem. *Proc. Amer. Math. Soc.*, 134(10):3035–3040, 2006.
- [8] M. Ben-Or and P. Tiwari. A deterministic algorithm for sparse multivariate polynomial interpolation. In *Proceedings of the Twentieth Annual ACM Symposium on Theory of Computing*, STOC ’88, pages 301–309. ACM, 1988.
- [9] A. Bernardi, J. Brachat, P. Comon, and B. Mourrain. General tensor decomposition, moment matrices and applications. *J. Symbolic Comput.*, 52:51–71, 2013.
- [10] J. Brachat, P. Comon, B. Mourrain, and E. Tsigaridas. Symmetric tensor decomposition. *Linear Algebra Appl.*, 433(11-12):1851–1872, 2010.
- [11] H.-J. Bungartz and M. Griebel. Sparse grids. *Acta Numer.*, 13:147–269, 2004.
- [12] M. Collowald, A. Cuyt, E. Hubert, W.-S. Lee, and O. Salazar Celis. Numerical reconstruction of convex polytopes from directional moments. *Advances in Computational Mathematics*, pages 1–21, 2015.
- [13] R. Cools. Constructing cubature formulae: the science behind the art. In *Acta numerica, 1997*, volume 6 of *Acta Numer.*, pages 1–54. Cambridge Univ. Press, Cambridge, 1997.
- [14] R. Cools, I. P. Mysovskikh, and H. J. Schmid. Cubature formulae and orthogonal polynomials. *J. Comput. Appl. Math.*, 127(1-2):121–152, 2001. Numerical analysis 2000, Vol. V, Quadrature and orthogonal polynomials.
- [15] R. Cools and P. Rabinowitz. Monomial cubature rules since “Stroud”: a compilation. *J. Comput. Appl. Math.*, 48(3):309–326, 1993.
- [16] R. M. Corless, K. Gatermann, and I. S. Kotsireas. Using symmetries in the eigenvalue method for polynomial systems. *J. Symbolic Comput.*, 44(11):1536–1550, 2009.
- [17] D. A. Cox, J. Little, and D. O’Shea. *Using algebraic geometry*, volume 185 of *Graduate Texts in Mathematics*. Springer, New York, second edition, 2005.

- [18] R. E. Curto and L. A. Fialkow. Solution of the truncated complex moment problem for flat data. *Mem. Amer. Math. Soc.*, 119(568):x+52, 1996.
- [19] R. E. Curto and L. A. Fialkow. The truncated complex K -moment problem. *Trans. Amer. Math. Soc.*, 352(6):2825–2855, 2000.
- [20] C. F. Dunkl and Y. Xu. *Orthogonal polynomials of several variables*, volume 81 of *Encyclopedia of Mathematics and its Applications*. Cambridge University Press, Cambridge, 2001.
- [21] Michael Elad, Peyman Milanfar, and Gene H. Golub. Shape from moments—an estimation theory perspective. *IEEE Trans. Signal Process.*, 52(7):1814–1829, 2004.
- [22] Michael Elad, Peyman Milanfar, and Gene H. Golub. Shape from moments—an estimation theory perspective. *IEEE Trans. Signal Process.*, 52(7):1814–1829, 2004.
- [23] M. Elkadi and B. Mourrain. *Introduction à la résolution des systèmes polynomiaux*, volume 59 of *Mathématiques & Applications (Berlin) [Mathematics & Applications]*. Springer, Berlin, 2007.
- [24] A. Fässler and E. Stiefel. *Group theoretical methods and their applications*. Birkhäuser Boston, Inc., Boston, MA, 1992. Translated from the German by Baoswan Dzung Wong.
- [25] L. Fialkow and S. Petrovic. A moment matrix approach to multivariable cubature. *Integral Equations Operator Theory*, 52(1):85–124, 2005.
- [26] W. Fulton and J. Harris. *Representation theory*, volume 129 of *Graduate Texts in Mathematics*. Springer-Verlag, New York, 1991. A first course, Readings in Mathematics.
- [27] K. Gatermann. The construction of symmetric cubature formulas for the square and the triangle. *Computing*, 40(3):229–240, 1988.
- [28] K. Gatermann. Linear representations of finite groups and the ideal theoretical construction of G -invariant cubature formulas. In *Numerical integration (Bergen, 1991)*, volume 357 of *NATO Adv. Sci. Inst. Ser. C Math. Phys. Sci.*, pages 25–35. Kluwer Acad. Publ., Dordrecht, 1992.
- [29] K. Gatermann and P. A. Parrilo. Symmetry groups, semidefinite programs, and sums of squares. *J. Pure Appl. Algebra*, 192(1-3):95–128, 2004.
- [30] K. O. Geddes, S. R. Czapor, and G. Labahn. *Algorithms for computer algebra*. Kluwer Academic Publishers, Boston, MA, 1992.
- [31] M. Giesbrecht, G. Labahn, and W.-S. Lee. Symbolic-numeric sparse interpolation of multivariate polynomials. *J. Symbolic Comput.*, 44(8):943–959, 2009.
- [32] M. Golubitsky, I. Stewart, and D. G. Schaeffer. *Singularities and groups in bifurcation theory. Vol. II*, volume 69 of *Applied Mathematical Sciences*. Springer-Verlag, New York, 1988.
- [33] N. Gravin, J. Lasserre, D. V. Pasechnik, and S. Robins. The Inverse Moment Problem for Convex Polytopes. *Discrete Comput. Geom.*, 48(3):596–621, 2012.
- [34] R. M. Guralnick. Subgroups inducing the same permutation representation. *J. Algebra*, 81(2):312–319, 1983.

- [35] A. Haegemans. Tables for symmetrical cubature formulas for the two-dimensional hexagon. Technical report, Katholieke Universiteit Leuven, 09 1976.
- [36] A. Haegemans and R. Piessens. Construction of cubature formulas of degree eleven for symmetric planar regions, using orthogonal polynomials. *Numer. Math.*, 25(2):139–148, 1975/76.
- [37] A. Haegemans and R. Piessens. Construction of cubature formulas of degree seven and nine symmetric planar regions, using orthogonal polynomials. *SIAM J. Numer. Anal.*, 14(3):492–508, 1977.
- [38] P. C. Hammer and A. H. Stroud. Numerical evaluation of multiple integrals. II. *Math. Tables Aids Comput.*, 12:272–280, 1958.
- [39] P. Henrici. *Applied and computational complex analysis. Vol. 1.* Wiley Classics Library. John Wiley & Sons, Inc., New York, 1988. Power series—integration—conformal mapping—location of zeros, Reprint of the 1974 original, A Wiley-Interscience Publication.
- [40] D. Henrion, S. Naldi, and M. Safey El Din. Exact algorithms for linear matrix inequalities. [arXiv:1508.03715v1](https://arxiv.org/abs/1508.03715v1), Aug. 2015.
- [41] H. Hong and W. Stocher. Exact division applied to diagonalizing symmetric matrices. Technical report, RISC-Linz, 1994.
- [42] E. Hubert. Convolution surfaces based on polygons for infinite and compact support kernels. *Graphical Models*, 74(1):1–13, 2012.
- [43] E. Hubert and M.-P. Cani. Convolution Surfaces based on Polygonal Curve Skeletons. (An Application of Symbolic Integration to Graphics). *Journal of Symbolic Computation*, 47(6):680–699, 2012.
- [44] T.J.R. Hughes, A. Reali, and G. Sangalli. Efficient quadrature for nurbs-based isogeometric analysis. *Computer Methods in Applied Mechanics and Engineering*, 199(5–8):301 – 313, 2010.
- [45] E. Kaltofen and Y. Lakshman. Improved sparse multivariate polynomial interpolation algorithms. In *Symbolic and algebraic computation (Rome, 1988)*, volume 358 of *Lecture Notes in Comput. Sci.*, pages 467–474. Springer, Berlin, 1989.
- [46] E. Kaltofen and W.-s. Lee. Early termination in sparse interpolation algorithms. *J. Symbolic Comput.*, 36(3-4):365–400, 2003. International Symposium on Symbolic and Algebraic Computation (ISSAC’2002) (Lille).
- [47] S. Kunis, T. Peter, T. Roemer, and U. von der Ohe. A multivariate generalization of prony’s method. [arXiv:1506.00450](https://arxiv.org/abs/1506.00450), Jun. 2015.
- [48] J. B. Lasserre. Global optimization with polynomials and the problem of moments. *SIAM J. Optim.*, 11(3):796–817, 2000/01.
- [49] J. B. Lasserre. *Moments, positive polynomials and their applications*, volume 1 of *Imperial College Press Optimization Series*. Imperial College Press, London, 2010.
- [50] J. B. Lasserre. The existence of Gaussian cubature formulas. *J. Approx. Theory*, 164(5):572–585, 2012.

- [51] J. B. Lasserre, M. Laurent, B. Mourrain, P. Rostalski, and P. Trébuchet. Moment matrices, border bases and real radical computation. *J. Symbolic Comput.*, 51:63–85, 2013.
- [52] J. B. Lasserre, M. Laurent, and P. Rostalski. Semidefinite characterization and computation of zero-dimensional real radical ideals. *Found. Comput. Math.*, 8(5):607–647, 2008.
- [53] J. B. Lasserre, M. Laurent, and P. Rostalski. A unified approach to computing real and complex zeros of zero-dimensional ideals. In *Emerging applications of algebraic geometry*, volume 149 of *IMA Vol. Math. Appl.*, pages 125–155. Springer, New York, 2009.
- [54] M. Laurent. Revisiting two theorems of Curto and Fialkow on moment matrices. *Proc. Amer. Math. Soc.*, 133(10):2965–2976, 2005.
- [55] M. Laurent. Sums of squares, moment matrices and optimization over polynomials. In *Emerging applications of algebraic geometry*, volume 149 of *IMA Vol. Math. Appl.*, pages 157–270. Springer, New York, 2009.
- [56] M. Laurent and B. Mourrain. A generalized flat extension theorem for moment matrices. *Arch. Math. (Basel)*, 93(1):87–98, 2009.
- [57] O. P. Le Maître and O. M. Knio. *Spectral methods for uncertainty quantification*. Scientific Computation. Springer, New York, 2010. With applications to computational fluid dynamics.
- [58] H. Li, J. Sun, and Y. Xu. Discrete Fourier analysis, cubature, and interpolation on a hexagon and a triangle. *SIAM J. Numer. Anal.*, 46(4):1653–1681, 2008.
- [59] A. Mantzaflaris, B. Juettler, B. Khoromskij, and U. Langer. Matrix generation in isogeometric analysis by low rank tensor approximation. (To appear), 2015.
- [60] A. Mazzia, M. Ferronato, G. Pini, and G. Gambolati. A comparison of numerical integration rules for the meshless local Petrov-Galerkin method. *Numer. Algorithms*, 45(1-4):61–74, 2007.
- [61] A. Mazzia and G. Pini. Product Gauss quadrature rules vs. cubature rules in the meshless local Petrov-Galerkin method. *J. Complexity*, 26(1):82–101, 2010.
- [62] P. Milanfar, G. Verghese, C. Karl, and A. Willsky. Reconstructing polygons from moments with connections to array processing. *IEEE Transactions on Signal Processing*, 43:432–443, 1995.
- [63] H. M. Möller. An inverse problem for cubature formulae. *Vychislitelnye Tekhnologii (Computational Technologies)*, 9:13–20, 2004.
- [64] B. Mourrain and V. Y. Pan. Multivariate polynomials, duality, and structured matrices. *J. Complexity*, 16(1):110–180, 2000. Real computation and complexity (Schloss Dagstuhl, 1998).
- [65] D. Potts and M. Tasche. Parameter estimation for exponential sums by approximate prony method. *Signal Processing*, 90(5):1631–1642, 2010.
- [66] D. Potts and M. Tasche. Parameter estimation for multivariate exponential sums. *Electron. Trans. Numer. Anal.*, 40:204–224, 2013.

- [67] M. Putinar. A note on Tchakaloff’s theorem. *Proc. Amer. Math. Soc.*, 125(8):2409–2414, 1997.
- [68] M. Putinar. A dilation theory approach to cubature formulas. II. *Math. Nachr.*, 211:159–175, 2000.
- [69] P. Rabinowitz and N. Richter. Perfectly symmetric two-dimensional integration formulas with minimal numbers of points. *Math. Comp.*, 23:765–779, 1969.
- [70] J. Radon. Zur mechanischen Kubatur. *Monatsh. Math.*, 52:286–300, 1948.
- [71] C. (Baron de Prony) Riche. Essai expérimental et analytique sur les lois de la dilatabilité des fluides élastique et sur celles de la force expansive de la vapeur de l’eau et de la vapeur de l’alkool, à différentes températures. *J. de l’École Polytechnique*, 1:24–76, 1795.
- [72] C. Riener, T. Theobald, L. J. Andrén, and Jean B. Lasserre. Exploiting symmetries in SDP-relaxations for polynomial optimization. *Math. Oper. Res.*, 38(1):122–141, 2013.
- [73] F. Rouillier. Formules de Bareiss et réduction de formes quadratiques. *C. R. Acad. Sci. Paris Sér. I Math.*, 320(10):1273–1277, 1995.
- [74] H. J. Schmid and Y. Xu. On bivariate Gaussian cubature formulae. *Proc. Amer. Math. Soc.*, 122(3):833–841, 1994.
- [75] J.-P. Serre. *Linear representations of finite groups*. Springer-Verlag, New York-Heidelberg, 1977. Translated from the second French edition by Leonard L. Scott, Graduate Texts in Mathematics, Vol. 42.
- [76] S. Sheynin and A. Tuzikov. Explicit formulae for polyhedra moments. *Pattern Recogn. Lett.*, 22:1103–1109, 2001.
- [77] J. Stoer and R. Bulirsch. *Introduction to numerical analysis*, volume 12 of *Texts in Applied Mathematics*. Springer-Verlag, New York, third edition, 2002. Translated from the German by R. Bartels, W. Gautschi and C. Witzgall.
- [78] A. H. Stroud. *Approximate calculation of multiple integrals*. Prentice-Hall, Inc., Englewood Cliffs, N.J., 1971. Prentice-Hall Series in Automatic Computation.
- [79] B. Sturmfels. *Algorithms in invariant theory*. Texts and Monographs in Symbolic Computation. Springer-Verlag, Vienna, 1993.
- [80] M. Sylvester. Sur une extension du théorème de Clebsch relatif aux courbes du quatrième degré. *Comptes rendus hebdomadaires des séances de l’Académie des sciences*, 102, 1886.
- [81] P. Verlinden and R. Cools. On cubature formulae of degree $4k + 1$ attaining Möller’s lower bound for integrals with circular symmetry. *Numer. Math.*, 61(3):395–407, 1992.
- [82] C. Zanni, A. Bernhardt, M. Quiblier, and M.-P. Cani. SCALE-invariant Integral Surfaces. *Computer Graphics Forum*, 32(8):219–232, December 2013.
- [83] C. Zanni, E. Hubert, and M.-P. Cani. Warp-based helical implicit primitives. *Computers & Graphics*, 35(3):517 – 523, 2011.
- [84] F. Zhang. *Matrix theory*. Universitext. Springer, New York, second edition, 2011. Basic results and techniques.