



HAL
open science

60/102 Null Boundary Cellular Automata based expander graphs

Sung-Jin Cho, Un-Sook Choi, Han-Doo Kim, Yoon-Hee Hwang, Jin-Gyoung
Kim

► **To cite this version:**

Sung-Jin Cho, Un-Sook Choi, Han-Doo Kim, Yoon-Hee Hwang, Jin-Gyoung Kim. 60/102 Null Boundary Cellular Automata based expander graphs. Automata 2010 - 16th Intl. Workshop on CA and DCS, 2010, Nancy, France. pp.19-28, 10.46298/dmtcs.2760 . hal-01185496

HAL Id: hal-01185496

<https://inria.hal.science/hal-01185496>

Submitted on 20 Aug 2015

HAL is a multi-disciplinary open access archive for the deposit and dissemination of scientific research documents, whether they are published or not. The documents may come from teaching and research institutions in France or abroad, or from public or private research centers.

L'archive ouverte pluridisciplinaire **HAL**, est destinée au dépôt et à la diffusion de documents scientifiques de niveau recherche, publiés ou non, émanant des établissements d'enseignement et de recherche français ou étrangers, des laboratoires publics ou privés.

60/102 Null Boundary Cellular Automata based expander graphs

Sung-Jin Cho^{1†}Un-Sook Choi²Han-Doo Kim³Yoon-Hee Hwang¹Jin-Gyoung Kim¹¹*Department of Applied Mathematics, Pukyong National University, Busan 608-737, Korea*²*Department of Media Engineering, Tongmyong University, Busan 626-847, Korea*³*School of Computer Aided Science, Institute of Basic Science, Inje University, KimHae 621-749, Korea*

Expander graphs are useful in the design and analysis of communication networks. Mukhopadhyay et al. introduced a method to generate a family of expander graphs based on nongroup two predecessor single attractor Cellular Automata(CA). In this paper we propose a method to generate a family of expander graphs based on 60/102 Null Boundary CA(NBCA) which is a group CA. The spectral gap generated by our method is maximal. Moreover, the spectral gap is larger than that of Mukhopadhyay et al.

Keywords: Expander graphs, 60/102 NBCA, Spectral gaps, Bipartite graphs, Eigenvalue.

1 Introduction

Expander graphs were first defined by Bassalygo and Pinsker and their existence first proved by Pinsker in the early 1970s [10]. Also expander graphs have utility in computational settings such as in the theory of error correcting codes and the theory of pseudorandomness as well as a tool for proving results in number theory and computational complexity [6, 8, 11]. Expander graphs are useful in the design and analysis of communication networks. Mukhopadhyay et al. introduced a method to generate a family of expander graphs based on nongroup two predecessor single attractor Cellular Automata(CA). In this paper we propose a method to generate a family of expander graphs based on 60/102 Null Boundary CA(NBCA) which is a group CA. The merit of our method is that it use regular, modular and cascable structure of 60/102 NBCA [1, 3, 4] to generate regular graphs of good expansion property with less storage. The spectral gap generated by our method is maximal. Moreover, the spectral gap is larger than that of Mukhopadhyay et al. [9].

2 Preliminaries

CA consist of a number of interconnected cells arranged spatially in a regular manner, where the state transition of each cell depends on the states of its neighbors. The CA structure investigated by Wolfram

[†]This work was supported by the Pukyong University Research Fund in 2009(PK-2009-26).

[12] can be viewed as a discrete lattice of sites (cells), where each cell can assume the value either 0 or 1. The next-state of a cell is assumed to depend on itself and on its two neighbors (3-neighborhood dependency). If the next-state function of a cell is expressed in the form of a truth table, then the decimal equivalent of the output is conventionally called the rule number for the cell.

Neighborhood state	111	110	101	100	011	010	001	000	
Next state	0	0	1	1	1	1	0	0	rule 60
Next state	0	1	1	0	0	1	1	0	rule 102

The top row gives all eight possible states of the three neighboring cells (the left neighbor of the i th cell, the i th cell itself, and its right neighbor) at the time of instant t . The second and third rows give the corresponding states of the i th cell at the time of instant $t + 1$ for two illustrative CA rules.

Informally, expander graph is a graph $G = (V, E)$ in which every subset S of vertices *expands* quickly, in the sense that it is connected to many vertices in the set \bar{S} of complementary vertices.

Definition 2.1 ([8]). Suppose $G = (V, E)$ has n vertices. For a subset S of V define the *edge boundary* of S , ∂S , to be the set of edges connecting S to its complement \bar{S} . That is, ∂S consists of all those edges (v, w) such that $v \in S$ and $w \notin S$. The *expansion parameter* for G is defined by

$$h(G) \equiv \min_{S: |S| \leq n/2} \frac{|\partial S|}{|S|}$$

where $|X|$ denotes the size of a set X .

Example 2.2. Suppose G is the complete graph with n vertices, i.e., the graph in which every vertex is connected to every other vertex. Then for any vertex in S , each vertex in \bar{S} is connected to all the vertices in \bar{S} , and thus $|\partial S| = |S| \times |\bar{S}| = |S|(n - |S|)$. It follows that the expansion parameter for G is given by

$$h(G) \equiv \min_{S: |S| \leq n/2} (n - |S|) = \lceil \frac{n}{2} \rceil$$

It is a marvellous fact that properties of the *eigenvalue spectrum* of the adjacency matrix $A(G)$ can be used to understand properties of the graph G . This occurs so frequently that we refer to the spectrum of $A(G)$ as *the spectrum of the graph G* . It is useful because the eigenvalue spectrum can be computed quickly, and certain properties, such as the largest and smallest eigenvalue, the determinant and trace, can be computed extremely quickly [8].

Let $G = (V, E)$ be an undirected graph and $A(G)$ be the adjacency matrix of the graph G . And let $\lambda_i(A(G))$ ($1 \leq i \leq n$) be eigenvalues of $A(G)$. Then $A(G)$ is a real symmetric matrix and thus diagonalized. Without loss of generality we can assume that $\lambda_1(A(G)) \geq \lambda_2(A(G)) \geq \dots \geq \lambda_n(A(G))$.

Lemma 2.3. [1] Let \mathbb{C} be a CA where state transition matrix T and \mathbb{C}' be the complemented CA derived from \mathbb{C} where state transition operator \bar{T} . And let \bar{T}^p denote p times application of the complemented CA operator \bar{T} . Then

$$\bar{T}^p f(x) = [I \oplus T \oplus T^2 \oplus \dots \oplus T^{p-1}] F(x) \oplus T^p f(x)$$

4 60/102 NBCA based expander graphs

In this section we show a construction of a family of random d -regular graphs using 60/102 NBCA. Let \mathbb{C} be the n -cell 60/102 NBCA whose state transition matrix T is as the following:

$$T = \begin{pmatrix} 1 & 0 & 0 & 0 & \cdots & 0 & 0 & 0 & 0 \\ 0 & 1 & 1 & 0 & \cdots & 0 & 0 & 0 & 0 \\ 0 & 0 & 1 & 1 & \cdots & 0 & 0 & 0 & 0 \\ \vdots & \vdots & \vdots & \vdots & \ddots & \vdots & \vdots & \vdots & \vdots \\ 0 & 0 & 0 & 0 & \cdots & 1 & 1 & 0 & 0 \\ 0 & 0 & 0 & 0 & \cdots & 0 & 1 & 1 & 0 \\ 0 & 0 & 0 & 0 & \cdots & 0 & 0 & 1 & 1 \end{pmatrix}$$

Hereafter we write T by $T = \langle 60, 102, 102, \dots, 102 \rangle$.

Clearly the characteristic (resp. minimal) polynomial $c(x)$ (resp. $m(x)$) of T is $c(x) = (x+1)^n$ (resp. $m(x) = (x+1)^{n-1}$). Since $m(x) = (x+1)^{n-1}$, we can obtain the following result. The proof of Theorem 4.1 is very similar to the proof of Theorem 3.4 in [3].

Theorem 4.1. *Let \mathbb{C} be the n -cell 60/102 NBCA with state transition matrix $T = \langle 60, 102, 102, \dots, 102 \rangle$. Let \mathbb{C}' be the complemented CA derived from \mathbb{C} with complement vector $(a_1, \dots, a_{n-1}, 1)^t$ ($a_i \in \{0, 1\}, i = 1, 2, \dots, n-1$ where \mathbf{x}^t is the transpose of the given vector \mathbf{x}) and state transition operator \bar{T} . If $\text{ord}(T) = 2^a$, then the following hold:*

(a) *all the lengths of cycles in \mathbb{C}' are the same.*

(b) $\text{ord}(\bar{T}) = \begin{cases} 2^a, & \text{if } 2^{a-1} < n-1 < 2^a, \\ 2^{a+1}, & \text{if } n-1 = 2^{a+1}. \end{cases}$

Remark A. *By Theorem 4.1, the state transition diagram of \mathbb{C}' does not have any attractor.*

Example 4.2. Let \mathbb{C} be the 4-cell 60/102 NBCA whose state transition matrix is $T = \langle 60, 102, 102, 102 \rangle$. Then the structure and the state transition diagram of \mathbb{C} are as in Figs. 1(a) and 1(b).

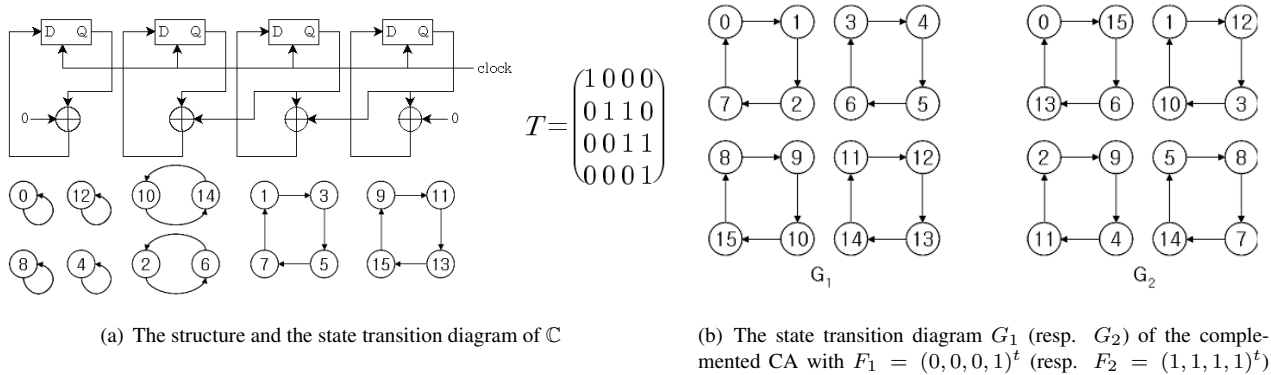

Fig. 1:

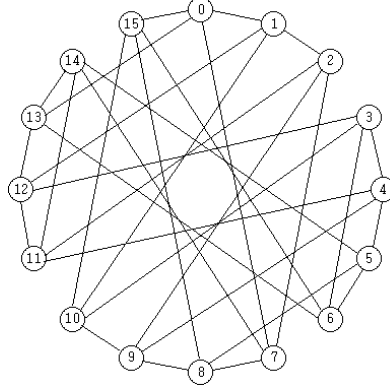

Fig. 2: The graph G

Let $F_1 = (0, 0, 0, 1)^t$. Then by Lemma 2.3 $\bar{T}0 = 1, \bar{T}1 = 2, \bar{T}2 = 7, \bar{T}3 = 4, \bar{T}4 = 5, \dots, \bar{T}14 = 11$ and $\bar{T}15 = 8$. Thus we obtain the state transition diagram G_1 of the state transition operator \bar{T} of the complemented CA \mathbb{C}'_1 with complement vector $F_1 = (0, 0, 0, 1)^t$ of \mathbb{C} . Also we see that $ord(\bar{T}) = ord(T) = 4$ and all lengths of cycles in \mathbb{C} are all the same by Theorem 4.1.

Fig. 1(b) shows the state transition diagram G_1 and G_2 of the complemented CA with $F_1 = (0, 0, 0, 1)^t$ and $F_2 = (1, 1, 1, 1)^t$ respectively whose two adjacency 8×8 matrices $A(G_1)$ and $A(G_2)$ respectively using Example 4.2 are as the following.

$$A(G_1) = \begin{pmatrix} 0 & 1 & 0 & 0 & 0 & 0 & 0 & 1 & 0 & 0 & 0 & 0 & 0 & 0 & 0 & 0 \\ 1 & 0 & 1 & 0 & 0 & 0 & 0 & 0 & 0 & 0 & 0 & 0 & 0 & 0 & 0 & 0 \\ 0 & 1 & 0 & 1 & 0 & 0 & 0 & 0 & 0 & 0 & 0 & 0 & 0 & 0 & 0 & 0 \\ 1 & 0 & 1 & 0 & 0 & 0 & 0 & 0 & 0 & 0 & 0 & 0 & 0 & 0 & 0 & 0 \\ 0 & 0 & 0 & 0 & 0 & 1 & 0 & 1 & 0 & 0 & 0 & 0 & 0 & 0 & 0 & 0 \\ 0 & 0 & 0 & 0 & 1 & 0 & 1 & 0 & 0 & 0 & 0 & 0 & 0 & 0 & 0 & 0 \\ 0 & 0 & 0 & 0 & 1 & 0 & 1 & 0 & 0 & 0 & 0 & 0 & 0 & 0 & 0 & 0 \\ 0 & 0 & 0 & 0 & 1 & 0 & 1 & 0 & 0 & 0 & 0 & 0 & 0 & 0 & 0 & 0 \\ 0 & 0 & 0 & 0 & 1 & 0 & 1 & 0 & 0 & 0 & 0 & 0 & 0 & 0 & 0 & 0 \\ 0 & 0 & 0 & 0 & 1 & 0 & 1 & 0 & 0 & 0 & 0 & 0 & 0 & 0 & 0 & 0 \\ 0 & 0 & 0 & 0 & 1 & 0 & 1 & 0 & 0 & 0 & 0 & 0 & 0 & 0 & 0 & 0 \\ 0 & 0 & 0 & 0 & 0 & 0 & 0 & 0 & 1 & 0 & 0 & 0 & 0 & 0 & 0 & 1 \\ 0 & 0 & 0 & 0 & 0 & 0 & 0 & 0 & 1 & 0 & 1 & 0 & 0 & 0 & 0 & 0 \\ 0 & 0 & 0 & 0 & 0 & 0 & 0 & 0 & 1 & 0 & 1 & 0 & 0 & 0 & 0 & 0 \\ 0 & 0 & 0 & 0 & 0 & 0 & 0 & 0 & 0 & 0 & 0 & 1 & 0 & 1 & 0 & 0 \\ 0 & 0 & 0 & 0 & 0 & 0 & 0 & 0 & 0 & 0 & 0 & 1 & 0 & 1 & 0 & 0 \\ 0 & 0 & 0 & 0 & 0 & 0 & 0 & 0 & 0 & 0 & 0 & 1 & 0 & 1 & 0 & 0 \\ 0 & 0 & 0 & 0 & 0 & 0 & 0 & 0 & 0 & 0 & 0 & 1 & 0 & 1 & 0 & 0 \\ 0 & 0 & 0 & 0 & 0 & 0 & 0 & 0 & 0 & 0 & 0 & 1 & 0 & 1 & 0 & 0 \\ 0 & 0 & 0 & 0 & 0 & 0 & 0 & 0 & 0 & 0 & 0 & 1 & 0 & 1 & 0 & 0 \end{pmatrix} \quad A(G_2) = \begin{pmatrix} 0 & 0 & 0 & 0 & 0 & 0 & 0 & 0 & 0 & 0 & 0 & 0 & 0 & 0 & 1 & 0 & 1 \\ 0 & 0 & 0 & 0 & 0 & 0 & 0 & 0 & 0 & 0 & 0 & 1 & 0 & 1 & 0 & 0 & 0 \\ 0 & 0 & 0 & 0 & 0 & 0 & 0 & 0 & 0 & 0 & 0 & 1 & 0 & 1 & 0 & 0 & 0 \\ 0 & 0 & 0 & 0 & 0 & 0 & 0 & 0 & 0 & 0 & 0 & 1 & 0 & 1 & 0 & 0 & 0 \\ 0 & 0 & 0 & 0 & 0 & 0 & 0 & 0 & 0 & 0 & 0 & 1 & 0 & 1 & 0 & 0 & 0 \\ 0 & 0 & 0 & 0 & 0 & 0 & 0 & 0 & 0 & 0 & 0 & 1 & 0 & 1 & 0 & 0 & 0 \\ 0 & 0 & 0 & 0 & 0 & 0 & 0 & 0 & 0 & 0 & 0 & 1 & 0 & 1 & 0 & 0 & 0 \\ 0 & 0 & 0 & 0 & 0 & 0 & 0 & 0 & 0 & 0 & 0 & 1 & 0 & 1 & 0 & 0 & 0 \\ 0 & 0 & 0 & 0 & 0 & 0 & 0 & 0 & 0 & 0 & 0 & 1 & 0 & 1 & 0 & 0 & 0 \\ 0 & 0 & 0 & 0 & 0 & 0 & 0 & 0 & 0 & 0 & 0 & 1 & 0 & 1 & 0 & 0 & 0 \\ 0 & 0 & 0 & 0 & 0 & 0 & 0 & 0 & 0 & 0 & 0 & 1 & 0 & 1 & 0 & 0 & 0 \\ 0 & 0 & 0 & 0 & 0 & 0 & 0 & 0 & 0 & 0 & 0 & 1 & 0 & 1 & 0 & 0 & 0 \\ 0 & 0 & 0 & 0 & 0 & 0 & 0 & 0 & 0 & 0 & 0 & 1 & 0 & 1 & 0 & 0 & 0 \\ 0 & 0 & 0 & 0 & 0 & 0 & 0 & 0 & 0 & 0 & 0 & 1 & 0 & 1 & 0 & 0 & 0 \\ 0 & 0 & 0 & 0 & 0 & 0 & 0 & 0 & 0 & 0 & 0 & 1 & 0 & 1 & 0 & 0 & 0 \\ 0 & 0 & 0 & 0 & 0 & 0 & 0 & 0 & 0 & 0 & 0 & 1 & 0 & 1 & 0 & 0 & 0 \\ 0 & 0 & 0 & 0 & 0 & 0 & 0 & 0 & 0 & 0 & 0 & 1 & 0 & 1 & 0 & 0 & 0 \end{pmatrix}$$

Let G be the graph obtained by the union of the graphs G_1 and G_2 . Then $A(G)$ is as the following:

$$A(G) = \begin{pmatrix} 0 & 1 & 0 & 0 & 0 & 0 & 0 & 1 & 0 & 0 & 0 & 0 & 0 & 1 & 0 & 1 \\ 1 & 0 & 1 & 0 & 0 & 0 & 0 & 0 & 0 & 0 & 1 & 0 & 1 & 0 & 0 & 0 \\ 0 & 1 & 0 & 0 & 0 & 0 & 0 & 1 & 0 & 1 & 0 & 1 & 0 & 0 & 0 & 0 \\ 0 & 0 & 0 & 0 & 1 & 0 & 1 & 0 & 0 & 0 & 0 & 1 & 0 & 1 & 0 & 0 \\ 0 & 0 & 0 & 1 & 0 & 1 & 0 & 0 & 0 & 0 & 1 & 0 & 1 & 0 & 0 & 0 \\ 0 & 0 & 0 & 0 & 1 & 0 & 1 & 0 & 1 & 0 & 0 & 0 & 0 & 0 & 1 & 0 \\ 0 & 0 & 0 & 1 & 0 & 1 & 0 & 0 & 0 & 0 & 0 & 0 & 0 & 1 & 0 & 1 \\ 1 & 0 & 1 & 0 & 0 & 0 & 0 & 0 & 1 & 0 & 0 & 0 & 0 & 0 & 1 & 0 \\ 0 & 0 & 0 & 0 & 0 & 1 & 0 & 1 & 0 & 1 & 0 & 0 & 0 & 0 & 0 & 1 \\ 0 & 0 & 1 & 0 & 1 & 0 & 0 & 0 & 0 & 1 & 0 & 0 & 0 & 0 & 0 & 0 \\ 0 & 1 & 0 & 1 & 0 & 0 & 0 & 0 & 0 & 1 & 0 & 0 & 0 & 0 & 0 & 1 \\ 0 & 0 & 1 & 0 & 1 & 0 & 0 & 0 & 0 & 0 & 0 & 0 & 1 & 0 & 1 & 0 \\ 0 & 1 & 0 & 1 & 0 & 0 & 0 & 0 & 0 & 0 & 0 & 1 & 0 & 1 & 0 & 0 \\ 1 & 0 & 0 & 0 & 0 & 0 & 1 & 0 & 0 & 0 & 0 & 0 & 1 & 0 & 1 & 0 \\ 0 & 0 & 0 & 0 & 0 & 1 & 0 & 1 & 0 & 0 & 0 & 0 & 1 & 0 & 1 & 0 \\ 1 & 0 & 0 & 0 & 0 & 0 & 1 & 0 & 1 & 0 & 0 & 0 & 0 & 1 & 0 & 1 & 0 \end{pmatrix}$$

The characteristic polynomial of $A(G)$ is $x^6(x - 4)(x + 4)(x - 2)^4(x + 2)^4$. Hence the eigenvalues of

$A(G)$ are $\lambda_1 = 4, \lambda_2 = \dots = \lambda_5 = 2, \lambda_6 = \dots = \lambda_{11} = 0, \lambda_{12} = \dots = \lambda_{15} = -2, \lambda_{16} = -4$. Therefore by Theorem 3.2 and Theorem 3.3 G is connected and bipartite. Fig. 2 shows the graph G with the adjacency matrix $A(G)$.

Theorem 4.3. *Let \mathbb{C} be the 60/102 NBCA whose state transition matrix is T . Let \mathbb{C}'_1 (resp. \mathbb{C}'_2) be the complemented CA derived from \mathbb{C} with the complement vector $F_1 = (0, *, \dots, *, 1)^t$ (resp. $F_2 = (1, *, \dots, *, 1)^t$). Also let $\overline{T}_1 X = TX \oplus F_1$ and $\overline{T}_2 X = TX \oplus F_2$. Let G_1 (resp. G_2) be the graph obtained from \mathbb{C}'_1 (resp. \mathbb{C}'_2). And let G be the union of two graphs G_1 and G_2 whose adjacency matrix is $A(G_1)$ and $A(G_2)$ respectively. Then G is a bipartite 4-regular graph.*

Table 1 shows the eigenvalue spectrum of $A(G)$ which is the union of G_1 and G_2 . In Table 1 let $F_1 = (0, 1, 1, 1)^t$ and $F_2 = (1, 1, 0, 1)^t$. Then the eigenvalue spectrum of $A(G)$ is $\lambda_1 = 4, \lambda_2 = \dots = \lambda_5 = 2, \lambda_6 = \dots = \lambda_{11} = 0, \lambda_{12} = \dots = \lambda_{15} = -2, \lambda_{16} = -4$. Therefore in this case the graph G is a bipartite 4-regular graph.

Table 2 shows the result of an experimentation performed with the 60/102 NBCA based regular graph. It measures the value of the two largest eigenvalues for random 60/102 NBCA based graphs for degree 4, 8, 12 and 16. Our results show that the spectral gap and hence the expansion increases proportionately with the number of union operations (t). Table 3 shows that the spectral gap by the our method is larger than the spectral gap by Mukhopadhyay's method [9].

Theorem 4.4. *Let \mathbb{C} be the n -cell 60/102 NBCA. Also let $\mathbf{x} = (x_1, x_2, \dots, x_n)^t$ be a state of the state transition diagram of the state transition matrix T of \mathbb{C} . Then the immediate predecessor $\mathbf{y} = (y_1, y_2, \dots, y_n)^t$ of \mathbf{x} satisfies the following:*

$$y_1 = x_1, y_n = x_n, y_k = x_k \oplus y_{k+1} \quad (k = 2, \dots, n-1)$$

Remark B. *It is easy to see that the inverse matrix T^{-1} of T is of the following form.*

$$T^{-1} = \begin{pmatrix} 1 & 0 & 0 & \dots & 0 & 0 & 0 \\ 0 & 1 & 1 & \dots & 1 & 1 & 1 \\ 0 & 0 & 1 & \dots & 1 & 1 & 1 \\ \vdots & \vdots & \vdots & \ddots & \vdots & \vdots & \vdots \\ 0 & 0 & 0 & \dots & 1 & 1 & 1 \\ 0 & 0 & 0 & \dots & 0 & 1 & 1 \\ 0 & 0 & 0 & \dots & 0 & 0 & 1 \end{pmatrix}$$

So the required time to get the immediate predecessors is $O(n)$. For the given n -cell 60/102 NBCA, the construction of d -regular graphs which have the maximum spectral gaps depend on the relationship between F_1 and F_2 . For example, in Table 1 let $F_1 = (0, 0, 0, 1)^t$ and $F_2 = (1, 1, 1, 1)^t$. Then the spectral gap is 2 which is the maximum value in the 4-regular graph.

Now let

$$F_{11} = \{(0, a_2, a_3, \dots, a_{n-2}, 0, 1) | a_i \in \{0, 1\}, i = 2, \dots, n-2\}$$

$$F_{12} = \{(0, a_2, a_3, \dots, a_{n-2}, 1, 1) | a_i \in \{0, 1\}, i = 2, \dots, n-2\}$$

$$F_{21} = \{(1, a_2, a_3, \dots, a_{n-2}, 1, 1) | a_i \in \{0, 1\}, i = 2, \dots, n-2\}$$

$$F_{22} = \{(1, a_2, a_3, \dots, a_{n-2}, 0, 1) | a_i \in \{0, 1\}, i = 2, \dots, n-2\}$$

and let $U = (F_{11} \times F_{21}) \cup (F_{12} \times F_{22})$.

Tab. 1: The eigenvalue spectrum of $A(G)$. The eight vectors on the first row(resp. column) are the complement vectors F_1 (resp. F_2)

	0000	0010	0100	0110	0001	0011	0101	0111
1000	-4(2)	-4(1)	-4(2)	-4(1)				
1100	0(10)	-2(4)	0(10)	-2(4)	-4(1)	-4(1)	-4(1)	-4(1)
	4(4)	0(4)	4(4)	0(4)	-2.8284(2)	-2.8284(2)	-2.8284(2)	-2.8284(2)
		2(4)		2(4)	-2(2)	-2(2)	-2(2)	-2(2)
		4(3)		4(3)	0(6)	0(6)	0(6)	0(6)
1010	-4(1)	-4(2)	-4(1)	-4(2)	2(2)	2(2)	2(2)	2(2)
1110	-2(4)	0(10)	-2(4)	0(10)	2.8284(2)	2.8284(2)	2.8284(2)	2.8284(2)
	0(4)	4(4)	0(4)	4(4)	4(1)	4(1)	4(1)	4(1)
	2(4)		2(4)					
	4(3)		4(3)					
1001					-4(2)	-4(1)	-4(2)	-4(1)
1101					0(12)	-2(4)	0(12)	-2(4)
	-2.8284(2)	-2.8284(2)	-2.8284(2)	-2.8284(2)	4(2)	0(6)	4(2)	0(6)
	-2(2)	-2(2)	-2(2)	-2(2)		2(4)		2(4)
	0(6)	0(6)	0(6)	0(6)		4(1)		4(1)
1011	2(2)	2(2)	2(2)	2(2)	-4(1)	-4(2)	-4(1)	-4(2)
1111	2.8284(2)	2.8284(2)	2.8284(2)	2.8284(2)	-2(4)	0(12)	-2(4)	0(12)
	4(2)	4(2)	4(2)	4(2)	0(6)	4(2)	0(6)	4(2)
					2(4)		2(4)	
					4(1)		4(1)	

Tab. 2: Spectrum of the 4-cell 60/102 NBCA based regular graph

No. of Union (t)	Complement vector	Degree	First Eigenvalue	Second Eigenvalue	Spectral Gap (g)	g/t
1	1,15	4	4	2	2	2
3	1,3,9,15	8	8	4	4	1.33
5	1,3,5,9,11,15	12	12	2	10	2
7	1,3,5,7,9,11,13,15	16	16	0	16	2.2857

Tab. 3: Comparison of Mukhopadhyay’s spectral gaps with our spectral gaps

No. of Union (t)	g/t(Mukhopadhyay’s method)	g/t(Our method)
1	0.76	2
3	1.03	1.33
5	1.14	2
7	1.54	2.2857

Choose the complement vectors F_1, F_2 such that $(F_1, F_2) \in U$. Let G_1 (resp. G_2) be the graph with F_1 (resp. F_2). Then we can construct an expander graph where spectral gap is maximal.

The following algorithm shows computing the four neighbors of a vertex in G which is the union of G_1 and G_2 .

Algorithm (Computing neighbors of a vertex in G).

Input: Complement vectors $(F_1, F_2) \in K$ and a state $\mathbf{x} \in G$.

Output: The four neighbors (S_1, S_2, P_1, P_2) of \mathbf{x} .

Step 1: Find the next state S_1 (resp. S_2) of \mathbf{x} using the operator \bar{T}_1 (resp. \bar{T}_2).

$$S_1 = \bar{T}_1 \mathbf{x} = T\mathbf{x} \oplus F_1$$

$$S_2 = \bar{T}_2 \mathbf{x} = T\mathbf{x} \oplus F_2$$

/ Find the immediate predecessor P_1 (resp. P_2) by using Theorem 4.4 in Step 2 and Step 3 */*

Step 2: Compute $W := \mathbf{x} \oplus F_1$ and $V := \mathbf{x} \oplus F_2$.

Step 3: For $W = (w_1, w_2, \dots, w_n)$, $V = (v_1, v_2, \dots, v_n)$ and $k = 2, \dots, n-1$ find $P_1 := (p_{11}, p_{12}, \dots, p_{1n})$ and $P_2 := (p_{21}, p_{22}, \dots, p_{2n})$

$$p_{11} = w_1, \quad p_{1n} = w_n, \quad p_{1k} = w_k \oplus p_{1k+1}$$

$$p_{21} = v_1, \quad p_{2n} = v_n, \quad p_{2k} = v_k \oplus p_{2k+1}$$

In general the description of an expander d -regular graph grows exponentially with the number of vertices as the increase of the size of 60/102 NBCA. However as we require to store only two complement vectors F_1 and F_2 , this problem is solved by the above algorithm.

5 Conclusion

In this paper, we proposed a method to generate expander graphs with good expansion properties based on group 60/102 NBCA. The expansion properties by our method is better than the expansion properties proposed by Mukhopadhyay et al.

References

- [1] P. Pal Chaudhuri, D. Roy Chowdhury, S. Nandi, and S. Chattopadhyay. Additive cellular automata theory and its application i, ieee computer society press, california. *IEEE Computer Society Press, California*, 2000.
- [2] J. Cheeger. A lower bound for the smallest eigenvalue of the laplacian. in problems in analysis(papers dedicated to solomon bochner, 1969, 195-199). *Princeton Univ. Press*, 1970.
- [3] S.J. Cho, U.S. Choi, H.D. Kim, and Y.H. Hwang. Analysis of complemented ca derived from linear hybrid group ca, computers and mathematics with applications. *Computers and Mathematics with Applications*, 53:54–63, 2007.
- [4] S.J. Cho, U.S. Choi, H.D. Kim, Y.H. Hwang, J.G. Kim, and S.H. Heo. New synthesis of one-dimensional 90/150 linear hybrid group cellular automata. *IEEE Transactions on Computer-Aided Design of Integrated Circuits and Systems*, 26:1720–1724, 2007.
- [5] W. Diffie and M. Hellman. New direction in cryptography. *IEEE Transaction on Information Theory*, pages 644–654, 1976.
- [6] D.Peleg and E.Upfal. Constructing disjoint paths on expander graphs. *Combinatorica*, pages 289–313, 1989.
- [7] O. Goldreich. Candidate one-way functions based on expander graphs. *Cryptology ePrint Archive, Report 2000/063*, pages 1–9, 2000.
- [8] S. Hoory, N. Lindal, and A. Wigderson. Expander graphs and their applications. *Bull. AMS*, 2006.
- [9] D. Mukhopadhyay and D.R. Chowdhury. Generation of expander graphs using cellular automata and its applications to cryptography. *LNCS*, 4173:636–645, 2006.
- [10] M.S. Pinsky. On the complexity of a concentrator. In *7th International Teletraffic Conference*, pages 1–4, 1973.
- [11] M. Sipser and D. Spielman. Expander codes. *IEEE Transactions on Information Theory*, 42:1710–1722, 1996.
- [12] S. Wolfram. Statistical mechanics of cellular automata. *Rev. Mod. Phys.*, 55:601–644, 1983.

