



HAL
open science

A Reciprocity Theorem for Monomer-Dimer Coverings

Nick Anzalone, John Baldwin, Ilya Bronshtein, Kyle T. Petersen

► **To cite this version:**

Nick Anzalone, John Baldwin, Ilya Bronshtein, Kyle T. Petersen. A Reciprocity Theorem for Monomer-Dimer Coverings. Discrete Models for Complex Systems, DMCS'03, 2003, Lyon, France. pp.179-194, 10.46298/dmtcs.2305 . hal-01183312

HAL Id: hal-01183312

<https://inria.hal.science/hal-01183312>

Submitted on 12 Aug 2015

HAL is a multi-disciplinary open access archive for the deposit and dissemination of scientific research documents, whether they are published or not. The documents may come from teaching and research institutions in France or abroad, or from public or private research centers.

L'archive ouverte pluridisciplinaire **HAL**, est destinée au dépôt et à la diffusion de documents scientifiques de niveau recherche, publiés ou non, émanant des établissements d'enseignement et de recherche français ou étrangers, des laboratoires publics ou privés.

A Reciprocity Theorem for Monomer-Dimer Coverings

Nick Anzalone¹ and John Baldwin² and Ilya Bronshtein³ and T. Kyle Petersen⁴

¹University of Massachusetts-Boston, Boston, MA, USA, njanzalo@cs.umb.edu

²Harvard University, Cambridge, MA, USA, jbaldwin@fas.harvard.edu

³Brandeis University, Waltham, MA, USA, ilyabron@brandeis.edu

⁴Department of Mathematics, Brandeis University, Waltham, MA, USA, tkpeters@brandeis.edu

The problem of counting monomer-dimer coverings of a lattice is a longstanding problem in statistical mechanics. It has only been exactly solved for the special case of dimer coverings in two dimensions ((Kas61), (TF61)). In earlier work, Stanley (Sta85) proved a reciprocity principle governing the number $N(m, n)$ of dimer coverings of an m by n rectangular grid (also known as perfect matchings), where m is fixed and n is allowed to vary. As reinterpreted by Propp (Pro01), Stanley's result concerns the unique way of extending $N(m, n)$ to $n < 0$ so that the resulting bi-infinite sequence, $N(m, n)$ for $n \in \mathbb{Z}$, satisfies a linear recurrence relation with constant coefficients. In particular, Stanley shows that $N(m, n)$ is always an integer satisfying the relation $N(m, -2 - n) = \epsilon_{m,n} N(m, n)$ where $\epsilon_{m,n} = 1$ unless $m \equiv 2 \pmod{4}$ and n is odd, in which case $\epsilon_{m,n} = -1$. Furthermore, Propp's method was applicable to higher-dimensional cases. This paper discusses similar investigations of the numbers $M(m, n)$, of monomer-dimer coverings, or equivalently (not necessarily perfect) matchings of an m by n rectangular grid. We show that for each fixed m there is a unique way of extending $M(m, n)$ to $n < 0$ so that the resulting bi-infinite sequence, $M(m, n)$ for $n \in \mathbb{Z}$, satisfies a linear recurrence relation with constant coefficients. We show that $M(m, n)$, *a priori* a rational number, is always an integer, using a generalization of the combinatorial model offered by Propp. Lastly, we give a new statement of reciprocity in terms of multivariate generating functions from which Stanley's result follows.

Keywords: reciprocity, monomer-dimer coverings, linear recurrences

1 Introduction

1.1 Background

The problem of counting the number of monomer-dimer coverings of a lattice has been examined for many years in the field of statistical mechanics (see (KRS96)), and has applications in biology, chemistry and physics. The closely related dimer problem, where the number of monomers is zero, was exactly solved for two dimensional lattices by Kasteleyn (Kas61) and Temperley and Fisher (TF61). While we cannot offer an exact solution to the monomer-dimer problem, we can express a symmetry relationship between the numbers of coverings of certain families of lattices; the base case being a rectangular grid of

fixed height and varying width. Our results are not limited to two dimensions, however our families are classified by their growth in only one dimension.

In particular, we consider families of lattices indexed by the natural numbers ($n = 1, 2, 3, \dots$), and count the numbers, a_n , of monomer-dimer coverings on the lattices. The numbers a_n satisfy a linear recurrence which we can use to compute the numbers $a_0, a_{-1}, a_{-2}, \dots$. Surprisingly, we find that the new numbers are related, term by term, to the original sequence of numbers; for instance $a_n \sim a_{-n-2}$. Richard Stanley's book (Sta97), in the context of rational generating functions, devotes an entire section to exploring the relationships (called *reciprocity* relationships) between positively- and nonpositively-indexed terms of a sequence. The nonpositively-indexed terms may even have a nice combinatorial meaning on their own, as seen in the case of Ehrhart reciprocity, for example.[†] In this paper we describe a relationship between terms of certain integer sequences $\{a_n\}$, $n \in \mathbb{Z}$, as well as give a combinatorial interpretation to the non-natural terms.

1.2 The Problem

Rather than use the language of statistical mechanics (monomers and dimers on lattices), we will refer to matchings of graphs where we define a *matching* of a graph $G = (V, E)$ to be a collection of edges of G , no two of which share a vertex, and all the vertices that are not incident with those edges.[‡] Edges correspond to dimers, isolated vertices correspond to monomers. A matching is called *perfect* if it is composed entirely of edges, as in the dimer problem. If we consider the number of matchings of a rectangular grid-graph of fixed height m , and varying width n , we obtain an integer sequence, $\{a_n\}$. For example, when $m = 1$, we obtain the Fibonacci sequence:

$$1, 2, 3, 5, 8, \dots$$

This sequence satisfies a linear recurrence, namely $a_n = a_{n-1} + a_{n-2}$. So we can always obtain the value of a term based on the two terms to the left of it. But similarly, we can obtain the value of a term by the two terms to the right of it, e.g. $3 = 8 - 5$, or $a_n = a_{n+2} - a_{n+1}$. In this way we can extend the Fibonacci sequence to the left and get values for a_n when $n \leq 0$:

$$\dots - 8, 5, -3, 2, -1, 1, 0, 1, 1, 2, 3, 5, 8, \dots$$

So we see that we now have a doubly infinite integer sequence, and that it is symmetric up to sign, i.e. $a_n = \pm a_{-n-2}$. Some natural questions arise: Does this symmetry mean something? Do the values of a_n for $n < 0$, being integers, count something? If so, can we extend the result to larger values of m ?

The answer to all the questions is yes. In (Pro01), Propp considered integer sequences $N(m, n)$, generated by perfect matchings of rectangular grid graphs of fixed height, and how they extend to values for $n < 0$.[§] He came up with a unified combinatorial object and a way of counting signed matchings of these objects that allowed him to show that any half-infinite sequence given by the number of perfect matchings of a fixed-height grid graph extends to a bi-infinite sequence that does three things:

- It satisfies a linear recurrence relation of finite degree with constant coefficients.

[†] Ehrhart reciprocity describes a relationship between the number of lattice points found in a rational polytope, and the number of lattice points found in its interior. See (Sta97)

[‡] Another equivalent terminology would be to speak of tilings of planar regions where the tile set consists of a domino (2 by 1 rectangle) and a square (1 by 1 rectangle).

[§] His first nontrivial case, $N(2, n)$ is also the Fibonacci sequence.

- The numbers obtained when going backwards are unique and are always integers.
- The bi-infinite sequences have a special kind of symmetry, or *reciprocity*, stated roughly as $|N(m, n)| = |N(m, -n - 2)|$ for any $m > 0$.

Matchings in general (of the graphs we will classify) satisfy the same sort of linear recurrence (as we will explain in section 3). But even given that a covering problem satisfies a linear recurrence, integrality is not ensured when running the recurrence backwards.[¶] For a simple example, consider covering a 2-by- n grid with monomers and dimers, but only allow the dimers to be vertical. The number of such coverings is governed by

$$a_n = 2a_{n-1}.$$

Upon observing that $a_1 = 2$, we can generate the half-infinite sequence

$$2, 4, 8, 16, \dots$$

To work the sequence backwards, we invert the recurrence:

$$a_n = \frac{1}{2}a_{n+1}$$

to generate the bi-infinite sequence

$$\dots \frac{1}{8}, \frac{1}{4}, \frac{1}{2}, 1, 2, 4, 8, \dots$$

For $n = -1$ we cease to observe integrality. However in the case of monomer-dimer tilings, we can guarantee integrality of the sequences by showing they can be generated by counting matchings of certain graphs for *all* values of n .

The objects we will present not only ensure integrality, but also give a direct proof of the paper’s main idea: a reciprocity statement for general matchings. This claim would appear to be the least obvious judging by the numerical evidence. Indeed, consider the integer sequence $M(2, n)$, the number of matchings of a 2-by- n rectangular grid graph. The sequence is governed by the recurrence

$$M(2, n) = 3M(2, n - 1) + M(2, n - 2) - M(2, n - 3)$$

with initial ‘natural’ values $M(2, 1) = 2$, $M(2, 2) = 7$, and $M(2, 3) = 22$, allowing us to generate the bi-infinite sequence

$$\dots 14, 11, 2, 3, 0, 1, 0, 1, 2, 7, 22, 71, 228, \dots$$

Although we get integers when going backwards, we seem to lack the symmetry that Stanley and Propp observed for perfect matchings. However section 4 will reveal that there is a symmetry hidden in these numbers.

Why there should be symmetry in integer sequences as above is explained in the answer to the question: what do the numbers, $M(m, n)$ for $n < 0$, count? Propp had an answer for the case of perfect matchings, but it doesn’t directly translate to general matchings. Section 2 outlines the dilemma and gives a solution

[¶] *A priori* the numbers obtained from running a linear recurrence in reverse need only be rational. If the recurrence is of the form $a_n = c_1 a_{n-1} + c_2 a_{n-2} + \dots + c_k a_{n-k}$, then to push the sequence backwards we solve for the smallest term to get $a_{n-k} = \frac{a_n - c_1 a_{n-1} - \dots - c_{k-1} a_{n-k+1}}{c_k}$.

by way of objects called “empty vertices”. In Propp’s article (Pro01), weights were not given to isolated vertices, simply because there were none. But when examining matchings as we’ve defined them (a monomer-dimer model), isolated vertices do have weights, giving rise to the need for empty vertices to explain the observed phenomenon and tell the “proper” combinatorial story. By incorporating empty vertices we will obtain a combinatorial model whose number of *signed* matchings is $M(m, n)$ for all n . Looking at the signed matchings we can see the symmetry hidden in the terms above:

$$\dots 121 - 107, 41 - 30, 12 - 10, 5 - 2, 1 - 1, 1, 0, 1, 1 + 1, 5 + 2, 12 + 10, 41 + 30, 121 + 107, \dots$$

The properties exhibited by the numbers $M(m, n)$ and the objects they count can also be seen in terms of the generating function $F_m(t, x, y, z) = \sum_{n=1}^{\infty} f_n(x, y, z)t^n$. Here x is the weight given to horizontal edges, y is the weight given to vertical edges, and z is the weight given to vertices. The polynomial $f_n(x, y, z)$ encodes all of the matchings of an m by n grid graph. We will show

1. $F_m(t, 1, 1, 1) = \sum_{n=1}^{\infty} M(m, n)t^n$
2. $F_m(t, 1, 1, 0) = \sum_{n=1}^{\infty} N(m, n)t^n$
3. $F_m(t, x, y, z) \sim -F_m(1/t, x, -y, -z)$

The second item in the list shows how perfect matchings may be extracted from general matchings. The last item in the list is a heuristic expression of reciprocity that will be made precise in section 4.2.

The theory of empty vertices is applicable to more general situations than simply matchings of rectangular grid graphs. We will prove results for matchings of graphs of the form $G \times P_n$, where G is an arbitrary finite graph and P_n is the path graph of length n . We will refer to such graphs as “generalized rectangles”. Notice that an m by n rectangular grid graph is $G \times P_n$ where $G = P_m$. If $M(n)$ is the number of matchings of $G \times P_n$, we can show that there are objects whose number of matchings is $M(-n)$, i.e. a definition for $G \times P_{-n}$. By extension, this implies that the same symmetry will exist for the entire family of generalized rectangles. Throughout most of the paper, our proofs will be for generalized rectangles, but examples will usually involve grid graphs.

2 Signed Graphs and Signed Matchings

Let us try to deduce the nature of m by n rectangular grid graphs for all n , not concerning ourselves with matchings at all. In Figure 1, denote the 2 by 3 grid graph by $G(2, 3)$. The graph $G(2, 4)$ is obtained from $G(2, 3)$ by adding two horizontal edges, a vertical edge, and two vertices as shown. Likewise, we can obtain $G(2, 2)$ by removing the same set of edges and vertices from the right of $G(2, 3)$. Then we get $G(2, 1)$ and $G(2, 0)$ inductively. But what are we to make of $G(2, 0)$? It has no vertices, and two “anti-” horizontal edges. How many matchings should this have? What about $G(2, -1)$? $G(2, -2)$?

The definitions that Propp created for $G(m, n)$ with $n < 0$ look quite similar to the pictures in Figure 1, except that his horizontal lines are solid and there are vertices on the endpoints of the horizontal edges where there are none in Figure 1 (see Figure 2).

Notice that in Figure 1 the graphs for $G(2, 0)$ and $G(2, -1)$ have some horizontal edges that are incident with only one vertex. The meaning of these missing vertices, these places that are “empty” of vertices, is described below. Let $G = (V, E)$ be a graph in the usual sense, i.e. a set of vertices and edges between them, except that there is more than one kind of edge and more than one kind of vertex (see Figure 3).

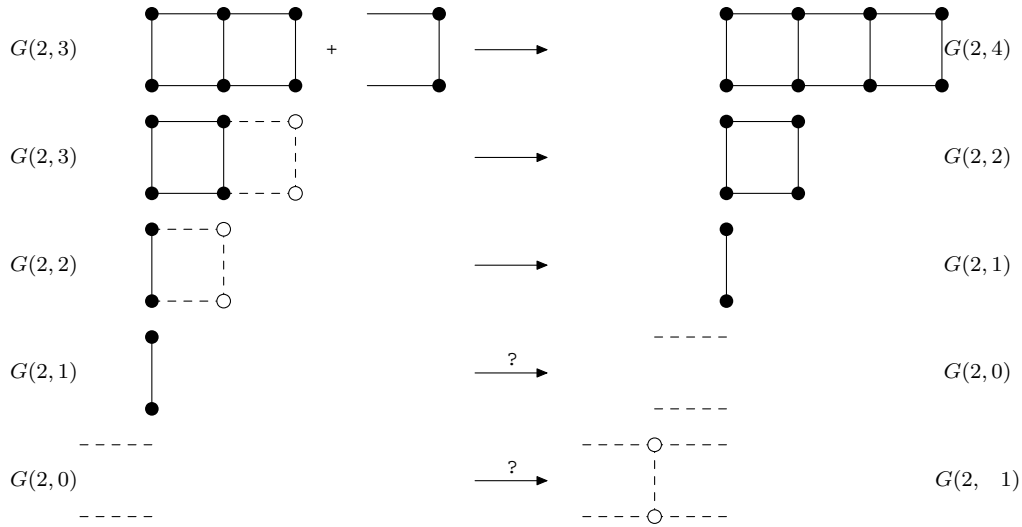

Fig. 1: Moving from $G(2,3)$ to $G(2,4)$ or $G(2,2)$

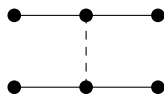

Fig. 2: Propp's model for $G(2, -1)$.

There are plain, anti-, and empty vertices, plain and anti-vertical edges (vedges), and plain horizontal edges (hedges). For now, plain components are given weight 1, anti-vertices and anti-vedges are given weight -1, and empty vertices have weight zero.^{||}

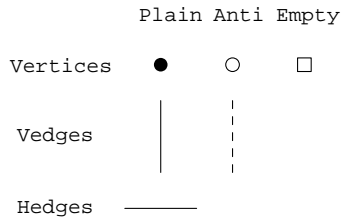

Fig. 3: Basic components of a signed graph.

Define a *signed matching* of a graph G to be a collection of non-adjacent edges of G and all the vertices not incident with those edges. The weight of the matching is the product of the weights of the components in the matching. Note that this means all the matchings with empty vertices vanish. In practice, it helps

^{||} Later we will attach formal variables to edges and vertices, but empty vertices will still have weight zero. Thinking of monomer-dimer coverings, empty vertices represent positions in the lattice that may not be occupied by a monomer.

to think of empty vertices as being *needy*. For any nonzero matching, empty vertices *need* to have one of their incident edges included.

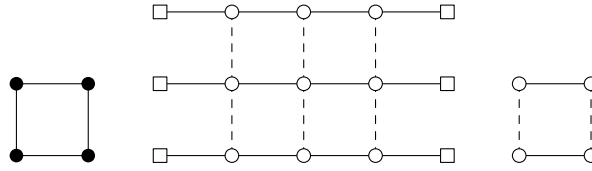

Fig. 4: Pictures of graphs $G(2,2)$, $G(3,-3)$, and $G^*(2,2)$.

Define a regular signed graph, $G(m,n) = P_m \times P_n$ in the following way. If $n > 0$, $G(m,n)$ is just a rectangular grid graph, i.e., a graph with mn plain vertices arranged into m rows of n vertices each, with plain edges adjoining horizontal and vertical neighbors. Define the conjugate graph of G , denoted G^* , to be the graph obtained by replacing all of the vertices and vedges of G with their anti-counterparts (assuming that an anti-anti-vertex is a plain vertex, etc.). Under this definition, $(G(m,n))^* = G^*(m,n)$ is a graph with mn anti-vertices arranged into m rows of n vertices with hedges adjoining horizontal neighbors and anti-vedges adjoining vertical neighbors. Then for $n \leq 0$, $G(m,n)$ is defined to be a copy of $G^*(m,n)$ with a column of m empty vertices on the left and m empty vertices on the right. Each empty vertex is connected (with a hedge) only to the anti-vertex horizontally adjacent to it (see Figure 4).

For fixed $m > 0$ and any integer n , we define the numbers $M(m,n) = M(G(m,n))$ to be the sum of the weights of the signed matchings of $G(m,n)$. In general, $M(G)$ is the sum of the weights of all of the signed matchings of G . Some examples are given in Figure 5.

Having made all our definitions in terms of rectangular grid graphs, we would now like to extend them to apply to general rectangular regions. For any finite graph G , define the generalized rectangle graph $G \times P_n$ with $n > 0$ as follows: Picture n copies of G lined up side by side. Each vertex in one copy of G is connected with an edge to its image in the copies of G to the left and right of it. Define all the edges *within* a copy of G to be vedges, and the edges *between* copies of G to be hedges. With this idea, we can define $G \times P_{-n}$ to be $G^* \times P_n$ with m ($=$ the number of vertices in G) empty vertices to the left and to the right of it. Each empty vertex is connected to exactly one of the vertices of G^* with a hedge. We shall see that these definitions are necessary to prove statements of reciprocity for more than just grid graphs.

3 Adjunction

Although it seems there are separate definitions for $G(m,n)$ (resp. $G \times P_n$) when $n > 0$ and when $n \leq 0$, we will show they are actually the same object. In Propp’s words, they fit together “seamlessly.” If they fit together this way, then it follows that for any G , the sequence $M(G \times P_n)$ satisfies a linear recurrence of finite degree with constant coefficients. We will omit the proof as it is given in (Pro01). The method of proof utilizes transfer matrix methods and the Cayley-Hamilton theorem, and it requires only that the family of graphs satisfy the property detailed below.

We begin by making a natural observation about the half-infinite sequence $M(G(m,n))$, $n > 0$, and then we will prove that it actually holds for any n . In doing so, we will be able to establish that we do indeed have an appropriate definition for $G(m,n)$ (resp. $G \times P_n$) with $n \leq 0$, and all our desires for the doubly infinite sequence—integrality, uniqueness, and reciprocity—will be fulfilled.

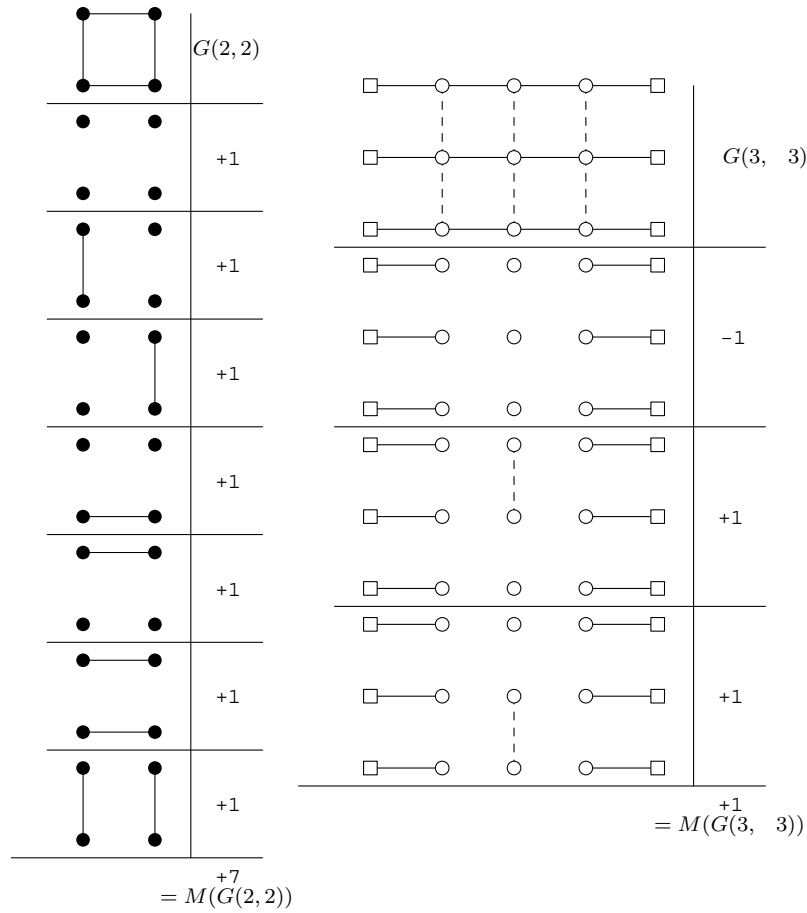

Fig. 5: Pictures of nonzero signed matchings of $G(2,2)$ and $G(3,-3)$.

We first notice that for positive n_1, n_2 , we can draw the graph $G(m, n_1 + n_2)$ by placing $G(m, n_1)$ and $G(m, n_2)$ side by side and using hedges to connect the rightmost m vertices of one to the leftmost m vertices of the other, as shown in Figure 6. Call this operation *adjunction*. Generally, define the adjunction of two graphs $H = G \times P_{n_1}, H' = G \times P_{n_2}$ to be a new graph formed by connecting H to H' with hedges, matching up corresponding vertices. In particular:

- If n_1, n_2 are positive, connect every vertex in the rightmost copy of G in H to its image in the leftmost copy of G in H' using a hedge.
- If n_1 is positive, n_2 negative, join every vertex v in the rightmost copy of G in H to an empty vertex on the left side of H' so that v is connected to v^* (the anti-vertex corresponding to v) in the leftmost copy of G^* in H' by the path hedge-empty vertex-hedge.
- If n_1, n_2 are both negative, join every vertex in the rightmost copy of G^* in H to its image in the

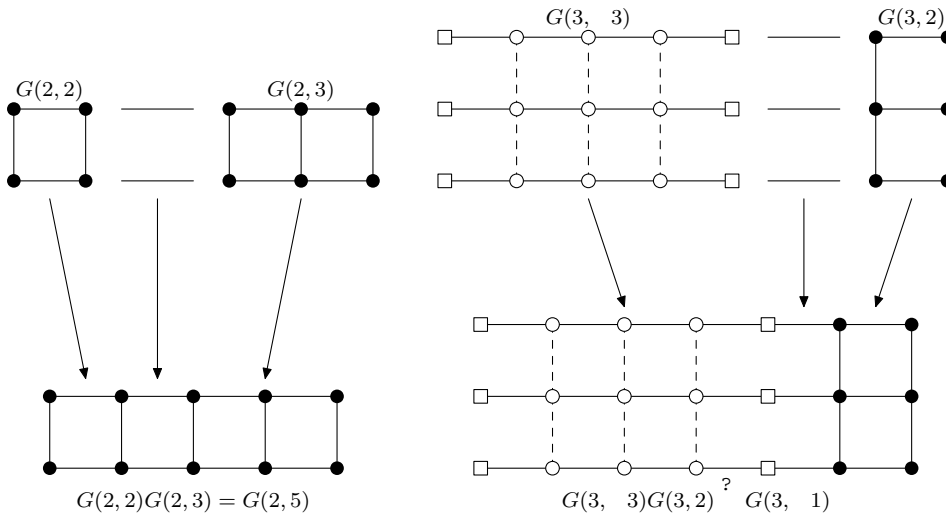

Fig. 6: Pictures of two pairs of adjoined graphs.

leftmost copy of G^* in H' by connecting their adjacent empty vertices with a hedge.

We write the adjunction of $G \times P_{n_1}$ and $G \times P_{n_2}$ as $(G \times P_{n_1})(G \times P_{n_2})$.

Returning to case of rectangular grid graphs where n_1, n_2 are positive, $G(m, n_1)G(m, n_2) = G(m, n_1 + n_2)$, and naturally, $M(G(m, n_1)G(m, n_2)) = M(G(m, n_1 + n_2))$. This is true more generally, as stated in the following:

Theorem 1 (Adjunction)

$$M((G \times P_{n_1})(G \times P_{n_2}) \cdots (G \times P_{n_k})) = M(G \times P_{n_1+n_2+\cdots+n_k})$$

for all integers n_1, \dots, n_k . In particular,

$$M(G(m, n_1)G(m, n_2) \cdots G(m, n_k)) = M(G(m, n_1 + n_2 + \cdots + n_k))$$

for all integers n_1, \dots, n_k .

The proof of Theorem 1 will require the following two lemmas.

Lemma 1 *Let G be a signed graph where two vertices, a and b , are connected by the path hedge-empty vertex-hedge-empty vertex-hedge. Then G has same number of matchings as the graph G' , where G' is identical to G except that a and b are connected with one hedge.*

Proof: The claim made by Lemma 1 is most easily seen in Figure 7 where we see the immediate bijection. When the hedge between the empty vertices is present in G , then in any matching a and b are not connected inwards. This corresponds to the case when the hedge between a and b in G' is not present.

On the other hand, any matching of G where the hedge between the empty vertices is not present forces a and b to be connected inwards. This is equivalent to the hedge between a and b being present in a matching of G' . □

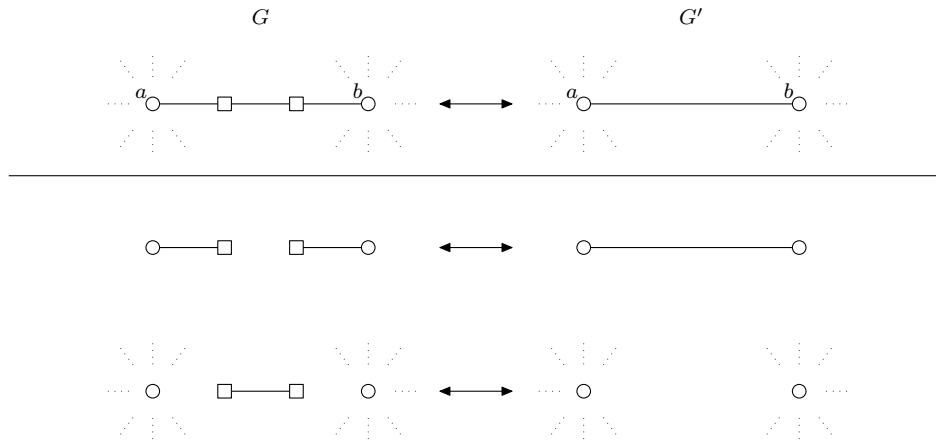

Fig. 7: Proof of bijection between G and G' in Lemma 1.

Lemma 2 Let G be a finite graph with all plain components. Then let H be the graph $(G \times P_{n_1})(G \times P_{n_2})$ for $n_1 > 0 > n_2$. Then H has the same number of signed matchings as the graph $H'=(G \times P_{n_1-1})(G \times P_{n_2+1})$.

Proof: We begin by examining what happens at each vertex, see Figure 8. Consider the plain vertex a of G connected to the anti-vertex a^* of G^* by the path hedge-empty vertex-hedge. There are essentially two types of matchings of H . We'll say type 1 matchings include the hedge connecting a to the empty vertex and type 2 matchings include the hedge connecting a^* to the empty vertex. Most of the matchings of type 1 will cancel with most of the matchings of type 2.

Given a matching of type 1, there are only three cases for what can happen the anti-vertex a^* of G^* : it can be isolated, it can have an anti-vedge incident with it, or it can have a hedge incident with it. Likewise for any matching of type 2, the vertex a can be isolated, incident with a vedge or incident with a hedge. If there are k signed matchings of type 1 where a^* is isolated, then there are $-k$ signed matchings of type 2 where a is isolated. Similar cancellation occurs between matchings of type 1 where a^* has an anti-vedge and matchings of type 2 where a has a vedge (corresponding to the anti-vedge incident with a^*).

The only remaining cases are those of type 1 and type 2 where a and a^* both have hedges. We claim that these matchings are in bijection with the graph where a, a^* , all their incident vedges, and the hedges and empty vertex between a, a^* are all replaced with one empty vertex. The correspondence is shown in Figure 8. Since a was any vertex of G , this can be done for every vertex of G and the lemma holds. \square

With the lemmas proved, Theorem 1 is not difficult to show.

Proof of Theorem 1: It is easily verified that $M((G \times R)(G \times P_n)) = M(G \times P_n)$, so we may assume all the n_i are non-zero. We have that $M((G \times P_{n_1})(G \times P_{n_2})) = M(G \times P_{n_1+n_2})$ whenever n_1 and n_2 are negative by applying Lemma 1 to each place where adjoining takes place. When $n_1 n_2 < 0$, we can apply Lemma 2 repeatedly. Upon each application of Lemma 2 we change neither the number of matchings nor the difference between the number of vertices and the number of anti-vertices. \square

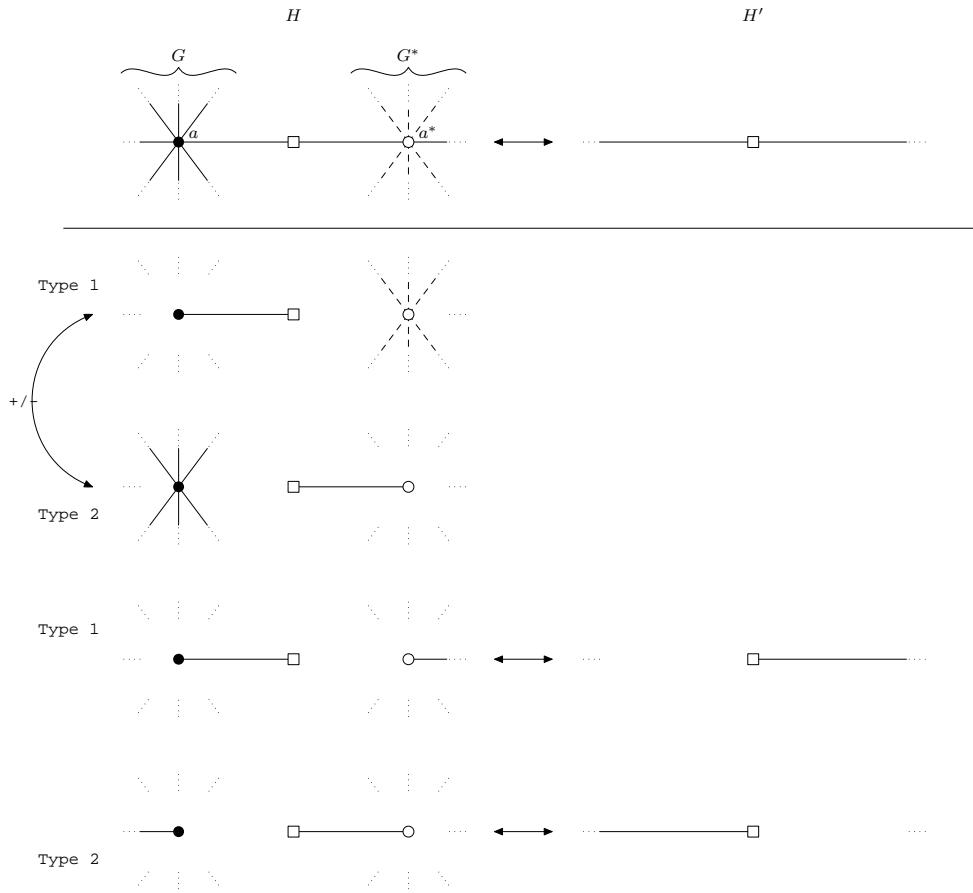

Fig. 8: Proof of Lemma 2.

4 Reciprocity

4.1 Combinatorial Reciprocity

The combinatorial statement of reciprocity is rather obvious given the definition of $G \times P_n$ for $n \leq 0$ and the neediness of empty vertices:

Theorem 2 (Reciprocity (I))

$$M(G \times P_{-n-2}) = M(G^* \times P_n).$$

In particular,

$$M(G(m, -n-2)) = M(G^*(m, n)).$$

Proof: On the left side of Figure 10 we have $G(m, -n-2)$. But since all the outside edges are forced, the number of matchings of $G(m, -n-2)$ is clearly equal to the number of matchings of $G^*(m, n)$. The situation for generalized rectangles is identical. \square

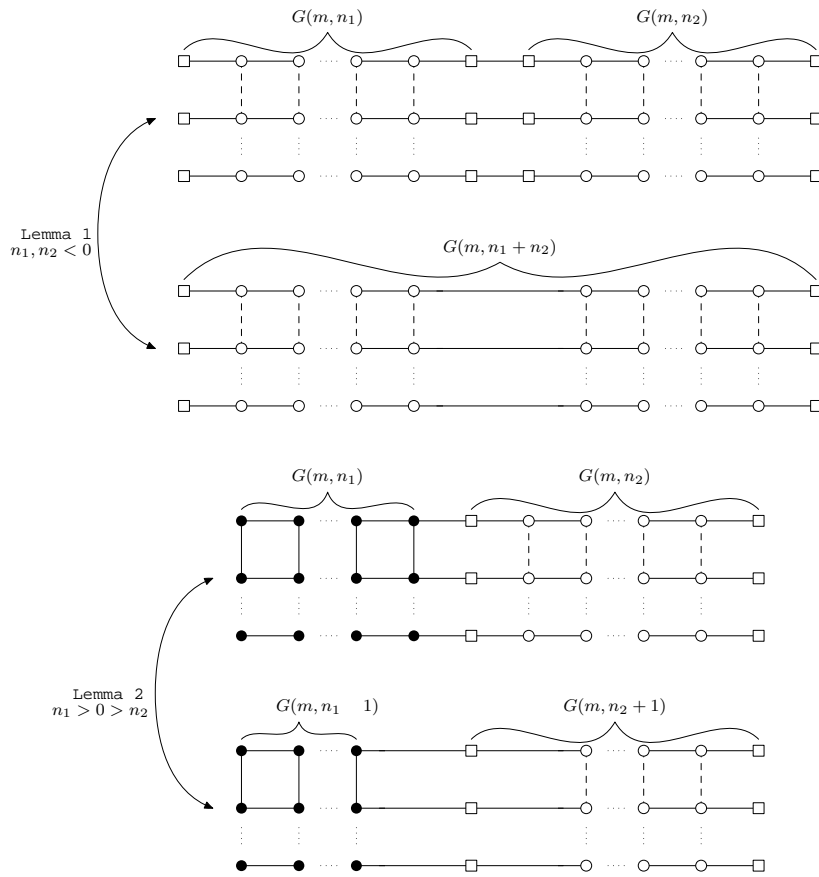

Fig. 9: Picture of Theorem 1 using lemmas.

This statement of reciprocity is the natural extension of the property of dimer coverings observed by Propp (Pro01). Indeed, if we were to consider only the perfect matchings of grid graphs, then the statement would be the same:

$$N(G(m, -n - 2)) = N(G^*(m, n)).$$

It is known that any dimer covering can be obtained from any other dimer covering by local moves that leave the parity of vedges unchanged. That is, the sign of every *perfect* matching of $G^*(m, n)$ is the same, so $|N(m, n)| = |N^*(m, n)|$. With less-than-perfect matchings, this is clearly not the case.

Perhaps the strength of this result is more obvious when we give all the edges and vertices formal weights and derive a statement of reciprocity in terms of a generating function. Though we could do so for any finite graph of the form $G \times P_n$, we will only derive an explicit formula for $G(m, n)$.

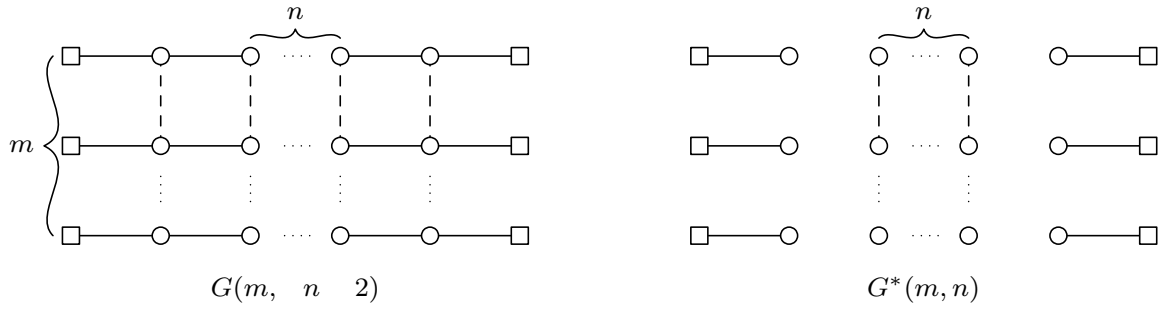

Fig. 10: Picture of Reciprocity for grid graphs.

4.2 The Generating Function

For convenience, let the weights of the vertices of $G(m, n)$ for $n > 0$ be indexed by $\mathbb{N} \times \mathbb{N}$, read from left to right and top to bottom. Notice that the top left vertex is $z_{1,1}$ and the bottom right vertex is $z_{m,n}$. Then $x_{i,j}$ is the weight given to the hedge between $z_{i,j}$ and $z_{i,j+1}$, and $y_{i,j}$ is the weight given to the vedge between $z_{i,j}$ and $z_{i+1,j}$. To get the weights for vertices of $G(m, -n)$, we begin by giving the top right anti-vertex weight $z_{1,0}$ and we proceed analogously. The weights of $G(2, 3)$ and $G(2, -5)$ are shown in Figure 11.

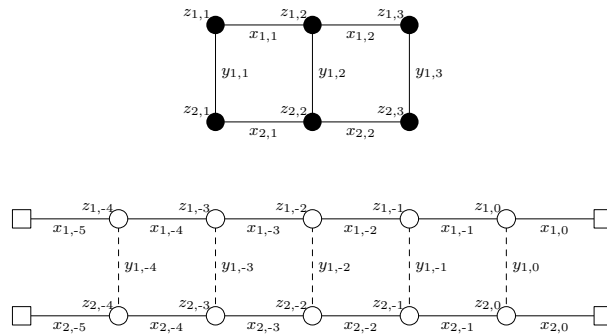

Fig. 11: Picture of graphs weighted with formal variables.

The weight of a matching with formal variables is not exactly like the weight as defined before, as is seen in the following:

Definition 1 If g is a matching of $G(m, n)$, define the weight of g , $w(g)$, as follows (where $\text{sgn}(t) = 1$ if t is positive, -1 otherwise):

$$w(g) = \frac{\left(\prod_{\text{hedges in } g} x_{i,j} \right) \left(\prod_{\text{vedges in } g} \text{sgn}(j) y_{i,j} \right) \left(\prod_{\text{vertices in } g} \text{sgn}(j) z_{i,j} \right)}{\prod_{\text{all hedges in } G(m,n)} x_{i,j}^{(1-\text{sgn}(j))/2}}$$

Notice that for $n < 0$, there is a monomial denominator in the weights of matchings. By our definition, the matchings shown in Figure 12 have weights

$$x_{1,2}y_{1,1}z_{2,2}z_{2,3} \text{ and } \frac{y_{1,-1}z_{2,-2}z_{2,-3}}{x_{1,-1}x_{1,-2}x_{1,-4}x_{2,-1}x_{2,-2}x_{2,-3}x_{2,-4}}$$

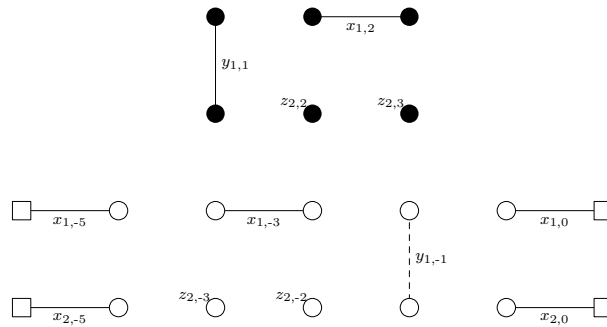

Fig. 12: Picture of matchings weighted with formal variables.

With this new definition of weights, we define the matching polynomial. In the literature, there are conventions for describing the matching polynomial of a graph. Our definition does not adhere strictly to these conventions, though it is similar to the partition function for the monomer-dimer model, with distinct formal variables for all monomers and dimers (see (HL72),(COSW02)).

Definition 2 The matching polynomial of $G(m, n)$, $f_n(x_{i,j}, y_{i,j}, z_{i,j})$, is given by

$$f_n(x_{i,j}, y_{i,j}, z_{i,j}) = \sum_{\text{all matchings of } G(m,n)} w(g)$$

where $i = 1 \dots m$, $j = 1 \dots n$ if $n > 0$, $j = 0, -1 \dots n$ if $n < 0$,

Strictly speaking, the matching polynomial is a Laurent polynomial; a polynomial in the variables $x_{i,j}, x_{i,j}^{-1}, y_{i,j}, z_{i,j}$. Notice if we set all of the weights equal to 1 we get $f_n(1, 1, 1) = M(G(m, n))$, the number of signed matchings. Similarly if we set all the $x_{i,j}, y_{i,j}$ equal to 1 but set all the $z_{i,j}$ equal to 0, then $f_n(1, 1, 0) = N(G(m, n))$, the number of signed perfect matchings.

By construction the polynomials f_n will satisfy a linear recurrence very similar to that which governs $M(G(m, n))$. For example, if $m = 1$, then we get $f_n = z_{1,n}f_{n-1} + x_{1,n-1}f_{n-2}$ for all n . Likewise, there is a link between the polynomials f_n and f_{-n-2} for $n \geq 0$, seen most easily if we let $x_{i,j} = x, y_{i,j} = y, z_{i,j} = z$ for all i, j :

$$f_n(x, -y, -z) = x^{m(n+1)}f_{-n-2}(x, y, z). \tag{1}$$

As mentioned in Section 3, for any fixed m , the numbers $M(m, n)$, $n \in \mathbb{Z}$ satisfy a linear recurrence of finite degree with constant coefficients. Therefore there is a rational generating function for the number of weighted matchings,

$$F_m(t, x, y, z) = \sum_{n \geq 0} f_n(x, y, z)t^n.$$

Given (1) it is an easy exercise (see for example (Sta97), ch. 4) to state a reciprocity theorem for the generating function:

Theorem 3 (Reciprocity(II))

$$x^m t^2 F_m(t, x, y, z) = -F_m\left(\frac{1}{tx^m}, x, -y, -z\right).$$

This completes the main goal of the paper.

5 More on Linear Recurrences and Reciprocity

Though we have only proved theorems here for graphs of the type $G \times P_n$, (cylinders of fixed circumference and varying height for example), we have also been able to use a modified form of adjunction to build a model for the honeycomb graph of fixed height and width $n \in \mathbb{Z}$. Other graphs that we examined but were unable to apply our methods include: cylinders with fixed height and varying circumference, Möbius strips, tori, and projective planes. We do however feel that there may be a way of dealing with such graphs.

In an unpublished paper (Spe02), Speyer developed a matrix method for encoding perfect matchings of a graph. With this method he was able to state theorems about recurrences and reciprocity for a broader range of graphs than those we have handled here. In particular, he was able to make a statement about the Möbius strip and projective plane. An adaptation of his method to general matchings seems promising, though experimentation has shown it to be less than straightforward.

Acknowledgements

We'd like to thank Jim Propp for introducing us to this problem and for getting us started with the early investigations. Without his REACH program to bring the authors together, this work could not have been done.

References

- [COSW02] Y.B. Choe, J.G. Oxley, A.D. Sokal, and D.G. Wagner. Homogeneous multivariate polynomials with the half-plane property. Preprint, 2002.
- [HL72] O.J. Heilmann and E.H. Lieb. Theory of monomer-dimer systems. *Comm. Math. Physics*, 25:190–232, 1972.
- [Kas61] P.W. Kasteleyn. The statistics of dimers on a lattice. *Physica*, 27:1209–1225, 1961.
- [KRS96] C. Kenyon, D. Randall, and A. Sinclair. Approximating the number of monomer-dimer coverings of a lattice. *Journal of Statistical Physics*, 83:637–659, 1996.
- [Pro01] J. Propp. A reciprocity theorem for domino tilings. *The Electronic Journal of Combinatorics*, 8:R18, 2001.
- [Spe02] D. Speyer. Unpublished note on transfer matrices, 2002.

- [Sta85] R. Stanley. On dimer coverings of rectangles of fixed width. *Disc. Appl. Math.*, 12:81–87, 1985.
- [Sta97] R. Stanley. *Enumerative Combinatorics, Volume I*. Cambridge University Press, 1997.
- [TF61] H.N.V. Temperley and M.E. Fisher. Dimer problem in statistical mechanics - an exact result. *Philosophical Magazine*, 6:1061–1063, 1961.

