



HAL
open science

Multi-Rate Mass Transfer (MRMT) models for general diffusive porosity structures

Tristan Babey, Jean-Raynald de Dreuzy, Céline Casenave

► **To cite this version:**

Tristan Babey, Jean-Raynald de Dreuzy, Céline Casenave. Multi-Rate Mass Transfer (MRMT) models for general diffusive porosity structures. *Advances in Water Resources*, 2015, 76, pp.146-156. 10.1016/j.advwatres.2014.12.006 . hal-01102049

HAL Id: hal-01102049

<https://inria.hal.science/hal-01102049>

Submitted on 12 Jan 2015

HAL is a multi-disciplinary open access archive for the deposit and dissemination of scientific research documents, whether they are published or not. The documents may come from teaching and research institutions in France or abroad, or from public or private research centers.

L'archive ouverte pluridisciplinaire **HAL**, est destinée au dépôt et à la diffusion de documents scientifiques de niveau recherche, publiés ou non, émanant des établissements d'enseignement et de recherche français ou étrangers, des laboratoires publics ou privés.

1 Multi-Rate Mass Transfer (MRMT) models for general 2 diffusive porosity structures

3 Tristan Babey¹, Jean-Raynald de Dreuzy¹, Céline Casenave^{2,3}

4 ¹Géosciences Rennes (UMR CNRS 6118), Campus de Beaulieu, Université de Rennes 1,
5 35042 Rennes cedex, France

6 ²UMR INRA-SupAgro 0729 MISTEA, 2 place Viala 34060 Montpellier, France

7 ³MODEMIC project-team, INRA/INRIA, Sophia-Antipolis, France

8 Corresponding author: Tristan Babey, +33646204318, tristan.babey@univ-rennes1.fr

9 Highlights:

- 10 • A mobile-immobile transport model with a structured immobile domain is proposed
- 11 • Structured INteracting Continua-SINC generalize Multiple INteracting Continua-
12 MINC
- 13 • Whatever the SINC structure, a unique equivalent MRMT model exists
- 14 • MRMT models with only very few rates accurately model conservative transport
- 15 • We propose a robust numerical identification of the first few rates

16 **ABSTRACT**

17 We determine the relevance of Multi-Rate Mass Transfer (MRMT) models to general diffusive
18 porosity structures. To this end, we introduce Structured INteracting Continua models (SINC)
19 as the combination of a finite number of diffusion-dominated interconnected immobile zones
20 exchanging with an advection-dominated mobile domain. It directly extends Multiple
21 INteracting Continua framework [*Pruess and Narasimhan, 1985*] by introducing a structure in
22 the immobile domain, coming for example from the dead-ends of fracture clusters or poorly-
23 connected dissolution patterns. We demonstrate that, whatever their structure, SINC models
24 can be made equivalent in terms of concentration in the mobile zone to a unique Multi-Rate
25 Mass Transfer (MRMT) model [*Haggerty and Gorelick, 1995*]. We develop effective shape-
26 free numerical methods to identify its few dominant rates, that comply with any distribution
27 of rates and porosities. We show that differences in terms of macrodispersion are not larger
28 than 50% for approximate MRMT models with only one rate (double porosity models), and
29 drop down to less than 0.1% for five rates MRMT models. Low-dimensional MRMT models

30 accurately approach transport in structured diffusive porosities at intermediate and long times
31 and only miss early responses.

32

33 Keywords: Porous media; Solute transport; Mobile-immobile models; Multi-Rate Mass
34 Transfer;

35 1 Introduction

36 Transport in complex geological environments results in part from the interactions between
37 fast advective-dominated transport in a localized "mobile porosity" and slow diffusive-
38 dominated transport in extensive "immobile porosities". It is the case of the fracture-matrix
39 systems [Neretnieks, 1980; Tang *et al.*, 1981] and of the highly heterogeneous porous media
40 [Fernandez-Garcia *et al.*, 2009; Golfier *et al.*, 2007; Gotovac *et al.*, 2009; Willmann *et al.*,
41 2008]. When diffusive times in the immobile zones become much larger than the
42 characteristic advective time in the mobile zone, transport becomes anomalous with non-
43 Gaussian concentration plumes, more extensive spreading and mixing, slow transit times, and
44 broad ranges of solute retardation times [Berkowitz *et al.*, 2006; Dentz *et al.*, 2004]. Such
45 transport mechanisms and exchanges are at the root of numerous anomalous transport
46 modeling frameworks [Benson and Meerschaert, 2009; Benson *et al.*, 2000; Berkowitz and
47 Scher, 1998; Carrera *et al.*, 1998; Cushman and Ginn, 2000; Haggerty and Gorelick, 1995]
48 and can be highly effective in the interpretative and predictive phases of laboratory and field
49 experiments [Benson *et al.*, 2001; Berkowitz *et al.*, 2000; Gouze *et al.*, 2008; Haggerty *et al.*,
50 2001; Haggerty *et al.*, 2004]. Anomalous transport ultimately stems from some extended
51 distribution whether it is a waiting time distribution as in Continuous Time Random Walk
52 (CTRW) or a rate-porosity distribution as in Mutli-Rate Mass Transfert (MRMT) [Dentz and
53 Berkowitz, 2003; Neuman and Tartakovsky, 2009; Silva *et al.*, 2009]. For MRMT models,
54 while these distributions can take very different shapes [Haggerty *et al.*, 2000], only some
55 power-law distributions are effectively related to diffusive processes in 1D, 2D or 3D
56 inclusions [Carrera *et al.*, 1998; Haggerty and Gorelick, 1995] or to anomalous diffusive
57 processes in fractal-like structures [Haggerty, 2001]. Diffusive structures may however be
58 topologically more complex like for example for fracture dead ends [Flekkøy *et al.*, 2002;
59 Sornette *et al.*, 1993], fracture-matrix interactions [Jardine *et al.*, 1999; Karimi-Fard *et al.*,
60 2006; Sudicky and Frind, 1982; Tang *et al.*, 1981; Tsang, 1995], or dissolution patterns in
61 porous media [Golfier *et al.*, 2002; Luquot *et al.*, 2014] (Figure 1).

62 In this article, we show that the MRMT framework is general to all diffusive architectures that
63 can be modeled as a finite number of interconnected continua (Figure 1). The notion of
64 continuum comes from the double porosity and Multiple INteracting Continua (MINC)
65 concepts introduced initially for fracture-matrix systems [Pruess and Narasimhan, 1985;
66 Warren *et al.*, 1963]. The double porosity model is the classical diffusive interaction of
67 advective-diffusive processes in a mobile zone with a single immobile zone like in double-

68 porosity models [Warren *et al.*, 1963]. The Multiple INteracting Continua (MINC) framework
69 models matrix diffusion as diffusive-like exchanges within a succession of "continua",
70 identified to the elementary cells issued by a finite-difference discretization of the diffusion
71 process in the matrix (Figure 2a) [Pruess, 1992; Pruess and Narasimhan, 1985]. The
72 denomination of multiple continua is a direct generalization of the double porosity concept of
73 Warren and Root [1963]. We propose to further generalize the notion of interacting continua
74 to any immobile zones structure where diffusive-like exchanges intervene between any
75 connected zones or continua. Because of the potential importance of structure on diffusion,
76 we denote these models as Structured INteracting Continua (SINC). SINC models include a
77 wide range of structures going from elementary branching and loops (Figure 2b and c) to
78 more involved dissolution patterns (Figure 2d). They would typically be derived from the
79 coarse discretization of diffusion processes in dead-end porosity structures [Gouze *et al.*,
80 2008; Noetinger and Estebenet, 2000]. We define SINC models in section 2, with their exact
81 relation to the MRMT and MINC models. We show in section 3 that any SINC model is
82 equivalent in terms of transport to a unique MRMT model of the same dimension, i.e. with the
83 same number of immobile zones. We develop efficient numerical methods in section 4 to
84 identify lower-dimension but highly accurate approximate MRMT models.

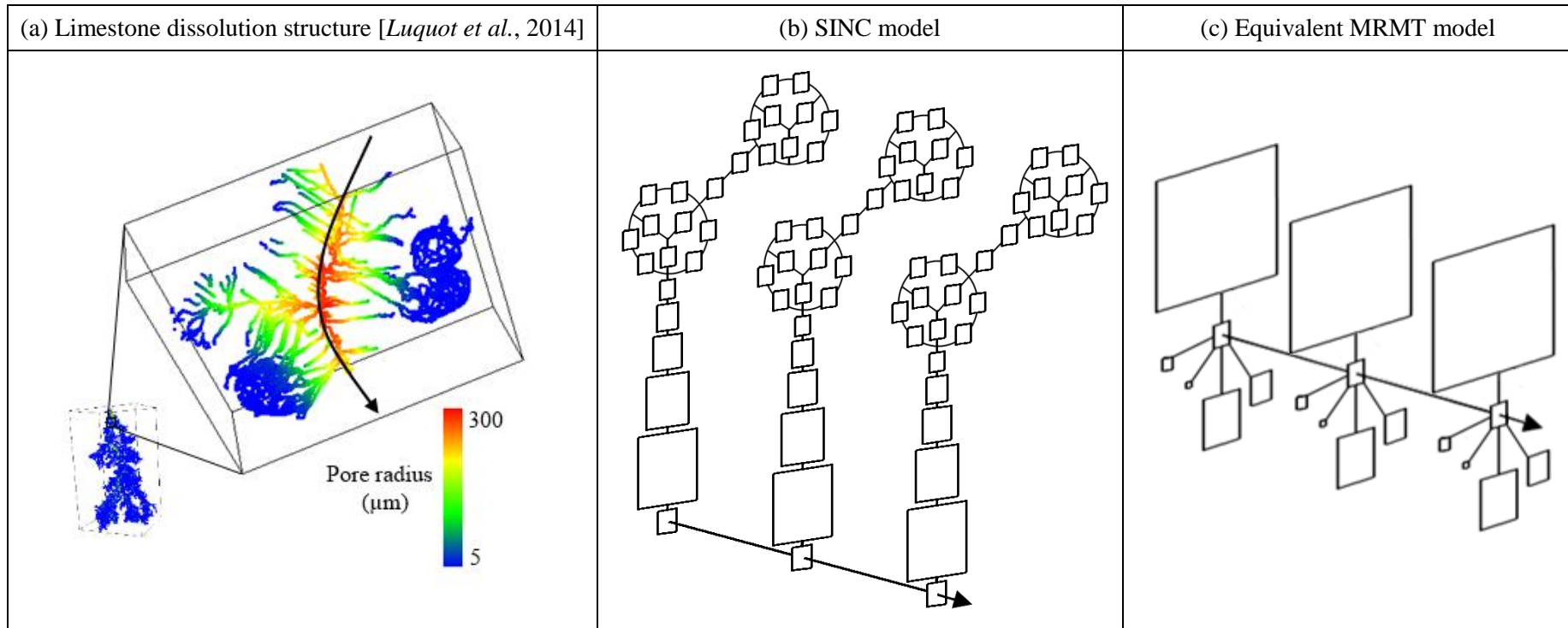

85 Figure 1: (a) Skeleton of a dissolution feature in an oolitic limestone, observed by X-ray micro-tomography [Luquot et al., 2014]. The dissolving
86 acidic solution percolates from top to bottom on the general view (bottom left). Its pH increases from top to bottom and from inside out of the
87 main flow path indicated by the curved arrow on the detailed view (top right). The acid dissolves preferentially the calcite cement surrounding
88 the oolites, the size of the pores progressively decreases away from the main flow path, and the organization of the pores becomes more complex.
89 (b) Structured INteracting Continua model (SINC) sketched from the dissolution pattern of (a) with three cross sections transversal to the mobile
90 zone materialized by the arrow. (c) Equivalent MRMT model with the 5 most important rates as determined by the numerical methods set up in
91 section 4. The size of the boxes scales with the porosity affected to the rates labeled by triangles in Figure 7.

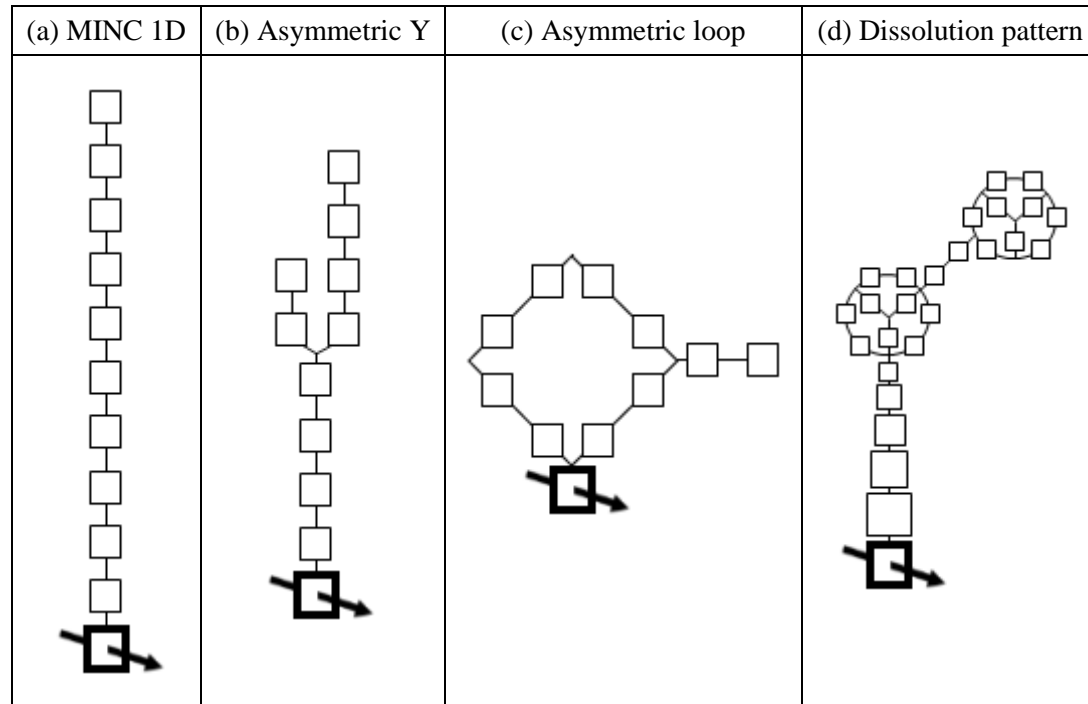

93 Figure 2: Examples of Structured Interacting Continua (SINC) used to illustrate and validate the numerical identification methods of the
94 equivalent MRMT models. From left to right, the diffusive porosity structures are (a) the classical Multiple Interacting Continua (MINC)
95 [Pruess and Narasimhan, 1985], (b) an asymmetric Y with a single junction, (c) an asymmetric loop, and (d) the dissolution structure presented
96 in Figure 1. The size of the immobile cells is proportional to their porosity and the distance along the immobile structure is to scale. The mobile
97 zone is represented by the thick black box with the crossing arrow. Its size has been exaggerated 10 times to be clearly marked. To be
98 comparable, the four structures have the same total porous volume and the same radius of gyration taken with respect to the mobile zone.

100 **2 Structured INteracting Continua (SINC)**

101 We present the Structured INteracting Continua framework (SINC) and show how it relates to
 102 existing models like Multi-Rate Mass Transfer (MRMT) and Multiple INteracting Continua
 103 (MINC).

104 The SINC model is made up of a continuous 1-D mobile zone in interaction with a finite
 105 number of interconnected immobile zones (Figure 1). In the continuous mobile zone, solutes
 106 are transported by advection, dispersion and diffusion. Between the mobile zone and the
 107 immobile zones as well as between the immobile zones, concentration exchanges are
 108 diffusive-like, i.e. directly proportional to the difference of concentrations. This model can be
 109 generically expressed as:

$$\frac{\partial U}{\partial t} - AU = L(R_m U) \quad (1)$$

110 where $U = [c_m(x, t) \ c_{im}^1(x, t) \ \dots \ c_{im}^N(x, t)]^T$ is the vector of dimension $N+1$ made up of the
 111 concentrations in the mobile zone $c_m(x, t)$ and in the N immobile zones $c_{im}^i(x, t)$ with
 112 $i=1, \dots, N$. A is the $(N+1, N+1)$ interaction matrix characterizing the diffusive-like
 113 concentration exchanges between the immobile zones and with the mobile zone. R_m is the
 114 restriction matrix to the mobile zone:

$$R_m(i, j) = \delta(i-1)\delta(j-1). \quad (2)$$

115 L is the transport operator in the mobile zone:

$$L(c_m) = -\frac{q}{\phi_m} \frac{\partial c_m}{\partial x} + d_m \frac{\partial^2 c_m}{\partial x^2} \quad (3)$$

116 with q , ϕ_m and d_m the Darcy flow, porosity and dispersion coefficient in the mobile zone.
 117 The physical properties of the mobile and immobile domains are homogeneous along the
 118 mobile domain. The interaction matrix A is equal to the matrix M deriving from the diffusive-
 119 like mass exchanges between the different zones, corrected by their porosities:

$$A = -\Phi^{-1}M \quad (4)$$

120 with Φ the diagonal matrix whose diagonal elements are the porosities associated to the
 121 mobile zone ϕ_m and to the N immobile zones ϕ_{im}^i with $i = 1, \dots, N$:

$$\begin{cases} \Phi(1,1) = \phi_m \\ \Phi(i, j) = \phi_{im}^{i-1} \delta(i, j) \text{ for } (i, j) \neq (1,1) \end{cases} \quad (5)$$

122 The matrix M expresses rates of mass exchange. The dimension of its elements is therefore
 123 the inverse of a time. As exchanges are diffusive-like, M is a M-matrix, i.e. M is symmetric,
 124 its diagonal elements are positive, its off-diagonal elements are negative or equal to zero, and
 125 the sum of its elements along each of its rows is equal to zero. We underline that it is the
 126 matrix M that is symmetric and generally not the interaction matrix A that also integrates the
 127 differences in porosities. The interaction matrix A registers the connectivity of the different
 128 zones through the position of its non-zero off-diagonal elements, the strength of the
 129 interactions is determined by porosity ratios and exchange rates. Figure 3a shows the example
 130 of the interaction matrix for the asymmetric Y structure (cf Figure 2b). The branching
 131 architecture leads to a compact interaction matrix, which values are all on the three principal
 132 diagonals except at the branching node. The interaction matrix is scaled by the inverse of the
 133 mean diffusion time in the immobile structure τ . We define τ as the quadratic mean distance
 134 of the immobile zones to the mobile zone divided by the diffusion coefficient between two
 135 zones.

136 The SINC framework generalizes Multiple INteracting Continua (MINC) [*Pruess and*
 137 *Narasimhan*, 1985]. MINC models are obtained by the finite-difference discretization of
 138 diffusion in a 1-D homogeneous medium. In such a case, the interaction matrix A is simply
 139 tri-diagonal. The term "continuum" comes from the continuity along the mobile zone like in
 140 the dual-porosity concept [*Warren et al.*, 1963]. It is consistent with our concept of a
 141 continuous formalism of transport along the mobile zone and a finite number of interacting
 142 continua in the immobile direction.

143 The SINC framework also generalizes Multiple-Rate Mass Transfer models with a finite
 144 number of rates [*Carrera et al.*, 1998; *Haggerty and Gorelick*, 1995]. In MRMT models as
 145 defined by *Haggerty et al.* [1995], the immobile domain consists in a distribution of sub-
 146 domains exchanging exclusively with the mobile domain. The star-like connectivity structure
 147 leads to an arrow-type broad-width interaction matrix (Figure 3b). Each sub-domain is
 148 characterized by its rate of transfer α_i and its porosity ϕ_{im}^i , with $\alpha_i < \alpha_{i+1}$ [*Haggerty and*

149 *Gorelick, 1995*]. When defined with a finite number of rates, MRMT models can be recovered
 150 by fixing

$$\begin{cases} M(i, j) = 0 & \text{for } i > 1, j > 1 \text{ and } i \neq j \\ M(i, 1) = M(1, i) = -\phi_{im}^{i-1} \alpha_{i-1} & \text{for } i > 1 \\ M(i, i) = -\sum_{j, j \neq i} M(i, j) & \end{cases} . \quad (6)$$

$$\begin{cases} \Phi(1, 1) = \phi_m \\ \Phi(i, j) = \phi_{im}^{i-1} \delta(i, j) & \text{for } (i, j) \neq (1, 1) \end{cases}$$

151 Because they are defined in algebraic terms, SINC models can only represent MRMT models
 152 with finite number of rates. They are rigorously not equivalent to 1D, 2D and 3D diffusion
 153 models that themselves correspond to an infinite number of exchange rates [*Haggerty and*
 154 *Gorelick, 1995*]. However they offer very accurate approximations when taking only a finite
 155 number of rates, especially as the porosities ϕ_{im}^i decrease as a power law of i . SINC models
 156 generalize MRMT models defined with a finite number of rates but remain different to
 157 MRMT models defined by an infinite serie of rates or by a continuous rate-porosity function.
 158 Our objective in this article is not to produce any kind of generalization of MRMT models but
 159 rather to determine how complex diffusive porosity structures can be approached by simpler
 160 reduced models.

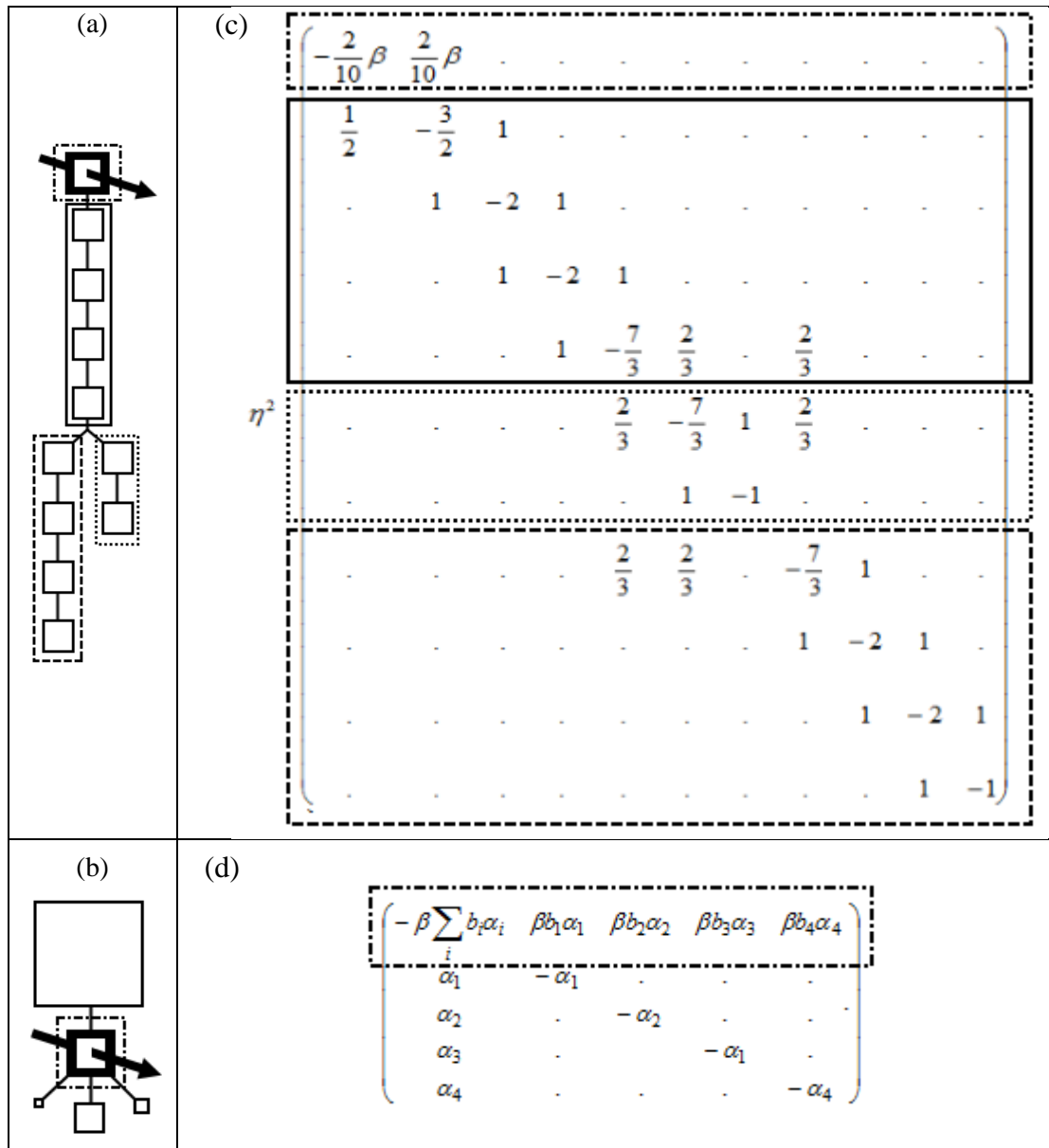

161 Figure 3: Diffusive porosity structures represented as cross-sections transversal to the mobile
 162 zone direction ((a),(b)), with their associated interaction matrix A ((c),(d)) for the asymmetric
 163 Y (*top*) and MRMT structures (*bottom*). Dotted frames around subsets of the immobile
 164 porosity structures ((a) and (b)) and around matrix lines ((c) and (d)) show how structures are
 165 translated in matrix form. Parameters for the asymmetric Y structure are taken from Table 1
 166 and the multiplicative factor η ($\eta=5.015$) is equal to the ratio of the distance between two
 167 consecutive immobile zones to the radius of gyration of the immobile domain to the mobile
 168 zone. β is the ratio of the total immobile porosity to the mobile porosity.

169 **3 Proof of equivalence of SINC to MRMT model**

170 Following up the work of *Haggerty and Gorelick* [1995], we define the equivalence relation
 171 to a MRMT model as the identity of the mobile concentration at any time. To prove the
 172 equivalence of the SINC model to a MRMT model, we first decompose the interaction matrix
 173 A in two parts, consisting in the exchanges between the immobile zones only for the first part
 174 and in the exchanges between the mobile zone and the immobile zones for the second one:

$$A = \begin{pmatrix} 0 & \cdots & \cdots & 0 \\ \vdots & & \widehat{A} & \\ \vdots & & & \\ 0 & & & \end{pmatrix} + \begin{pmatrix} A_{11} & A_{12} & \cdots & A_{1,N+1} \\ A_{21} & & & \\ \vdots & & 0 & \\ A_{N+1,1} & & & \end{pmatrix} \quad (7)$$

175 with $\widehat{A} = A(2 \dots N + 1, 2 \dots N + 1)$. As shown in *Appendix A*, the matrix \widehat{A} can be diagonalized

$$\widehat{A} = \widehat{R} \Lambda \widehat{R}^{-1} \quad (8)$$

176 with Λ the diagonal matrix made up of the eigenvalues of \widehat{A} , which are all real and negative,
 177 and \widehat{R} the matrix of the eigenvectors of \widehat{A} , defined each up to a multiplicative constant. To
 178 fix the eigenvalues decomposition, as Λ is defined up to a permutation of its diagonal
 179 elements, we sort the eigenvalues according to their absolute value by increasing order
 180 $|\Lambda_{i,i}| \leq |\Lambda_{i+1,i+1}|$. In the new coordinate system defined by the eigenvectors, there are no more
 181 exchanges between the immobile zones. All exchanges are made directly between the
 182 immobile zones and the mobile zone. To characterize the precise nature and extent of these
 183 exchanges, we propagate the change of the coordinate system to the exchanges with the
 184 mobile zone

$$\begin{pmatrix} A_{11} & A_{12} & \cdots & A_{1,N+1} \\ A_{21} & & & \\ \vdots & & 0 & \\ A_{N+1,1} & & & \end{pmatrix} = R \begin{pmatrix} A_{11} & B_{12} & \cdots & B_{1,N+1} \\ B_{21} & & & \\ \vdots & & 0 & \\ B_{N+1,1} & & & \end{pmatrix} R^{-1} \quad (9)$$

185 with the $(N + 1, N + 1)$ matrix R and its inverse R^{-1} defined as

$$R = \begin{pmatrix} 1 & 0 & \cdots & 0 \\ 0 & & & \\ \vdots & \widehat{R} & & \\ 0 & & & \end{pmatrix} \text{ and } R^{-1} = \begin{pmatrix} 1 & 0 & \cdots & 0 \\ 0 & & & \\ \vdots & \widehat{R}^{-1} & & \\ 0 & & & \end{pmatrix}. \quad (10)$$

186 In this transformation, the mobile zone remains unchanged consistently with our objective to
 187 reorganize only the immobile zones without interfering with the concentration in the mobile
 188 zone. The full transformation defined by R is applied to the matrix A following its
 189 decomposition in equation (7)

$$A = R \begin{pmatrix} 0 & \cdots & \cdots & 0 \\ \vdots & & & \\ \vdots & \Lambda & & \\ 0 & & & \end{pmatrix} R^{-1} + R \begin{pmatrix} A_{11} & B_{12} & \cdots & B_{1,N+1} \\ B_{21} & & & \\ \vdots & & 0 & \\ B_{N+1,1} & & & \end{pmatrix} R^{-1} \quad (11)$$

190 which can be finally expressed by a simple factorization as

$$A = RBR^{-1} \text{ with } B = \begin{pmatrix} A_{11} & B_{12} & \cdots & B_{1,N+1} \\ B_{21} & & & \\ \vdots & & \Lambda & \\ B_{N+1,1} & & & \end{pmatrix}. \quad (12)$$

191 Finally, as the restriction matrix to the mobile zone R_m (equation (2)) commutes with R^{-1} , we
 192 can write the full model as

$$\frac{\partial R^{-1}U}{\partial t} - BR^{-1}U = L(R_m R^{-1}U). \quad (13)$$

193 To be representative of a MRMT model, B should be an arrow matrix, the sum of its elements
 194 over each of its rows should be zero, and all its non-diagonal elements must be either positive
 195 or equal to zero. In *Appendix B*, we show that this can be obtained by adjusting the norm of
 196 the eigenvectors in \widehat{R} . The characteristics of this MRMT model are then determined by a
 197 simple identification of equation (6) with equation (12):

$$\begin{cases} \alpha_i = -\Lambda_i \\ \phi_{im}^i = \phi_m \frac{B_{1,i+1}}{B_{i+1,1}} = \phi_m \frac{B_{1,i+1}}{-\Lambda_i} \end{cases} \quad (14)$$

198 While this algebraic identification method can already be widely used to determine equivalent
 199 MRMT models, it faces some numerical limitations. The diagonalization process becomes
 200 challenging when \hat{A} becomes large, limiting the range of the identification to not too
 201 complex architectures and/or coarse discretizations of the immobile domain. The immobile
 202 porosity structure may be composed of a large number of cells, while a much smaller number
 203 of rates may be necessary to get highly accurate equivalent MRMT models. To address these
 204 limitations, we propose an alternative approximate numerical identification method.

205 **4 Approximate numerical identification method of the MRMT model equivalent to a** 206 **SINC model**

207 We first develop the numerical methodology and secondly apply it to the four examples of
 208 Figure 2. Because of their widely differing structures, these four SINC examples are thought
 209 to be a good basis for testing and illustrating the numerical methods. The first one is the
 210 classical MINC taken as reference. The two next ones were chosen for their elementary
 211 branching and looping connectivity patterns (Figure 2b and c). Any more involved patterns
 212 like the dissolution pattern of Figure 2d will be some kind of combination of these elementary
 213 structures. These four examples are comparable in the sense that they have the same mobile
 214 properties, the same overall immobile to mobile porosity ratio β , and the same mean quadratic
 215 diffusion time τ as defined in section 2 (Table 1). The dispersivity in the mobile zone
 216 $d_m \bar{\gamma}(q/\phi_m)$ divided by the effective dispersivity due to the exchanges with the immobile zone
 217 defined as $\tau(q/\phi_m)$ is taken equal to $5 \cdot 10^{-5}$, i.e. much smaller than 1, so that dispersive effects
 218 come predominantly from the mobile/immobile exchanges. For the same reason, β is taken
 219 much larger than 1 ($\beta = 100$).

Parameter	Value
β	100
$d_m / (\tau(q/\phi_m)^2)$	$5 \cdot 10^{-5}$
$\sigma_0 / (q\tau/\phi_m)$	$3 \cdot 10^{-3}$
x_{\max} / σ_0	100
dx / σ_0	0.2
dt / τ	$5 \cdot 10^{-4}$

220 Table 1: Parameters used for the simulation of section 4.2 with the characteristic diffusion
221 time τ and the consecutive distance covered by advection in the mobile zone $q\tau/\phi_m$ as
222 temporal and spatial dimensional parameters. β is the immobile to mobile porosity ratio.
223 $d_m / (\tau(q/\phi_m)^2)$ is the dimensionless dispersion in the mobile zone. $\sigma_0 / (q\tau/\phi_m)$ is the
224 dimensionless standard deviation of the initial Gaussian concentration profile. x_{\max} is the
225 extension of the simulation domain in the direction of the mobile zone, dx is the spatial step
226 along the mobile zone and dt is the time step.

227 **4.1 Methodology**

228 To numerically approximate the MRMT model equivalent to a SINC model, we consider the
229 particular case of the discharge of the immobile zones to the mobile zone. The mass
230 discharged to the mobile zone from an initially homogeneous immobile concentrations c_0 is
231 fitted by a combination of exponential functions typical of the MRMT model. The residual
232 mass per unitary volume $m(t)$ in the immobile domains is fitted by its MRMT counterpart
233 $\gamma(t)$ given by:

$$\gamma(t) = \sum_{i=1}^N c_0 \phi_{im}^i \exp(-\alpha_i t) \quad (15)$$

234 where α_i and ϕ_{im}^i , $i=1\dots N$ are the N rates and immobile porosities defined in equation (6).
235 In *Appendix C*, we develop an optimization method to identify the α and ϕ_{im} series. We
236 further illustrate its application to the cases $N=1$ and $N=2$ in *Appendix D*.

237 The advantage of this method over the previous algebraic method is to be flexible in terms of
238 the number of rates N to identify. It also prioritizes the identification of the rates and
239 immobile porosities having a significant impact on transport. In the following we determine
240 the number of rates that should be identified to model accurately macrodispersive processes.

241 **4.2 Simulations and results**

242 We analyze the influence of the number of rates N on the reproduction of macrodispersion for
243 the four structures displayed in Figure 2 for N ranging from 1 to 5. Identification is performed
244 according to the methodology presented before and with a logarithmic sampling of times
245 starting at the time for which the relative mass discharge to the mobile zone is lower than 10^{-3}
246 and ending at the time for which the relative residual mass itself is lower than 10^{-4} .

247 Simulations of transport for the SINC and approximate MRMT models are further performed
248 with identical Gaussian concentration profiles in the mobile and immobile domains

$$c_m(x, t=0) = c_{im}(x, t=0) = \frac{c_{\max}}{\sigma_0 \sqrt{2\pi}} \exp\left(-\frac{(x-x_0)^2}{2\sigma_0^2}\right) \quad (16)$$

249 where x_0 , σ_0 and c_{\max} are the mean, standard deviation and maximum concentration of the
250 Gaussian profile. σ_0 is taken small enough so that the initial plume size has minor effects on
251 the overall dispersion (Table 1).

252 We compute for all models the effective dispersion coefficient D as

$$D = \frac{1}{2} \frac{d\sigma_x^2}{dt} \quad (17)$$

253 with σ_x the plume spreading

$$\sigma_x^2 = m_2 / m_0 - (m_1 / m_0)^2. \quad (18)$$

254 The spatial moments of concentration m_k are given by

$$m_k(t) = \int_{x=0}^{\infty} \sum_{i=1}^{N+1} x^k \Phi(i, i) U(x, t, i) dx. \quad (19)$$

255 We assess the quality of the MRMT model for modeling dispersion through the quadratic
 256 mean of the relative difference in effective dispersion of the SINC and MRMT models:

$$diff(D_{SINC}, D_{MRMT}) = \sqrt{\int_t \left[\frac{D_{SINC}(t) - D_{MRMT}(t)}{(D_{SINC}(t) + D_{MRMT}(t)) / 2} \right]^2 dt} / \int_t dt. \quad (20)$$

257 This criterion is sensitive to differences in dispersion on a broad time range from the initial
 258 time to the time at which dispersion becomes constant.

259 Classical numerical methods were used to solve both the exchanges within the immobile
 260 zones and the advective-dispersive transport in the mobile zone [*de Dreuzy et al.*, 2013]. They
 261 were validated on a set of immobile structures rigorously equivalent to the MINC model
 262 (Figure 4). In those cases, $diff(D_{SINC}, D_{MINC})$ was of the order of 10^{-11} and much smaller than
 263 any differences recorded in the analysis performed hereafter.

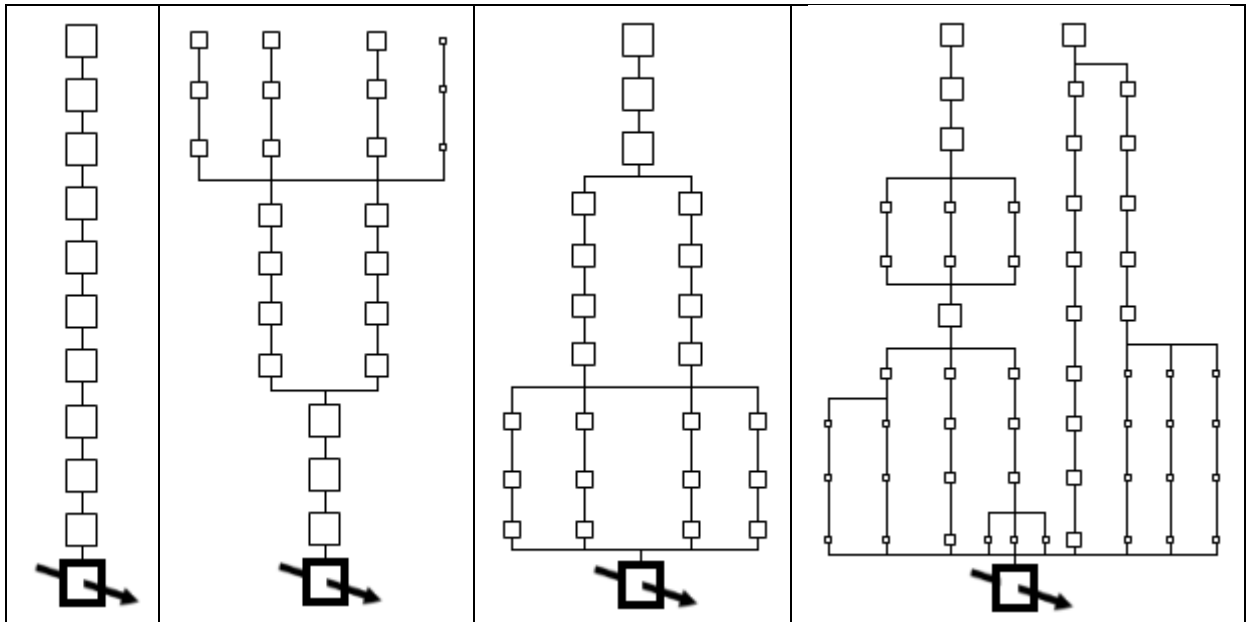

264 Figure 4: Diffusive porosity structures used to check the numerical implementation of the
 265 SINC model, equivalent to the "MINC 1D" structure (*left column*). These structures display
 266 the same behavior for homogeneous initial concentrations in the immobile zones. The mobile
 267 zone is the bold box with the arrow. The size of the boxes is proportional to the porosity of
 268 the compartments. Only the vertical distance of an immobile zone to the mobile zone is to
 269 scale.

270 For the structures displayed on Figure 2, the effective dispersion obtained with the MRMT
271 models converges quickly to the reference dispersion of the corresponding SINC model
272 (Figure 5). The equivalent MRMT model with only one immobile zone ($N=1$), equivalent to
273 the double porosity model [Warren *et al.*, 1963], already gives the right order of magnitude of
274 dispersion. With $N=2$, the error of the MRMT model is close to 10%. With $N=4$, it is close to
275 1% and with $N=5$, it is close to 0.1%. A very limited number of rates is thus sufficient to
276 represent even the complex diffusive structure displayed by Figure 2d. This fundamentally
277 comes from the homogenization nature of diffusion that systematically removes the extremes
278 of the concentration distributions as previously noted in numerous studies [Haggerty and
279 Gorelick, 1995; Villermaux, 1987].

280 In addition, the equivalent MRMT model with only one rate reproduces well the tailing of the
281 breakthrough curve (Figure 6). As expected, introducing higher rates progressively improves
282 the accuracy of the MRMT model at earlier times. The double peak observed for $N=1$ is a
283 classical feature of double porosity models where advection is much faster than diffusion in
284 the immobile porosity [Michalak and Kitanidis, 2000]. It vanishes for higher-order MRMT
285 models ($N=2$ to 5), as higher rates enhance short-term mobile-immobile exchanges and
286 remove early breakthroughs.

287 The quality of the MRMT model with only very few rates fundamentally comes from the
288 dominating role of the smaller rates (i.e. larger transfer times). In fact the whole rate series as
289 determined by the algebraic diagonalization method shows that the lowest rate dominates in
290 every case by accounting for 70% to 85% of the total immobile porosity (Figure 7). The five
291 lowest rates represent at least 95% of the total immobile porosity for all the studied structures.
292 The evolution of the porosities ϕ_{im}^i with the rates α_i is monotonic only for the MINC model
293 and becomes much more variable for more complex structures, highlighting the need of
294 identification methods that do not assume any *a priori* repartition of the immobile porosity
295 among the rates. We finally note that our results pertain to complex diffusive structures
296 observed on a given range of scales. If not close to the mobile zone, finer details would be fast
297 homogenized by diffusion and are unlikely to modify the identified rates. If close to the
298 mobile zone, finer details should be treated independently in the same way as for the larger-
299 scale structures and the MRMT models obtained at different scales should be eventually
300 superposed.

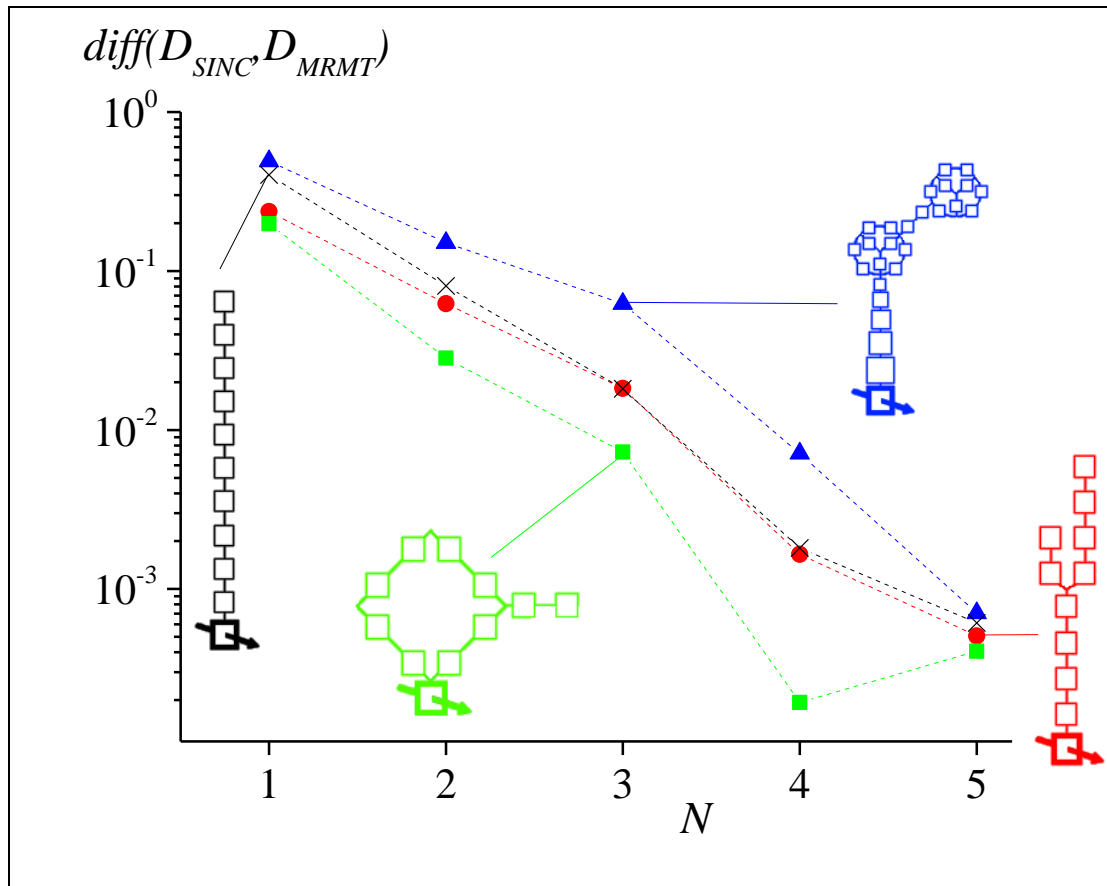

301 Figure 5: Differences in macrodispersions $diff(D_{SINC}, D_{MRMT})$ (equation (20)) between SINC
 302 models and their approximate MRMT models with a limited number of rates $N=1$ to 5, for
 303 the four SINC models presented in Figure 2. The determination of the approximate MRMT
 304 models is achieved with the numerical identification method in the temporal domain (Section
 305 4.1 and *Appendix C*).

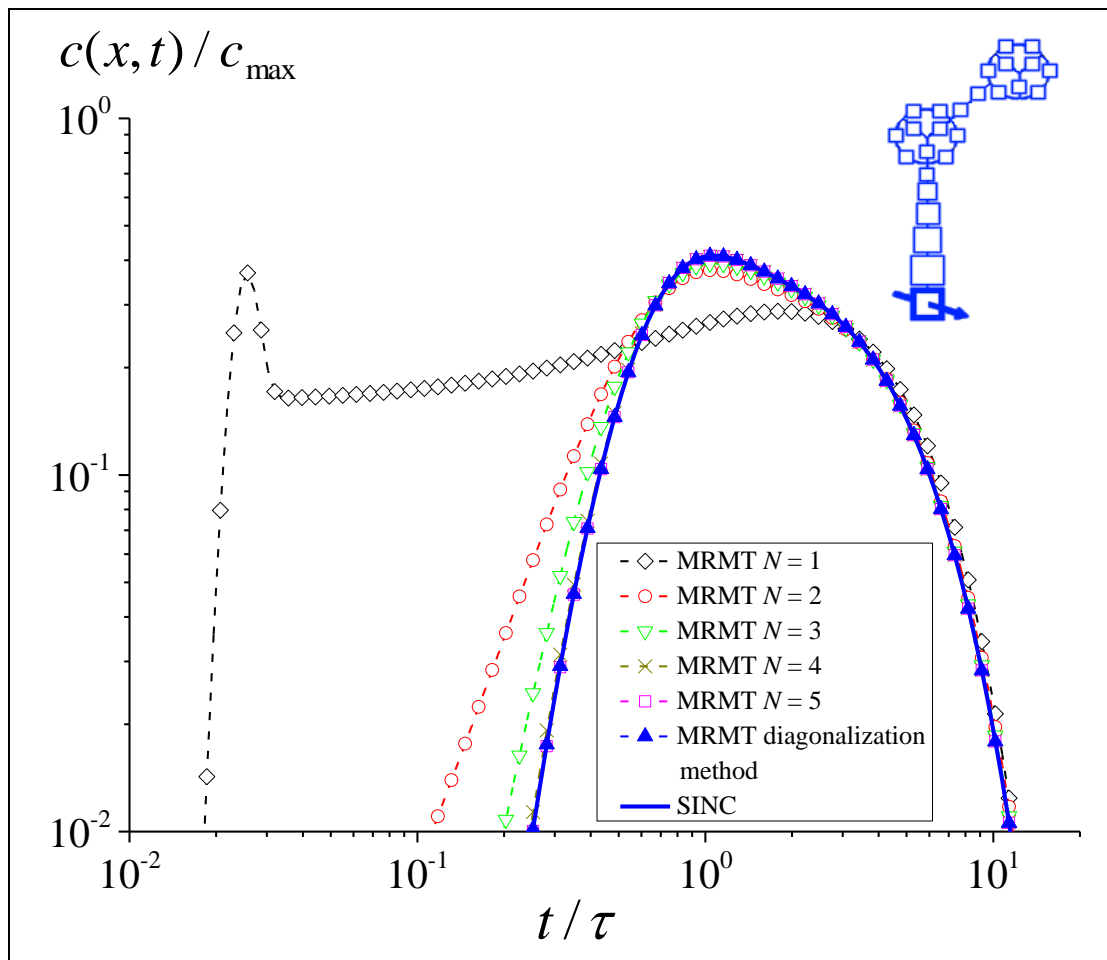

306 Figure 6: Breakthrough curves for the dissolution-like SINC model (Figure 2d) and for its
 307 equivalent MRMT models, either determined by the diagonalization method (section 3), or by
 308 the numerical method in the temporal domain with a limited number of N rates (Section 4.1
 309 and *Appendix C*). The concentrations are measured at the position $x = 20\sigma_0$.

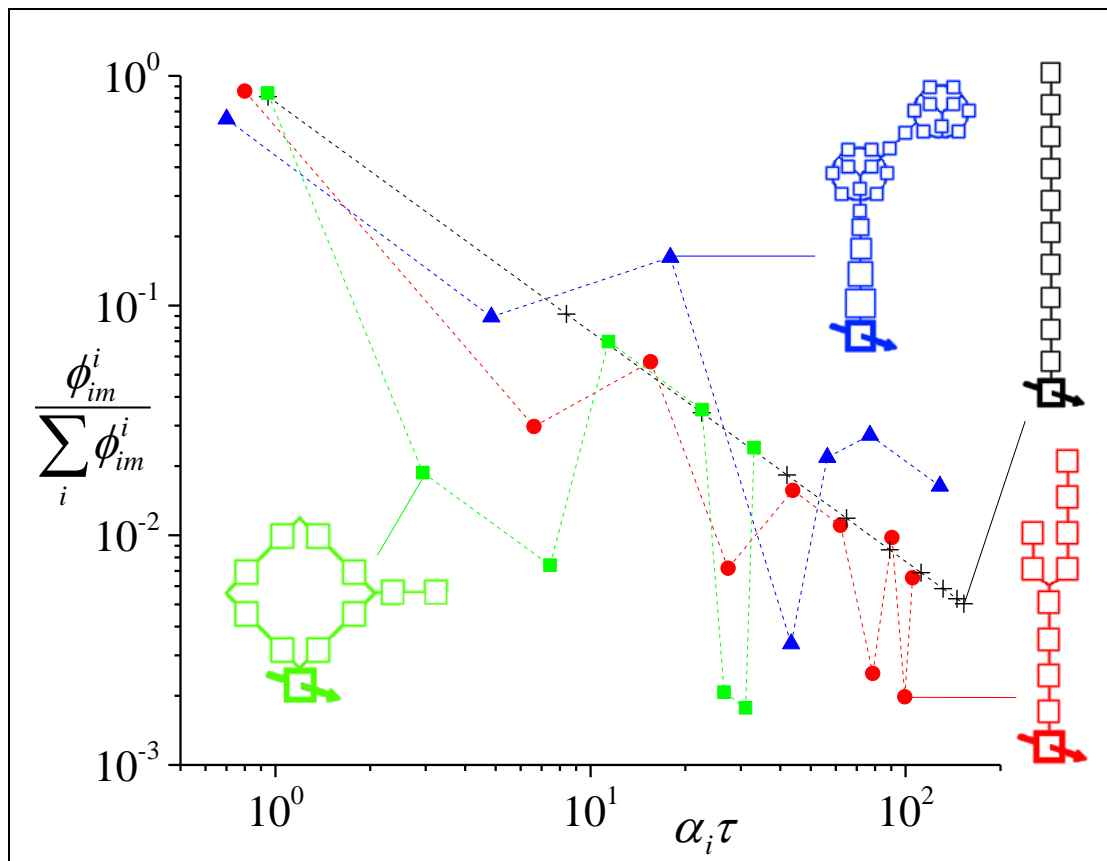

310 Figure 7: Normalized rates $\alpha_i \tau$ versus normalized porosities $\phi_{im}^i / \sum_i \phi_{im}^i$ for the MRMT
 311 models equivalent to the four diffusive porosity structures presented in Figure 2, as
 312 determined by the diagonalization method (section 3). Normalized rates larger than 200 or
 313 corresponding to a normalized porosity smaller than 10^{-3} have been truncated. .

314 **5 Conclusion**

315 We define a general mobile/immobile Structured INteracting Continua (SINC) transport
316 framework accounting for a broad variety of immobile porosity structures. Like in more
317 classical double porosity, Multi-Rate Mass Transfer (MRMT), and Multiple INteracting
318 Continua (MINC) frameworks, solute transport is dominated by advection in the mobile
319 porosity and is diffusion-like in the immobile porosity. The SINC framework introduces a
320 connectivity pattern within the immobile zone covering a broad range of diffusive geological
321 structures including cluster of dead-end fractures, irregular matrix shapes and dissolution
322 patterns. Immobile structures are based on branching and looping structures, and on any
323 combination of them. Solute transport is expressed as an advection-diffusion equation coupled
324 to algebraically defined exchanges with a finite number of immobile zones. Interactions
325 among the immobile zones and with the mobile zone are fully determined by a simple
326 interaction matrix, which resumes to an arrow type of matrix in the MRMT case and to a tri-
327 diagonal matrix in the MINC case. The graph of the matrix registers the connectivity pattern
328 while the value of its coefficients comes from relative porosities and strength of exchanges
329 between immobile zones.

330 We show that any Structured INteracting Continua model is equivalent to a unique MRMT
331 model, where the equivalence is defined as the strict identity of the concentrations in the
332 mobile zone, whatever the initial and boundary conditions. The rates of the equivalent MRMT
333 model are the eigenvalues of the subset of the interaction matrix where the line and column
334 corresponding to the mobile zone are removed. The diagonalization method gives a first
335 identification method of the equivalent MRMT with the same dimension, i.e. with the same
336 number of immobile zones. Because of limitations coming essentially from the dimension of
337 the immobile porosity structure, we set up alternative numerical methods designed to identify
338 the most important rates controlling the transport of solute. Developed both in the temporal
339 and Laplace domains, these methods seek for the combination of a finite number of
340 exponential functions that best matches a simple discharge of the immobile zones within a
341 quickly flushing mobile zone.

342 A simple sensitivity study on representative diffusive structures shows that very few rates are
343 needed for accurately modeling the solute transport in a 1D advection-dominated mobile zone
344 exchanging with an immobile porosity structure. Double porosity models (MRMT with a
345 single rate) already give the right order of magnitude of macrodispersion. Differences in

346 macrodispersion drop down to around 10% for two rates, to 1% for four rates, and to less than
347 0.1% for five rates. Simplified models based on only five rates approach accurately the
348 behavior of the system at intermediate to large times and only miss the very early responses.
349 While only few rates are necessary, their distribution and associated porosities are highly
350 variable, the complexity of the structure being transferred to the identified rates and
351 associated porosities. We thus conclude that MRMT models can be very efficient for
352 modeling diffusion-like transport in a broad range of porosity structures with only very few
353 rates. Even though numerical simulations have been done in 1D mobile domains, results are
354 likely generalize to 3D. Additional simulations should also be performed to investigate the
355 behavior of mixing and chemical reactivity both between different SINC structures and
356 between the SINC structures and their simplified MRMT counterparts.

357 **Appendix A: Diagonalization of \hat{A}**

358 We show that the eigenvalues of the matrix \hat{A} are real and negative and that they correspond
 359 to the opposites of the rates of the equivalent MRMT model ($-\alpha_i$). As displayed by
 360 equations (4) and (7), $\hat{A} = -\hat{\Phi}^{-1}\hat{M}$ where $\hat{\Phi} = \Phi(2\dots N+1, 2\dots N+1)$ and
 361 $\hat{M} = M(2\dots N+1, 2\dots N+1)$. $\hat{\Phi}^{-1}$ is diagonal and its diagonal elements are all positive.
 362 Thus $\hat{\Phi}^{-1}$ is positive definite, i.e. for every non-zero and real column vector x ,
 363 $x^T \hat{\Phi}^{-1} x = \sum_i \frac{x(i)^2}{\hat{\Phi}(i,i)} > 0$. \hat{M} is symmetrical, real, diagonally dominant $|\hat{M}(i,i)| \geq \sum_{j,j \neq i} |\hat{M}(i,j)|$,
 364 and strictly diagonally dominant $|\hat{M}(i,i)| > \sum_{j,j \neq i} |\hat{M}(i,j)|$ on its rows corresponding to the
 365 immobile zones connected to the mobile zone, due to the removal of the column
 366 corresponding to the mobile zone in the extraction of \hat{A} from A (equation (7)). If \hat{A} is
 367 additionally of rank N , then \hat{A} is diagonalizable, has real eigenvalues, and has the same
 368 number of positive and negative eigenvalues as $-\hat{M}$ [Horn, 1985].

369 We moreover show that $-\hat{M}$ and equivalently \hat{A} have strictly negative, real eigenvalues. It is
 370 the direct consequence [Horn, 1985] of $-\hat{M}$ being symmetrical, real, having only negative
 371 diagonal elements, and also being irreducible diagonally dominant. The diagonally dominance
 372 has been shown previously. The irreducibility property is more involved but can be proved by
 373 studying the properties of the graph defined by \hat{M} . When \hat{M} represents an immobile
 374 structure connected to the mobile structure by a single link, at least one path exists from any
 375 immobile cell to any other immobile cell that does not cross the mobile zone, then the graph
 376 defined by \hat{M} is strongly connected, so \hat{M} is irreducible [Horn, 1985]. When several
 377 immobile zones are independently connected to the mobile zone, each of these immobile
 378 zones is associated to a strongly connected graph and to an irreducible diagonally dominant
 379 matrix, itself a sub-matrix of \hat{M} . The eigenvalues and eigenvectors of \hat{M} are then obtained
 380 by clustering the ones of the sub-matrices.

381

382 **Appendix B: Construction of the matrix B**

383 The norm of each eigenvector in \widehat{R} is defined up to a constant. A first straightforward step is
 384 to adjust these norms so that the sum along the $2..N+1$ rows of B is equal to zero. It is
 385 achieved by taking $B_{i+1,1} = -\Lambda_i$, overly written in matrix form

$$\begin{bmatrix} B_{2,1} \\ \vdots \\ B_{N+1,1} \end{bmatrix} = -\Lambda \begin{bmatrix} 1 \\ \vdots \\ 1 \end{bmatrix}. \quad (\text{B1})$$

386 Given this choice and the properties of the matrices A and \widehat{R} , we demonstrate that the sum of
 387 the elements of the first line of B is also zero. We express the relation between the first
 388 columns of A and B from equation (12):

$$\begin{bmatrix} B_{2,1} \\ \vdots \\ B_{N+1,1} \end{bmatrix} = \widehat{R}^{-1} \begin{bmatrix} A_{2,1} \\ \vdots \\ A_{N+1,1} \end{bmatrix}. \quad (\text{B2})$$

389 As the sum of the elements of each line of A is zero

$$\begin{bmatrix} A_{2,1} \\ \vdots \\ A_{N+1,1} \end{bmatrix} = -\widehat{A} \begin{bmatrix} 1 \\ \vdots \\ 1 \end{bmatrix} \quad (\text{B3})$$

390 equation (B2) rewrites

$$\begin{bmatrix} B_{2,1} \\ \vdots \\ B_{N+1,1} \end{bmatrix} = -\widehat{R}^{-1} \widehat{A} \begin{bmatrix} 1 \\ \vdots \\ 1 \end{bmatrix} = -\Lambda \widehat{R}^{-1} \begin{bmatrix} 1 \\ \vdots \\ 1 \end{bmatrix}. \quad (\text{B4})$$

391 By substituting equation (B4) into equation (B1), we deduce that the eigenvectors comply
 392 with

$$\begin{bmatrix} 1 \\ \vdots \\ 1 \end{bmatrix} = \widehat{R} \begin{bmatrix} 1 \\ \vdots \\ 1 \end{bmatrix}. \quad (\text{B5})$$

393 As $R^{-1}U$ corresponds to the concentrations in the equivalent model (equation (13)), equation
 394 (B5) implies that a homogeneous immobile concentration profile in SINC remains unchanged
 395 in the equivalent model. We finally express the sum of the 2... $N+1$ elements of the first row of
 396 B and use the result of equation(B5):

$$\begin{aligned} \sum_{j=2}^{N+1} B_{1,j} &= \begin{bmatrix} B_{1,2} & \dots & B_{1,N+1} \end{bmatrix} \begin{bmatrix} 1 \\ \vdots \\ 1 \end{bmatrix} \\ &= \begin{bmatrix} A_{1,2} & \dots & A_{1,N+1} \end{bmatrix} \widehat{R} \begin{bmatrix} 1 \\ \vdots \\ 1 \end{bmatrix} \\ &= \begin{bmatrix} A_{1,2} & \dots & A_{1,N+1} \end{bmatrix} \begin{bmatrix} 1 \\ \vdots \\ 1 \end{bmatrix} = \sum_{j=2}^{N+1} A_{1,j} = -A_{1,1} \end{aligned} \quad (\text{B6})$$

397 An additional condition for B to be representative of a MRMT model is $B_{1,j} > 0$ for
 398 $j = 2 \dots N+1$. In the following we show that the adjustment of the norms of the eigenvectors is
 399 sufficient to ensure this condition. Equations (12) and (B2) give:

$$\begin{aligned}
 & \begin{bmatrix} B_{1,2} & \dots & B_{1,N+1} \end{bmatrix} \\
 &= \begin{bmatrix} A_{1,2} & \dots & A_{1,N+1} \end{bmatrix} \widehat{R} \\
 &= -\frac{1}{\phi_m} \begin{bmatrix} M_{1,2} & \dots & M_{1,N+1} \end{bmatrix} \widehat{R} \\
 &= -\frac{1}{\phi_m} \begin{bmatrix} M_{2,1} & \dots & M_{N+1,1} \end{bmatrix} \widehat{R} \quad \text{because } M \text{ is symmetric} \\
 &= -\frac{1}{\phi_m} \begin{bmatrix} \phi_{im}^1 A_{2,1} & \dots & \phi_{im}^N A_{N+1,1} \end{bmatrix} \widehat{R} \\
 &= -\frac{1}{\phi_m} \begin{bmatrix} A_{2,1} & \dots & A_{N+1,1} \end{bmatrix} \begin{bmatrix} \phi_{im}^1 & & \\ & \ddots & \\ & & \phi_{im}^N \end{bmatrix} \widehat{R} \\
 &= \frac{1}{\phi_m} \begin{bmatrix} B_{2,1} & \dots & B_{N+1,1} \end{bmatrix} \widehat{R}^T \begin{bmatrix} \phi_{im}^1 & & \\ & \ddots & \\ & & \phi_{im}^N \end{bmatrix} \widehat{R}
 \end{aligned} \tag{B7}$$

400 We now show that the matrix $\widehat{R}^T \widehat{\Phi} \widehat{R}$ with $\widehat{\Phi} = \Phi(2 \dots N+1, 2 \dots N+1)$ is diagonal with only
 401 positive diagonal elements.

402 We note $\widehat{A} = -\widehat{\Phi}^{-1} \widehat{M}$ with $\widehat{M} = M(2 \dots N+1, 2 \dots N+1)$. \widehat{M} is symmetric, its diagonal
 403 elements are positive, its non-zero off-diagonal elements are negative, but the sum of its
 404 elements over each of its rows is not equal to zero. As the ϕ_{im}^i are positive, we can consider
 405 the root of the matrix $\widehat{\Phi}$:

$$\widehat{A} = \widehat{\Phi}^{-1/2} \underbrace{(-1) \widehat{\Phi}^{-1/2} \widehat{M} \widehat{\Phi}^{-1/2}}_{\widehat{C}} \widehat{\Phi}^{1/2}. \tag{B8}$$

406 \widehat{C} is similar (in the mathematical sense) to \widehat{A} , so it is diagonalizable and has the same
 407 eigenvalues as \widehat{A} . Moreover \widehat{C} is symmetric, so it can be diagonalized by an orthogonal
 408 matrix S :

$$\widehat{C} = S \Lambda S^{-1} \tag{B9}$$

409 As a consequence, equation (B8) rewrites:

$$\begin{aligned}\widehat{A} &= \widehat{\Phi}^{-1/2} S \Lambda S^{-1} \widehat{\Phi}^{1/2} \\ &= \widehat{\Phi}^{-1/2} S \Lambda (\widehat{\Phi}^{-1/2} S)^{-1} .\end{aligned}\tag{B10}$$

410 As the norms of the eigenvectors in \widehat{R} are adjusted so the equation (B1) is verified, there
411 exists a unique orthogonal matrix S such that

$$S = \widehat{\Phi}^{1/2} \widehat{R} .\tag{B11}$$

412 As S is orthogonal, $S^T S$ is diagonal with only positive diagonal elements and writes

$$S^T S = (\widehat{\Phi}^{1/2} \widehat{R})^T \widehat{\Phi}^{1/2} \widehat{R} = \widehat{R}^T \widehat{\Phi}^{1/2} \widehat{\Phi}^{1/2} \widehat{R} = \widehat{R}^T \widehat{\Phi} \widehat{R} .\tag{B12}$$

413 The matrix $\widehat{R}^T \widehat{\Phi} \widehat{R}$, which is present in equation (B7), is thus diagonal with only positive
414 diagonal elements. Consequently, as the $B_{1,j}$ are positive for $j = 2 \dots N+1$, so are the $B_{j,1}$.

415

416 **Appendix C: Numerical identification method of MRMT models equivalent to a SINC**
 417 **model**

418 We set up an optimization scheme to get MRMT models equivalent to a SINC model. We
 419 first consider the case where the mass per unitary volume $m(t)$ discharged to an immobile
 420 zone from a flushing experiment can effectively be modeled by a series of N exponential
 421 functions with rates α_i and associate porosities ϕ_{im}^i ($m(t) = \gamma(t)$, see equation (15)). We
 422 derive a set of equivalent expressions in the Laplace domain with simple dependences on α_i
 423 and ϕ_{im}^i . We then deduce optimization strategies both in the Laplace and temporal domains.

424 We assume first that the SINC model is strictly equivalent to a given MRMT model as in
 425 section 2 ($m(t) = \gamma(t)$). It is the case when initial concentrations are homogeneous in the
 426 immobile zone and when the immobile zones are constantly discharging to a quickly flushed
 427 mobile zone where concentration is assumed to remain negligible ([Haggerty and Gorelick,
 428 1995], Appendix B). In the Laplace domain, exponential functions become simple rational
 429 functions and $\tilde{m}(p) = \tilde{\gamma}(p)$ is expressed as

$$\tilde{m}(p) = \sum_{i=1}^N \frac{\phi_{im}^i c_0}{\alpha_i} \frac{1}{1 + \frac{p}{\alpha_i}} \quad (C1)$$

430 where p is the Laplace variable and $\tilde{m}(p)$ (respectively $\tilde{\gamma}(p)$) is Laplace transform of $m(t)$
 431 (respectively $\gamma(t)$). We multiply equation (C1) by the polynomial $P(p)$ of degree N

$$P(p) = \prod_{i=1}^N \left(1 + \frac{p}{\alpha_i}\right) = 1 + a_1 p + a_2 p^2 + \dots + a_N p^N \quad (C2)$$

432 and obtain

$$(1 + a_1 p + a_2 p^2 + \dots + a_N p^N) \tilde{m}(p) = \sum_{i=1}^N \left[\frac{\phi_{im}^i c_0}{\alpha_i} \prod_{\substack{j=1 \\ j \neq i}}^N \left(1 + \frac{p}{\alpha_j}\right) \right]. \quad (C3)$$

433 If we now consider the polynomial $Q_i(p)$ of degree $N-1$

$$Q_i(p) = \prod_{\substack{j=1 \\ j \neq i}}^N \left(1 + \frac{p}{\alpha_j}\right) = 1 + a_{i,1}p + a_{i,2}p^2 + \dots + a_{i,N-1}p^{N-1} \quad (\text{C4})$$

434 and substitute equation (C4) into equation (C3), we obtain:

$$(a_1p + a_2p^2 + \dots + a_Np^N)\tilde{m}(p) + \tilde{m}(p) = \sum_{i=1}^N \frac{\phi_{im}^i c_0}{\alpha_i} (1 + a_{i,1}p + a_{i,2}p^2 + \dots + a_{i,N-1}p^{N-1}). \quad (\text{C5})$$

435 The interest of equation (C5) is to be linear in the a_i (polynomial coefficients of $P(p)$) and in
 436 ϕ_{im}^i / α_i with $i=1..N$. We isolate these quantities from the Laplace parameter-dependant
 437 elements to obtain the linear system

$$\varphi^T(p)\theta = y(p) \quad (\text{C6})$$

438 with

$$\varphi(p) = \begin{bmatrix} p\tilde{m}(p) \\ p^2\tilde{m}(p) \\ \vdots \\ p^N\tilde{m}(p) \\ -1 \\ -p \\ \vdots \\ -p^{N-1} \end{bmatrix}, \theta = \begin{bmatrix} a_1 \\ a_2 \\ \vdots \\ a_N \\ \sum_{i=1}^N \frac{\phi_{im}^i c_0}{\alpha_i} \\ \sum_{i=1}^N \frac{\phi_{im}^i c_0}{\alpha_i} a_{i,1} \\ \vdots \\ \sum_{i=1}^N \frac{\phi_{im}^i c_0}{\alpha_i} a_{i,N-1} \end{bmatrix}, y(p) = -\tilde{m}(p). \quad (\text{C7})$$

439 Both $\varphi(p)$ and θ are vectors of dimension $2N$. The rates $-\alpha_i$ are directly obtained from the
 440 roots of the polynomial $P(p)$ of equation (C2), whose coefficients are given by $\theta_1.. \theta_N$. The
 441 porosities ϕ_{im}^i are further deduced from $\theta_{N+1}.. \theta_{2N}$ by inverting the $N+1..2N$ equations of (C7):

$$\begin{bmatrix} \phi_{im}^1 \\ \phi_{im}^2 \\ \vdots \\ \phi_{im}^N \end{bmatrix} = G^{-1} \begin{bmatrix} \theta_{N+1} \\ \theta_{N+2} \\ \vdots \\ \theta_{2N} \end{bmatrix} \quad (\text{C8})$$

442 with

$$G = \begin{bmatrix} c_0/\alpha_1 & \cdots & c_0/\alpha_N \\ c_0 a_{1,1}/\alpha_1 & \cdots & c_0 a_{N,1}/\alpha_N \\ \vdots & & \vdots \\ c_0 a_{1,N-1}/\alpha_1 & \cdots & c_0 a_{N,N-1}/\alpha_N \end{bmatrix} \quad (\text{C9})$$

443 where the values of $a_{i,j}$ are deduced from the identified values of α_i . In the case of strict
 444 equivalence between MRMT and SINC models, the equivalent MRMT model can be found
 445 through (C6)-(C9).

446 In the case where MRMT and SINC models are not strictly equivalent, we seek for the
 447 composition of N exponential functions that best matches $\tilde{m}(p)$ on a given sampling of the
 448 Laplace parameter p_k , $k=1,\dots,K$ of p by using a least-square method, minimizing the
 449 mismatch objective function J [Garnier *et al.*, 2008; Ljung, 1999]:

$$J = \sum_{k=1}^K \left(y(p_k) - \varphi^T(p_k)\theta \right)^2. \quad (\text{C10})$$

450 The sampling should be extensive enough to contain all the information necessary to identify
 451 the different rates. If α_N is the largest rate, the initial time sampling should be smaller than
 452 $\alpha_N^{-1}/2$ following the spirit of Shannon's theorem. Adequate time sampling could then
 453 increase with time for determining the smaller rates.

454 The minimum $\tilde{\theta}$ of J is explicitly given by:

$$\tilde{\theta} = \left(\sum_{k=1}^K \varphi(p_k)\varphi^T(p_k) \right)^{-1} \sum_{k=1}^K \varphi(p_k)y(p_k) \quad (\text{C11})$$

455 and the α_i and ϕ_{im}^i coefficients can be determined from the approximate $\tilde{\theta}_i$ coefficients and
 456 (C6)-(C9).

457 $\tilde{\theta}$ can also be obtained in the temporal domain. We first divide equation (C5) by p^N (which is
 458 equivalent to integrate N times over t in the temporal domain) because of the better numerical
 459 stability of integration compared to derivation

$$\left(\frac{1}{p^N} + a_1 \frac{1}{p^{N-1}} + a_2 \frac{1}{p^{N-2}} + \dots + a_N\right) \tilde{m}(p) = \sum_{i=1}^N \frac{\phi_{im}^i c_0}{\alpha_i} \left(\frac{1}{p^N} + a_{i,1} \frac{1}{p^{N-1}} + a_{i,2} \frac{1}{p^{N-2}} + \dots + a_{i,N-1} \frac{1}{p}\right). \quad (\text{C12})$$

460 For convenience, we note

$$\int^{(n)} m(u) du = \int_0^t \int_0^{u_1} \int_0^{u_2} \dots \int_0^{u_{n-1}} m(u_n) du_n \dots du_2 du_1. \quad (\text{C13})$$

461 The inverse Laplace transform of equation (C12) gives

$$\begin{aligned} \int^{(N)} m(u) du + a_1 \int^{(N-1)} m(u) du + a_2 \int^{(N-2)} m(u) du + \dots + a_N m(t) = \\ \sum_{i=1}^N \frac{\phi_{im}^i c_0}{\alpha_i} \left(\frac{t^{N-1}}{(N-1)!} + a_{i,1} \frac{t^{N-2}}{(N-2)!} + a_{i,2} \frac{t^{N-3}}{(N-3)!} + \dots + a_{i,N-1} \right) \end{aligned} \quad (\text{C14})$$

462 As done previously in the Laplace domain, we separate the time-dependent elements from the
463 quantities depending on ϕ_{im}^i and α_i

$$\varphi(t) = \begin{bmatrix} \int^{(N-1)} m(u) du \\ \int^{(N-2)} m(u) du \\ \vdots \\ m(t) \\ -\frac{t^{N-1}}{(N-1)!} \\ -\frac{t^{N-2}}{(N-2)!} \\ \vdots \\ -1 \end{bmatrix}, \theta = \begin{bmatrix} a_1 \\ a_2 \\ \vdots \\ a_N \\ \sum_{i=1}^N \frac{\phi_{im}^i c_0}{\alpha_i} \\ \sum_{i=1}^N \frac{\phi_{im}^i c_0}{\alpha_i} a_{i,1} \\ \vdots \\ \sum_{i=1}^N \frac{\phi_{im}^i c_0}{\alpha_i} a_{i,N-1} \end{bmatrix}, y(t) = -\int^{(N)} m(u) du. \quad (\text{C15})$$

464 θ may also be obtained with a similar least-square method by considering a discretization of
465 time t_k ($k=1\dots K$) and by minimizing the objective function

$$J = \sum_{k=1}^K \left(y(t_k) - \varphi^T(t_k) \theta \right)^2. \quad (\text{C16})$$

466 The minimum $\tilde{\theta}$ is given by

$$\tilde{\theta} = \left(\sum_{k=1}^K \varphi(t_k) \varphi^T(t_k) \right)^{-1} \sum_{k=1}^K \varphi(t_k) y(t_k). \quad (\text{C17})$$

467 **Appendix D: Application of the numerical identification method to cases $N = 1$ and**
 468 $N = 2$

469 We recall the expression of the discharge of one immobile zone in MRMT model into a
 470 mobile zone of constant concentration zero (equation (C1)):

$$m(t) = \sum_{i=1}^N c_0 \phi_{im}^i \exp(-\alpha_i t) \quad (\text{D1})$$

471 where $m(t)$ is the remaining mass per unitary volume of solute and c_0 is the initial
 472 homogeneous immobile concentration.

473 **Case $N = 1$**

474 In Laplace domain, equation (D1) rewrites:

$$\tilde{m}(p) = \frac{\phi_{im}^1 c_0}{\alpha_1} \frac{1}{1 + \frac{p}{\alpha_1}} \quad (\text{D2})$$

$$\left(1 + \frac{p}{\alpha_1}\right) \tilde{m}(p) = \frac{\phi_{im}^1 c_0}{\alpha_1} \quad (\text{D3})$$

475 Dividing equation (D3) by p and then using the inverse Laplace transform, we obtain:

$$\int_0^t m(u) du + \frac{m(t)}{\alpha_1} = \frac{\phi_{im}^1 c_0}{\alpha_1} \quad (\text{D4})$$

476 Equations (D3) and (D4) are both linear in quantities depending on the unknown parameters
 477 α_1 and ϕ_{im}^1 to be identified. Equation (D4) can be written under the form:

$$\varphi^T(t) \theta = y(t) \quad (\text{D5})$$

478 with:

$$\varphi(t) = \begin{bmatrix} m(t) \\ -1 \end{bmatrix}, \quad \theta = \begin{bmatrix} 1/\alpha_1 \\ c_0 \phi_{im}^1 / \alpha_1 \end{bmatrix}, \quad y(t) = -\int_0^t m(u) du. \quad (\text{D6})$$

479 The vector $\tilde{\theta}$ which minimize the quantity:

$$J = \sum_{k=1}^K \left(y(t_k) - \varphi^T(t_k) \theta \right)^2 \quad (\text{D7})$$

480 with a discretization t_k , $k = 1, \dots, K$ of t , is given by:

$$\tilde{\theta} = \left(\sum_{k=1}^K \varphi(t_k) \varphi^T(t_k) \right)^{-1} \sum_{k=1}^K \varphi(t_k) y(t_k) \quad (\text{D8})$$

481 where

$$\varphi(t_k) \varphi^T(t_k) = \begin{bmatrix} m(t_k)^2 & -m(t_k) \\ -m(t_k) & 1 \end{bmatrix}, \quad \varphi(t_k) y(t_k) = \begin{bmatrix} -m(t_k) \int_0^{t_k} m(u) du \\ \int_0^{t_k} m(u) du \end{bmatrix} \quad (\text{D9})$$

482 so

$$\tilde{\theta} = \begin{bmatrix} \sum_{k=1}^K m(t_k)^2 & -\sum_{k=1}^K m(t_k) \\ -\sum_{k=1}^K m(t_k) & K \end{bmatrix}^{-1} \begin{bmatrix} -\sum_{k=1}^K m(t_k) \int_0^{t_k} m(u) du \\ \sum_{k=1}^K \int_0^{t_k} m(u) du \end{bmatrix}. \quad (\text{D10})$$

483 We then get α_1 and ϕ_{im}^1 :

$$\alpha_1 = \frac{1}{\tilde{\theta}_1}, \quad \phi_{im}^1 = \frac{\tilde{\theta}_2 \alpha_1}{c_0}. \quad (\text{D11})$$

484 **Case $N = 2$**

485 In Laplace domain, equation (D1) rewrites:

$$\tilde{m}(p) = \frac{\phi_{im}^1 c_0}{\alpha_1} \frac{1}{1 + \frac{p}{\alpha_1}} + \frac{\phi_{im}^2 c_0}{\alpha_2} \frac{1}{1 + \frac{p}{\alpha_2}} \quad (\text{D12})$$

486 which gives when multiplied by $(1 + p/\alpha_1)(1 + p/\alpha_2)$

$$(1 + p/\alpha_1)(1 + p/\alpha_2) \tilde{m}(p) = \frac{\phi_{im}^1 c_0}{\alpha_1} (1 + p/\alpha_2) + \frac{\phi_{im}^2 c_0}{\alpha_2} (1 + p/\alpha_1). \quad (\text{D13})$$

487 We divide then equation (D13) by p^2 (which is equivalent to integrate two times over t)

$$\frac{1}{\alpha_1 \alpha_2} \tilde{m}(p) + \left(\frac{1}{\alpha_1} + \frac{1}{\alpha_2} \right) \frac{\tilde{m}(p)}{p} + \frac{\tilde{m}(p)}{p^2} = \frac{\phi_{im}^1 c_0}{\alpha_1} \left(\frac{1}{p^2} + \frac{1}{p \alpha_2} \right) + \frac{\phi_{im}^2 c_0}{\alpha_2} \left(\frac{1}{p^2} + \frac{1}{p \alpha_1} \right). \quad (D14)$$

488 Then, by using the inverse Laplace transform, we obtain:

$$\frac{1}{\alpha_1 \alpha_2} m(t) + \left(\frac{1}{\alpha_1} + \frac{1}{\alpha_2} \right) \int_0^t m(u) du + \int_0^t \int_0^u m(v) dv du = \frac{\phi_{im}^1 c_0}{\alpha_1} \left(t + \frac{1}{\alpha_2} \right) + \frac{\phi_{im}^2 c_0}{\alpha_2} \left(t + \frac{1}{\alpha_1} \right). \quad (D15)$$

489 Again equations (D12) and (D13) are both linear in quantities depending on the unknown
 490 parameters α_i and ϕ_{im}^i to be identified. Equation (D15) and can be written under the form:

$$\varphi^T(t) \theta = y(t) \quad (D16)$$

491 with:

$$\varphi(t) = \begin{bmatrix} \int_0^t m(u) du \\ m(t) \\ -t \\ -1 \end{bmatrix}, \quad \theta = \begin{bmatrix} 1/\alpha_1 + 1/\alpha_2 \\ 1/(\alpha_1 \alpha_2) \\ \frac{\phi_{im}^1 c_0}{\alpha_1} + \frac{\phi_{im}^2 c_0}{\alpha_2} \\ \frac{\phi_{im}^1 c_0}{\alpha_1 \alpha_2} + \frac{\phi_{im}^2 c_0}{\alpha_1 \alpha_2} \end{bmatrix}, \quad y(t) = - \int_0^t \int_0^u m(v) dv du. \quad (D17)$$

492 The vector $\tilde{\theta}$ which minimizes the quantity:

$$J = \sum_{k=1}^K \left(y(t_k) - \varphi^T(t_k) \theta \right)^2 \quad (D18)$$

493 with a discretization t_k , $k = 1, \dots, K$ of t , is given by:

$$\tilde{\theta} = \left(\sum_{k=1}^K \varphi(t_k) \varphi^T(t_k) \right)^{-1} \sum_{k=1}^K \varphi(t_k) y(t_k). \quad (D19)$$

494 We then have the following relations:

$$\begin{cases} 1/\alpha_1 + 1/\alpha_2 & = \tilde{\theta}_1 \\ 1/(\alpha_1\alpha_2) & = \tilde{\theta}_2 \\ \frac{\phi_{im}^1 c_0}{\alpha_1} + \frac{\phi_{im}^2 c_0}{\alpha_2} & = \tilde{\theta}_3 \\ \frac{\phi_{im}^1 c_0}{\alpha_1\alpha_2} + \frac{\phi_{im}^2 c_0}{\alpha_1\alpha_2} & = \tilde{\theta}_4 \end{cases} \quad (\text{D20})$$

495 from which we can identify the unknown parameters $-\alpha_1$ and $-\alpha_2$ may be obtained as the
 496 roots of the polynomial $1 + \tilde{\theta}_1 x + \tilde{\theta}_2 x^2$. Once α_1 and α_2 are identified, ϕ_{im}^1 and ϕ_{im}^2 are given
 497 by:

$$\begin{bmatrix} \phi_{im}^1 \\ \phi_{im}^2 \end{bmatrix} = \frac{1}{c_0} \begin{bmatrix} 1/\alpha_1 & 1/\alpha_2 \\ 1/\alpha_1\alpha_2 & 1/\alpha_1\alpha_2 \end{bmatrix}^{-1} \begin{bmatrix} \tilde{\theta}_3 \\ \tilde{\theta}_4 \end{bmatrix}. \quad (\text{D21})$$

Acknowledgements

The ANR is acknowledged for its funding through its project H2MNO4 under the number ANR-12-MONU-0012-01. The authors are also grateful to Linda Luquot, Alain Rapaport and Jesús Carrera for stimulating discussions, and additionally to Linda Luquot for providing the illustrative dissolution patterns. We also thank the four anonymous reviewers for their insightful and critical review of the manuscript, as well as Cass Miller for his editorial work.

References

- Benson, D. A., and M. M. Meerschaert (2009), A simple and efficient random walk solution of multi-rate mobile/immobile mass transport equations, *Advances in Water Resources*, 32(4), 532-539, doi:http://dx.doi.org/10.1016/j.advwatres.2009.01.002.
- Benson, D. A., R. Schumer, M. M. Meerschaert, and S. W. Wheatcraft (2001), Fractional dispersion, Lévy motion, and the MADE tracer test, *Transport in Porous Media*, 42(1-2), 211-240, doi:10.1007/978-94-017-1278-1_11.
- Benson, D. A., S. W. Wheatcraft, and M. M. Meerschaert (2000), Application of a fractional advection-dispersion equation, *Water Resources Research*, 36(6), doi:http://dx.doi.org/10.1029/2000WR900031.
- Berkowitz, B., A. Cortis, M. Dentz, and H. Scher (2006), Modeling non-Fickian transport in geological formations as a continuous time random walk, *Reviews of Geophysics*, 44(2), doi:10.1029/2005rg000178.
- Berkowitz, B., and H. Scher (1998), Theory of anomalous chemical transport in random fracture networks, *Physical Review E*, 57(5), doi:http://dx.doi.org/10.1103/PhysRevE.57.5858.
- Berkowitz, B., H. Scher, and S. Silliman (2000), Anomalous transport in laboratory-scale, heterogeneous porous media, *Water Resources Research*, 36(1), doi:http://dx.doi.org/10.1029/1999WR900295.
- Carrera, J., X. Sánchez-Vila, I. Benet, A. Medina, G. Galarza, and J. Guimerà (1998), On matrix diffusion: formulations, solution methods and qualitative effects, *Hydrogeology Journal*, 6(1), doi:http://dx.doi.org/10.1007/s100400050143.
- Cushman, J. H., and T. R. Ginn (2000), Fractional advection-dispersion equation: A classical mass balance with convolution-Fickian flux, *Water Resources Research*, 36(12), doi:http://dx.doi.org/10.1029/2000WR900261.
- de Dreuzy, J. R., A. Rapaport, T. Babey, and J. Harmand (2013), Influence of porosity structures on mixing-induced reactivity at chemical equilibrium in mobile/immobile Multi-Rate Mass Transfer (MRMT) and Multiple INteracting Continua (MINC) models, *Water Resources Research*, 49(12), 8511-8530, doi:10.1002/2013WR013808.
- Dentz, M., and B. Berkowitz (2003), Transport behavior of a passive solute in continuous time random walks and multirate mass transfer, *Water Resources Research*, 39(5), 1111, doi:10.1029/2001WR001163.
- Dentz, M., A. Cortis, H. Scher, and B. Berkowitz (2004), Time behavior of solute transport in heterogeneous media: transition from anomalous to normal transport, *Advances in Water Resources*, 27(2), 155-173, doi:http://dx.doi.org/10.1016/j.advwatres.2003.11.002.
- Fernandez-Garcia, D., G. Llerar-Meza, and J. J. Gomez-Hernandez (2009), Upscaling transport with mass transfer models: Mean behavior and propagation of uncertainty, *Water Resources Research*, 45, doi:10.1029/2009wr007764.
- Flekkøy, E. G., A. Malthé-Sørensen, and B. Jamtveit (2002), Modeling hydrofracture, *J. Geophys. Res.*, 107(B8), 2151.
- Garnier, H., L. Wang, and P. Young (2008), Direct Identification of Continuous-time Models from Sampled Data: Issues, Basic Solutions and Relevance, in *Identification of Continuous-time Models from Sampled Data*, edited by H. Garnier and L. Wang, pp. 1-29, Springer London, doi:10.1007/978-1-84800-161-9_1.

- Golfier, F., M. Quintard, F. Cherblanc, B. A. Zinn, and B. D. Wood (2007), Comparison of theory and experiment for solute transport in highly heterogeneous porous medium, *Advances in Water Resources*, 30(11), 2235-2261, doi:10.1016/j.advwatres.2007.05.004.
- Golfier, F., C. Zarcone, B. Bazin, R. Lenormand, D. Lasseux, and M. Quintard (2002), On the ability of a Darcy-scale model to capture wormhole formation during the dissolution of a porous medium, *Journal of Fluid Mechanics*, 457, 213-254, doi:10.1017/s0022112002007735.
- Gotovac, H., V. Cvetkovic, and R. Andricevic (2009), Flow and travel time statistics in highly heterogeneous porous media, *Water Resources Research*, 45, 24, doi:http://dx.doi.org/10.1029/2008WR007168.
- Gouze, P., Y. Melean, T. Le Borgne, M. Dentz, and J. Carrera (2008), Non-Fickian dispersion in porous media explained by heterogeneous microscale matrix diffusion, *Water Resources Research*, 44(11), 19, doi:http://dx.doi.org/10.1029/2007wr006690.
- Haggerty, R. (2001), Matrix diffusion - heavy-tailed residence time distributions and their influence on radionuclide retention, paper presented at 5th GEOTRAP Workshop on Radionuclide Retention in Geologic Media, May 7-9, 2001, Organisation for Economic Co-Operation and Development, Nuclear Energy Agency, 75 - Paris (France), Oskarshamn, Sweden, 2002.
- Haggerty, R., S. W. Fleming, L. C. Meigs, and S. A. McKenna (2001), Tracer tests in a fractured dolomite 2. Analysis of mass transfer in single-well injection-withdrawal tests, *Water Resources Research*, 37(5), doi:http://dx.doi.org/10.1029/2000WR900334.
- Haggerty, R., and S. M. Gorelick (1995), Multiple-Rate Mass Transfer for Modeling Diffusion and Surface Reactions in Media with Pore-Scale Heterogeneity, *Water Resources Research*, 31(10), 2383-2400, doi:10.1029/95WR10583.
- Haggerty, R., C. F. Harvey, C. F. von Schwerin, and L. C. Meigs (2004), What controls the apparent timescale of solute mass transfer in aquifers and soils? A comparison of experimental results, *Water Resources Research*, 40(1), doi:10.1029/2002wr001716.
- Haggerty, R., S. A. McKenna, and L. C. Meigs (2000), On the late-time behavior of tracer test breakthrough curves, *Water Resources Research*, 36(12), 3467-3479, doi:http://dx.doi.org/10.1029/2000WR900214.
- Horn, R. A. (1985), *Matrix analysis / Roger A. Horn, Charles R. Johnson*, Cambridge University Press, Cambridge ; New York.
- Jardine, P. M., W. E. Sanford, J. P. Gwo, O. C. Reedy, D. S. Hicks, J. S. Riggs, and W. B. Bailey (1999), Quantifying diffusive mass transfer in fractured shale bedrock, *Water Resources Research*, 35(7), 2015-2030, doi:10.1029/1999WR900043.
- Karimi-Fard, M., B. Gong, and L. J. Durlofsky (2006), Generation of coarse-scale continuum flow models from detailed fracture characterizations, *Water Resources Research*, 42(10), doi:http://dx.doi.org/10.1029/2006WR005015.
- Ljung, L. (1999), *System identification : theory for the user*, Prentice Hall, Upper Saddle River.
- Luquot, L., O. Rodriguez, and P. Gouze (2014), Experimental Characterization of Porosity Structure and Transport Property Changes in Limestone Undergoing Different Dissolution Regimes, *Transp Porous Med*, 101(3), 507-532, doi:10.1007/s11242-013-0257-4.
- Michalak, A. M., and P. K. Kitanidis (2000), Macroscopic behavior and random-walk particle tracking of kinetically sorbing solutes, *Water Resources Research*, 36(8), 2133-2146, doi:10.1029/2000wr900109.

- Neretnieks, I. (1980), Diffusion in the Rock Matrix: An Important Factor in Radionuclide Retardation?, *Journal of Geophysical Research*, 85(B8), 4379-4397, doi:<http://dx.doi.org/10.1029/JB085iB08p04379>.
- Neuman, S. P., and D. M. Tartakovsky (2009), Perspective on theories of non-Fickian transport in heterogeneous media, *Advances in Water Resources*, 32(5), 670-680, doi:10.1016/j.advwatres.2008.08.005.
- Noetinger, B., and T. Estebenet (2000), Up-scaling of double porosity fractured media using continuous-time random walks methods, *Transport in Porous Media*, 39(3).
- Pruess, K. (1992), Brief Guide to the MINC - Method for Modeling Flow and Transport in Fractured Media Rep., Earth Sciences Division, Lawrence Berkeley National Laboratory. Berkeley CA USA.
- Pruess, K., and T. N. Narasimhan (1985), A practical method for modeling fluid and heat-flow in fractured porous-media, *Society of Petroleum Engineers Journal*, 25(1), 14-26, doi:<http://dx.doi.org/10.2118/10509-PA>.
- Silva, O., J. Carrera, M. Dentz, S. Kumar, A. Alcolea, and M. Willmann (2009), A general real-time formulation for multi-rate mass transfer problems, *Hydrology and Earth System Sciences*, 13(8), 1399-1411, doi:<http://dx.doi.org/10.5194/hess-13-1399-2009>.
- Sornette, A., P. Davy, and D. Sornette (1993), Fault Growth in Brittle-Ductile Experiments and the Mechanics of Continental Collisions, *Journal of Geophysical Research-Solid Earth*, 98(B7), 12111-12139, doi:<http://dx.doi.org/10.1029/92JB01740>.
- Sudicky, E. A., and E. O. Frind (1982), Contaminant transport in fractured porous-media - analytical solutions for a system of parallel fractures, *Water Resources Research*, 18(6), 1634-1642, doi:<http://dx.doi.org/10.1029/WR018i006p01634>.
- Tang, D. H., E. O. Frind, and E. A. Sudicky (1981), Contaminant transport in fractured porous-media - analytical solution for a single fracture, *Water Resources Research*, 17(3), 555-564, doi:<http://dx.doi.org/10.1029/WR017i003p00555>.
- Tsang, Y. W. (1995), Study of alternative tracer tests in characterizing transport in fractured rocks, *Geophysical Research Letters*, 22(11), 1421-1424, doi:10.1029/95GL01093.
- Villiermaux, J. (1987), Chemical-engineering approach to dynamic modeling of linear chromatography - a flexible method for representing complex phenomena from simple concepts, *Journal of Chromatography*, 406, 11-26, doi:10.1016/s0021-9673(00)94014-7.
- Warren, J. E., P. J. Root, and M. Aime (1963), The Behavior of Naturally Fractured Reservoirs, *Society of Petroleum Engineers Journal*, September, 245-255, doi:<http://dx.doi.org/10.2118/426-PA>.
- Willmann, M., J. Carrera, and X. Sanchez-Vila (2008), Transport upscaling in heterogeneous aquifers: What physical parameters control memory functions?, *Water Resources Research*, 44(12), doi:10.1029/2007wr006531.

Figure captions

Figure 1: (a) Skeleton of a dissolution feature in an oolitic limestone, observed by X-ray micro-tomography [Luquot *et al.*, 2014]. The dissolving acidic solution percolates from top to bottom on the general view (bottom left). Its pH increases from top to bottom and from inside out of the main flow path indicated by the curved arrow on the detailed view (top right). The acid dissolves preferentially the calcite cement surrounding the oolites, the size of the pores progressively decreases away from the main flow path, and the organization of the pores becomes more complex. (b) Structured INteracting Continua model (SINC) sketched from the dissolution pattern of (a) with three cross sections transversal to the mobile zone materialized by the arrow. (c) Equivalent MRMT model with the 5 most important rates as determined by the numerical methods set up in section 4. The size of the boxes scales with the porosity affected to the rates labeled by triangles in Figure 7.

Figure 2: Examples of Structured INteracting Continua (SINC) used to illustrate and validate the numerical identification methods of the equivalent MRMT models. From left to right, the diffusive porosity structures are (a) the classical Multiple INteracting Continua (MINC) [Pruess and Narasimhan, 1985], (b) an asymmetric Y with a single junction, (c) an asymmetric loop, and (d) the dissolution structure presented in Figure 1. The size of the immobile cells is proportional to their porosity and the distance along the immobile structure is to scale. The mobile zone is represented by the thick black box with the crossing arrow. Its size has been exaggerated 10 times to be clearly marked. To be comparable, the four structures have the same total porous volume and the same radius of gyration taken with respect to the mobile zone.

Figure 3: Diffusive porosity structures represented as cross-sections transversal to the mobile zone direction ((a),(b)), with their associated interaction matrix A ((c),(d)) for the asymmetric Y (*top*) and MRMT structures (*bottom*). Dotted frames around subsets of the immobile porosity structures ((a) and (b)) and around matrix lines ((c) and (d)) show how structures are translated in matrix form. Parameters for the asymmetric Y structure are taken from Table 1 and the multiplicative factor η ($\eta=5.015$) is equal to the ratio of the distance between two consecutive immobile zones to the radius of gyration of the immobile domain to the mobile zone. β is the ratio of the total immobile porosity to the mobile porosity.

Figure 4: Diffusive porosity structures used to check the numerical implementation of the SINC model, equivalent to the "MINC 1D" structure (*left column*). These structures display the same behavior for homogeneous initial concentrations in the immobile zones. The mobile zone is the bold box with the arrow. The size of the boxes is proportional to the porosity of the compartments. Only the vertical distance of an immobile zone to the mobile zone is to scale.

Figure 5: Differences in macrodispersions $diff(D_{SINC}, D_{MRMT})$ (equation (20)) between SINC models and their approximate MRMT models with a limited number of rates $N=1$ to 5, for the four SINC models presented in Figure 2. The determination of the approximate MRMT models is achieved with the numerical identification method in the temporal domain (Section 4.1 and *Appendix C*).

Figure 6: Breakthrough curves for the dissolution-like SINC model (Figure 2d) and for its equivalent MRMT models, either determined by the diagonalization method (section 3), or by the numerical method in the temporal domain with a limited number of N rates (Section 4.1 and *Appendix C*). The concentrations are measured at the position $x = 20\sigma_0$.

Figure 7: Normalized rates $\alpha_i\tau$ versus normalized porosities $\phi_{im}^i / \sum_i \phi_{im}^i$ for the MRMT models equivalent to the four diffusive porosity structures presented in Figure 2, as determined by the diagonalization method (section 3). Normalized rates larger than 200 or corresponding to a normalized porosity smaller than 10^{-3} have been truncated. .