



HAL
open science

Identification of dynamic nonlinear thermal transfers for precise correction of bias induced by temperature variations

Céline Casenave, Gérard Montseny, Henri Camon, François Blard

► **To cite this version:**

Céline Casenave, Gérard Montseny, Henri Camon, François Blard. Identification of dynamic nonlinear thermal transfers for precise correction of bias induced by temperature variations. Symposium on Design, Test, Integration & Packagin of MEMS/MOEMS (DTIP 2010), May 2010, Seville, Spain. pp.376-381. hal-01061525

HAL Id: hal-01061525

<https://inria.hal.science/hal-01061525>

Submitted on 7 Sep 2014

HAL is a multi-disciplinary open access archive for the deposit and dissemination of scientific research documents, whether they are published or not. The documents may come from teaching and research institutions in France or abroad, or from public or private research centers.

L'archive ouverte pluridisciplinaire **HAL**, est destinée au dépôt et à la diffusion de documents scientifiques de niveau recherche, publiés ou non, émanant des établissements d'enseignement et de recherche français ou étrangers, des laboratoires publics ou privés.

Identification of Dynamic Nonlinear Thermal Transfers for Precise Correction of Bias induced by Temperature Variations

Céline Casenave*[†], Gérard Montseny*[†], Henri Camon*[†] and François Blard*[†]

*CNRS; LAAS; 7 avenue du colonel Roche, F-31077 Toulouse, France

[†]Université de Toulouse; UPS, INSA, INP, ISAE; LAAS; F-31077 Toulouse, France

Email: casenave@laas.fr, montseny@laas.fr, camon@laas.fr, francois.blard@laas.fr

Abstract—We present a least squares method for dynamic correction of biases induced by temperature variations when very high precision is required. This method is based on a simple dynamic model allowing to take into account the macroscopic effects of complex underlying thermal phenomena inside the device.

I. INTRODUCTION

In general, high precision devices, such as MEMS devoted to metrology applications for example, need to include algorithms allowing to correct biases resulting from variations of the ambient temperature. Most of time, static corrections are involved, which means that the ambient temperature (measured by means of a sensor) is supposed to be also the temperature at any point of the device itself.

This is of course not exactly true because the ambient temperature is never strictly constant and so, due to the complex distributed nature of physical objects, the temperature inside the device evolves following a complex diffusion equation. So, when measuring any physical quantity (for example a voltage) on the device under consideration, small residual fluctuations due to temperature variations remain in spite of the static correction, because *dynamic* thermal phenomena are involved, which cannot be described by means of a static correspondence.

In some cases, when *very high precision* is required, it can be judicious to envisage to build some *dynamic* corrections, elaborated from a suitable dynamic treatment of the temperature data, in such a way that the macroscopic effects resulting from the distributed evolution of the temperature inside the device can be taken into account, and then corrected.

In this paper, we present a method devoted to such a dynamic correction.

II. RECALLS ON STANDARD (STATIC) POLYNOMIAL CORRECTION

Consider a quantity U (to be measured), linked to the ambient temperature T through a *static* relation of the form:

$$U = f(T). \quad (1)$$

The aim is to correct the effect of the temperature T , that is to get an (if possible optimal) estimation of the quantity

$U_0 = f(T_0)$, where T_0 is chosen *a priori* as the reference temperature. If f is regular (which is the case in concrete situations), U can be expressed following the Taylor development around T_0 :

$$U = f(T_0) + f'(T_0)(T - T_0) + \frac{1}{2}f''(T_0)(T - T_0)^2 + \dots, \quad (2)$$

that is, if we consider that terms beyond the n^{th} order are negligible:

$$U = U_0 + \sum_{i=1}^n a_i(T - T_0)^i. \quad (3)$$

So if the coefficients a_i have been previously accurately estimated (from experimental measurements) and T is known, the bias induced by *sufficiently slow* temperature variations around T_0 can be corrected thanks to the relation:

$$U_0 = U - \sum_{i=1}^n a_i(T - T_0)^i. \quad (4)$$

Indeed, when U is measured N times with some additive *zero mean* noise w , we then have $\tilde{U}_k = U_k + w_k$, $k = 1 : N$ and so, we get the correction relation:

$$\begin{aligned} \tilde{U}_{0,k} &= \tilde{U}_k - \sum_{i=1}^n a_i(T_k - T_0)^i \\ &= U_k - \sum_{i=1}^n a_i(T_k - T_0)^i + w_k \\ &= U_0 + w_k, \quad k = 1 : N. \end{aligned} \quad (5)$$

An estimate of the unknown quantity U_0 can then be obtained by filtering the data \tilde{U}_{0k} , for example by:

$$\hat{U}_0 = \frac{1}{N} \sum_{k=1}^N \left(\tilde{U}_k - \sum_{i=1}^n a_i(T_k - T_0)^i \right). \quad (6)$$

We then have from (5) and thanks to the law of large numbers:

$$\mathbb{E}(\hat{U}_0) = U_0, \quad (7)$$

$$\hat{U}_0 = \frac{1}{N} \sum_{k=1}^N (U_0 + w_k) \rightarrow U_0 \text{ when } N \rightarrow \infty; \quad (8)$$

so, the estimate \hat{U}_0 is convergent and *unbiased*: the effects of temperature variations have been corrected. Finally, if the

unknown quantity U_0 is not exactly constant but presents some very slow (and small) variations, it can be pursued for example by means of the following *moving average* estimate based on the corrected data $\tilde{U}_{0,k}$:

$$\tilde{U}_{0,k} = \frac{1}{N} \sum_{q=0}^{N-1} \left[\tilde{U}_{k-q} - \sum_{i=1}^n a_i (T_{k-q} - T_0)^i \right], \quad (9)$$

with the following residual estimation noise (inherited from the measurement noise):

$$\varepsilon_k = \frac{1}{N} \sum_{q=0}^{N-1} w_{k-q}. \quad (10)$$

Preliminary estimation of the correction coefficients from experimental data The correction coefficients a_i are estimated from experimental data, whose number must be sufficiently large to make the residual estimation error negligible. In practice, this step can be very long, particularly if measurement data are significantly corrupted by noise. The classical estimation of coefficients a_i from data \tilde{U}_k , $k = 1 : K$ is in general obtained from the least squares method, that is by solving the problem:

$$\min_{a_i \in \mathbb{R}} \sum_{k=1}^K \left(\tilde{U}_k - a_0 - \sum_{i=1}^n a_i (T_k - T_0)^i \right)^2; \quad (11)$$

this problem is rewritten under the matrix form:

$$\min_{a \in \mathbb{R}^{n+1}} (Qa - \tilde{U})^T (Qa - \tilde{U}) \quad (12)$$

and the optimal solution $a^* = (a_i^*)$ is classically given by:

$$a^* = (Q^T Q + \varepsilon I)^{-1} Q^T \tilde{U} \quad (13)$$

with $\varepsilon \geq 0$ a small parameter devoted to numerical conditioning of the matrix inversion.

III. PRECISE CORRECTION OF BIAS FROM IDENTIFIED DYNAMIC THERMAL TRANSFER

A. Dynamic influence of the ambient temperature on a physical quantity

In practice, a physical system such as a MEMS with its environment is a *distributed* system: when the ambient temperature T is not constant, the temperature of the system cannot be a simple scalar: it becomes a *scalar field* $\theta(t, x)$, where each (vector) value of the spatial variable x is associated with a particular physical point of the system. If the variations of T remain small, the evolution of the field θ is theoretically governed by a complex but linear partial differential equation with input $T(t)$, of the abstract form:

$$\frac{\partial \theta(t, x)}{\partial t} = A(\nabla) \theta(t, x) + B(x) T(t), \quad x \in \Omega \subset \mathbb{R}^3, \quad (14)$$

where $A(\nabla)$ is a second order linear differential operator, associated with suitable boundary conditions, and B is the input operator describing how the exterior temperature T acts on the evolution of θ . Because equation (14) is in general

defined on $t > t_0$, the initial condition must be added in order to get a well-posed problem:

$$\theta(t_0, x) = \theta_0(x), \quad x \in \Omega. \quad (15)$$

Except in some ideal simple cases, such an equation is in practice impossible to formulate explicitly, due to the complexity of any physical system.

Similarly, a quantity U relating to the physical system under consideration and depending at first sight on T only, depends in general on the whole field θ . As in the ideal static cases, this dependence can of course be nonlinear, in such a way that we have formally:

$$U(t) = \mathbf{F}(\theta(t, x)), \quad (16)$$

where \mathbf{F} is a nonlinear spatial operator. So, the quantity U appears as an output of (14) and the dynamic (nonlinear) transfer $T \mapsto U$ is then resulting from the input-output correspondence defined by (14,16).

In most of cases, the evolution of $T(t)$ is slow and it can be considered that the difference $|\theta(t, x) - T(t)|$ can be neglected and then, the static approach previously described can be used. In some cases however, namely when very high precision is required, small differences between $\theta(t, x)$ and $T(t)$, which result from the *dynamic nature* of equation (14), can generate some significant residual biases which cannot be suppressed by *static* correction. In such cases, the static model (3) is no more sufficiently accurate and a *dynamic correction* is needed.

B. Dynamic correction of bias resulting from temperature variations

This correction method is based on an explicit and universal differential model of the dynamic transfer (14,16), as described here-after¹. First, thanks to the linear and diffusive nature of equation (14), a generic 1D diffusive input-state equation is used to model the underlying thermal dynamics. By assuming for simplicity that the mean ambient temperature is $T_0 = 0$, this model is:

$$\begin{cases} \frac{\partial \psi(t, \xi)}{\partial t} = -\xi \psi(t, \xi) + T(t), & \xi > 0, \quad t > t_0 \\ \psi(t_0, \xi) = 0. \end{cases} \quad (17)$$

On the other hand, from linearity, the contribution of the initial condition θ_0 is separately expressed from the exponential family:

$$\psi_0(t, \xi) = e^{-\xi t} \psi_0(\xi); \quad (18)$$

note that the function $(t, \xi) \mapsto \psi(t, \xi) + \psi_0(t, \xi)$ is solution of (17) with initial condition $\psi_0(\xi)$ in place of 0. We then define the function:

$$\Psi(t, \xi) := \psi(t, \xi) + \psi_0(t, \xi) - T(t) \quad (19)$$

¹This approach is relating to the so-called *diffusive representation*. More details about this theory and its applications in identification of nonlinear complex models or other various fields can be found in [3], [10].

which expresses the difference between the ambient "static" temperature and the dynamic field $\psi(t, \xi) + \psi_0(t, \xi)$; this function will be devoted to dynamic correction.

From ψ (the solution of (17)) and ψ_0 , we can then model the unknown dynamic transfer $T \mapsto U$ under the form $U = G(T, \Psi)$ with G a suitable nonlinear operator; a generic formulation of G is the following:

$$\begin{aligned} U(t) &= U_0 + \sum_i a_i T(t)^i + \int \mu_1(\xi) \Psi(t, \xi) d\xi \\ &+ \iint \mu_2(\xi_1, \xi_2) \Psi(t, \xi_1) \Psi(t, \xi_2) d\xi_1 d\xi_2 \\ &+ \iiint \mu_3(\xi_1, \xi_2, \xi_3) \Psi(t, \xi_1) \Psi(t, \xi_2) \Psi(t, \xi_3) d\xi_1 d\xi_2 d\xi_3 \\ &+ \iiiii \dots, \end{aligned} \quad (20)$$

where the coefficient a_i and the functions μ_i allow to synthesize from $T(t)$ and the field $\Psi(t, \xi)$ a wide class of nonlinear transfers. Thanks to the nice properties of equation (17), an approximated synthesis with only a few $\Psi_j(t) := \Psi(t, \xi_j)$, $\xi_j > 0$, of the form:

$$\begin{aligned} U(t) &= U_0 + \sum_{i=1}^n a_i T(t)^i + \sum_{j=1}^{J_1} \mu_{1,j} \Psi_j(t) \\ &+ \sum_{j=1}^{J_2} \sum_{j'=1}^{J_2'} \mu_{2,j,j'} \Psi_j(t) \Psi_{j'}(t) \\ &+ \sum_{j=1}^{J_3} \sum_{j'=1}^{J_3'} \sum_{j''=1}^{J_3''} \mu_{3,j,j',j''} \Psi_j(t) \Psi_{j'}(t) \Psi_{j''}(t) \\ &+ \sum_j \sum_{j'} \sum_{j''} \sum_{j'''} \dots, \end{aligned} \quad (21)$$

will be in practice sufficient to get accurate approximations of the dynamic nonlinear transfer $T \mapsto U$.

Finally, if the temperature variations are sufficiently small (this will be the case in the problem studied in the next section), the cross terms $\Psi_j \Psi_{j'}$, $\Psi_j \Psi_{j'} \Psi_{j''}$, etc., can be neglected and the following simplified synthesis will be yet sufficient to get significant improvement compared to the static model (3):

$$U(t) = U_0 + \sum_{i=1}^n a_i T(t)^i + \sum_{j=1}^J \mu_j (\psi_j(t) + \psi_{0,j}(t) - T(t)), \quad (22)$$

in such a way that (22) can be rewritten, from (18) and with $\nu_j := \mu_j \psi_0(\xi_j)$, under the following form in which all the correction parameters a_i, μ_j, ν_j are *linearly* involved:

$$U(t) = U_0 + \sum_{i=1}^n a_i T(t)^i + \sum_{j=1}^J \mu_j (\psi_j(t) - T(t)) + \sum_{j=1}^J \nu_j e^{-\xi_j t}. \quad (23)$$

Algorithm for dynamic correction Similarly to the static case, when U is measured at times $t_k = k\Delta t$ with some additive zero mean noise w_k that is $\tilde{U}_k = U_k + w_k$, and thanks

to the fact that $e^{-\xi_j t_k} \rightarrow 0$ when $k \rightarrow +\infty$, we finally get the asymptotic dynamic correction formula, suitable for large k (NB: the correction coefficients are a_i, μ_j):

$$\tilde{U}_{0,k} = \tilde{U}_k - \sum_{i=1}^n a_i (T_k)^i - \sum_{j=1}^J \mu_j (\psi_{j,k} - T_k), \quad (24)$$

where the quantities $\psi_{j,k}$, on which is based the dynamic correction, are computed from the temperature data T_k via the following discrete-time dynamic relation deduced from integration of (17):

$$\psi_{j,k+1} = e^{-\xi_j \Delta t} \psi_{j,k} + \frac{1 - e^{-\xi_j \Delta t}}{\xi_j} T_k. \quad (25)$$

Finally, exactly as in the static case, $\tilde{U}_{0,k} = U_0 + w_k$ and so, estimates \hat{U}_0 or $\bar{U}_{0,k}$ of the quantity U_0 can yet be taken as:

$$\hat{U}_0 = \frac{1}{N} \sum_{k=1}^N \tilde{U}_{0,k}, \quad \bar{U}_{0,k} = \frac{1}{N} \sum_{q=0}^{N-1} \tilde{U}_{0,k-q}; \quad (26)$$

we have yet, from (24) and thanks to the law of large numbers:

$$\mathbb{E}(\hat{U}_0) = U_0, \quad (27)$$

$$\hat{U}_0 = \frac{1}{N} \sum_{k=1}^N (U_0 + w_k) \rightarrow U_0 \text{ when } N \rightarrow \infty, \quad (28)$$

$$\varepsilon_k = \frac{1}{N} \sum_{q=0}^{N-1} w_{k-q}. \quad (29)$$

Preliminary estimation of the correction coefficients from experimental data The correction coefficients a_i, μ_j, ν_j are estimated from experimental data whose number must be sufficiently great to get negligible estimation errors. This estimation from data (with noise) \tilde{U}_k , $k = 1 : K$ is obtained again by means of the least squares method, by minimizing with respect to $a_i, \mu_j, \nu_j \in \mathbb{R}$ the quantity:

$$\begin{aligned} \mathcal{J} &= \sum_{k=1}^K \left(\tilde{U}_k - a_0 - \sum_{i=1}^n a_i (T_k)^i \right. \\ &\quad \left. - \sum_{j=1}^J \mu_j (\psi_{j,k} - T_k) - \sum_{j=1}^J \nu_j e^{-\xi_j t_k} \right)^2, \end{aligned} \quad (30)$$

which can be rewritten under matrix form, with $(a, \mu, \nu) \in \mathbb{R}^{(n+1)} \times \mathbb{R}^J \times \mathbb{R}^J$:

$$\min_{(a, \mu, \nu)} \left[\mathbf{Q} \begin{pmatrix} a \\ \mu \\ \nu \end{pmatrix} - \tilde{\mathbf{U}} \right]^T \cdot \left[\mathbf{Q} \begin{pmatrix} a \\ \mu \\ \nu \end{pmatrix} - \tilde{\mathbf{U}} \right], \quad (31)$$

the solution (a^*, μ^*, ν^*) of which is given by:

$$\begin{pmatrix} a^* \\ \mu^* \\ \nu^* \end{pmatrix} = [\mathbf{Q}^T \mathbf{Q} + \varepsilon \mathbf{I}]^{-1} \mathbf{Q}^T \tilde{\mathbf{U}}. \quad (32)$$

IV. APPLICATION TO A HIGH PRECISION VOLTAGE REFERENCE BASED ON AN ELECTROSTATICALLY ACTUATED MEMS

In the sequel, we present some experimental results obtained by use of the method described above. The physical system under consideration is an electrostatically actuated MEMS devoted to the construction of a voltage reference of high precision and stability. From the electrical point of view, it is simply a variable capacitance in which the electrostatic force is opposed to the one of a mechanical spring between the two electrodes. So, there exists a so-called *pull-in voltage*, beyond which the mechanical force is no more able to balance the electrostatic one: this defines the reference voltage, which is determined by the only mechanical design of the MEMS [11], [8], [9].

For stability tests, the electrical environment of the MEMS is shown (in a simplified form) in Fig. 2. The DC voltage applied between the MEMS electrodes is chosen slightly less than the pull-in voltage. Variations of the ambient temperature generate variations of the electrical capacitance of the MEMS (around 10pF) and therefore variations of the measured AC voltage.

In order to evaluate the long time stability of the electrical characteristics of the device and its electrical environment, it is necessary to correct these voltage variations. However, due to the particular geometry of the MEMS whose desired electromechanical properties result from a complex design with very thin spring suspension of the mobile electrode (see Fig. 1) and also to the imperfections of the other associated devices (see Fig. 2), we can expect that large time constants are possibly involved in the influence of temperature on the AC voltage measurement. In such a case, the temperature cannot be uniform in the whole system if the ambient temperature variations are not sufficiently slow. Taking into account that very high precision is required, the dynamic correction presented above has therefore been implemented for a better correction. The efficiency of the method is illustrated by comparing the results with those obtained from standard static correction.

The measured data are shown in Fig. 3; the sample period is $\Delta t = 15\text{s}$. Significant variations of the AC voltages are visible; they mainly result from ambient temperature variations. For static correction, we have taken $n = 1$ (linear correction) or $n = 2$. For dynamic correction, $J = 6$ time constants $1/\xi_j$ have been used.

In Fig. 4, we can see both the measured data and a dynamic correction $a_0 - \sum_{i=1}^n a_i (T_k)^i - \sum_{j=1}^J \mu_j (\psi_{j,k} - T_k)$, where a_0 is the estimate of the exact (unknown) AC voltage U_0 . The correction is then subtracted to the measured data to get the so-called residual variations. These residual variations are shown in Fig. 5, 6, either non smoothed, or smoothed by means of a standard moving average filter. We can clearly see that a significant improvement is obtained from dynamic correction.

Evolutions of the temperature T and the "auxiliary temperatures" $\psi_j + \psi_{0,j}$ are shown in Fig. 7,8,9. In Fig. 10, we can see the contribution to these evolutions of the terms inherited from initial conditions, that is: $\psi_{0,j}(t_k) = \frac{\nu_j}{\mu_j} e^{-\xi_j t_k}$. Finally, Fig. 11 shows the differences between the auxiliary temperatures and T , that is the functions $\Psi_j = \psi_j + \psi_{0,j} - T$.

From a more quantitative point of view, we have the following results:

Mean measured AC voltage: 0.1040mV,
Standard deviation before correction of the AC voltage: $1.114 \times 10^{-3}\text{mV}$.

Standard deviation of the AC voltage after correction (mV):

	non smoothed	smoothed
stat. lin.	9.985×10^{-5}	4.911×10^{-5}
stat. nonlin.	9.780×10^{-5}	4.471×10^{-5}
dyn. lin.	6.769×10^{-5}	1.331×10^{-5}
dyn. nonlin.	6.725×10^{-5}	1.173×10^{-5}

Reduction of the residual variations of the AC voltage (smoothed corrected data):

stat. lin.	-27,3 dB
stat. nonlin.	-27.9 dB
dyn. lin.	-38.6 dB
dyn. nonlin.	-39.5 dB.

Improvement by use of dynamic correction versus static one:

linear	-11.3 dB
nonlinear	-11,6 dB.

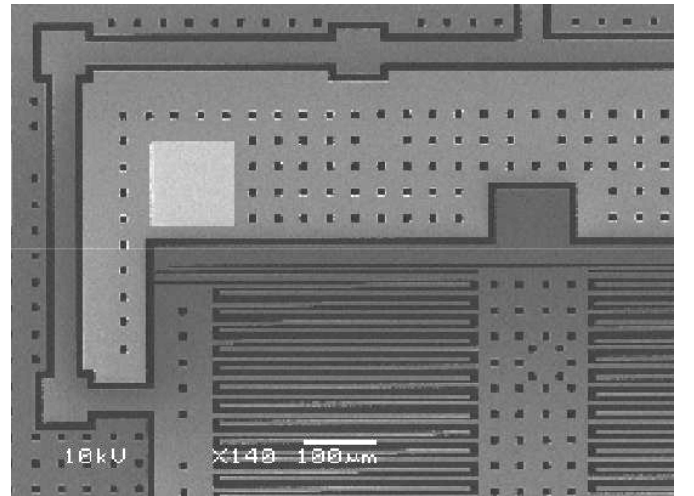

Fig. 1. The electrostatically actuated MEMS under consideration

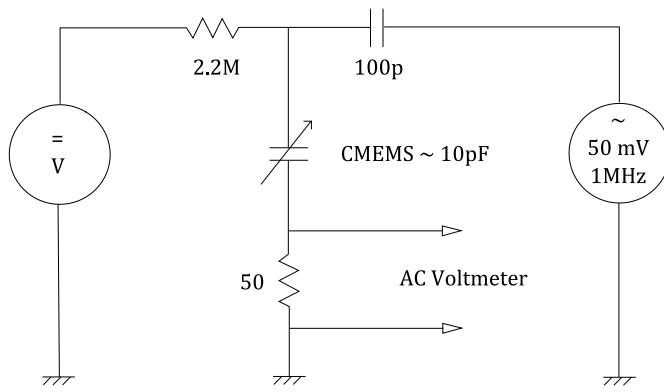

Fig. 2. Electrical environment of the MEMS for data acquisition

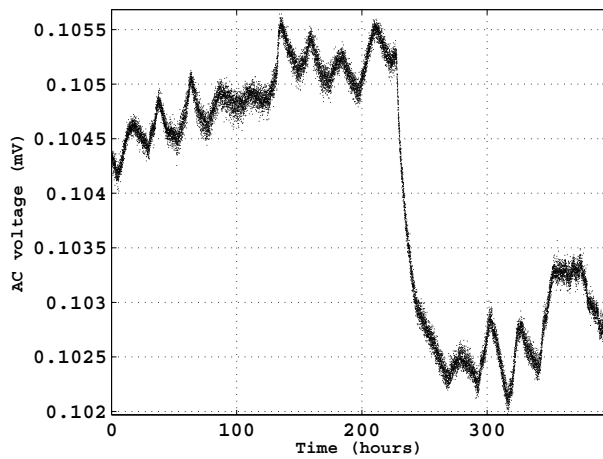

Fig. 3. Measured AC voltage

V. CONCLUSION

As clearly highlighted by these quantitative results, dynamic correction can in some cases generate significant improvements. Some residual variations remain after correction; they probably cannot be entirely induced by noises only. Indeed, great deviations of $\Psi_j(t)$ sometimes appear (see Fig. 11), which suggest that the only linear part of the dynamic correction is possibly no more sufficient in such cases. So, it could be judicious to involve higher order (nonlinear) terms of the series (21), in particular quadratic ones: $\mu_{2,j,j'} \Psi_j(t) \Psi_{j'}(t)$. This will be studied in a further work, with a new set of data devoted specifically to this problem.

REFERENCES

- [1] H. Camon, C. Ganibal, N. Raphoz, M. Trzmiel, C. Pisella, C. Martinez, S. Valette, *Solving functional reliability issue for an optical electrostatic switch*, Microsystem Technologies, Vol. 14, N. 7, July 2008.
- [2] H. Camon, F. Larnaudie, *Fabrication, simulation and experiment of a rotating electrostatic silicon mirror with large angular deflection*, 13th Int. Micro Electro Mechanical Systems (MEMS 2000), Miyazaki (Japan), Jan. 23-27, 2000, pp. 645-650.
- [3] C. Casenave, *Représentation diffusive et inversion opératoire pour l'analyse et la résolution de problèmes dynamiques non locaux*, PhD thesis, Toulouse (France), déc. 2009.

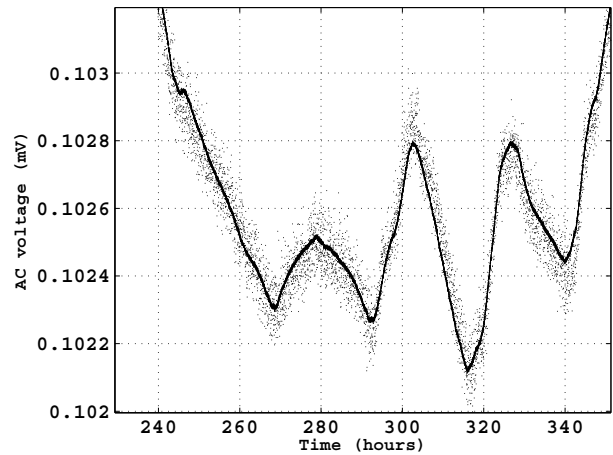

Fig. 4. Measured AC voltage (:), dynamic correction (—)

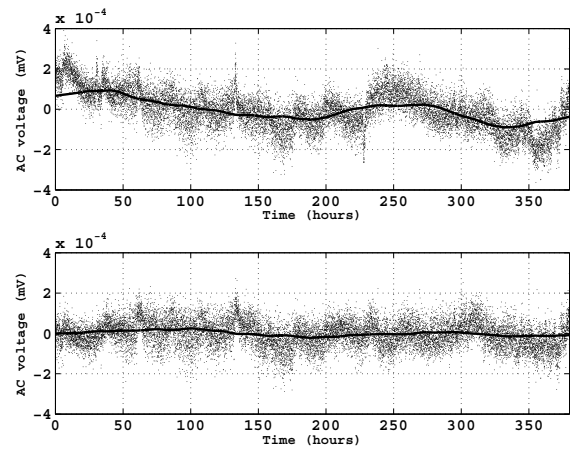

Fig. 5. Residual variations: with static correction (top), with dynamic correction (bottom); non smoothed (:), smoothed (—)

- [4] C. Casenave, G. Montseny, *Diffusive Identification of Volterra Models by Cancellation of the Nonlinear Term*, 15th IFAC Symposium on System Identification, SYSID 2009, Saint-Malo (France), July 6-8 2009, pp 640-645.
- [5] C. Casenave, E. Montseny, H. Camon, *Identification of a Nonlinear Dynamic Model of MEMS with Unstable Switching Zone*, IEEE Transactions on Control Systems Technology, accepted for publication, 2009.
- [6] C. Casenave, G. Montseny, *Identification of Nonlinear Volterra Models by means of Diffusive Representation*, 17th IFAC World Congress, Seoul (Korea), July 6-11, 2008, pp.4024-4029.
- [7] C. Casenave, G. Montseny, *Diffusive Representation and Applications*, submitted to 4th IFAC Symposium on System, Structure and Control, SSSC 2010, Ancona (Italy), 2010.
- [8] A. Kärkkäinen, N. Pesonen, M. Suhonen, A. Oja, A. Manninen, N. Tisnek, H. Seppä, *MEMS based AC voltage reference*, IEEE Trans. Instrum. Meas. 54, pp. 595-599, 2005
- [9] J. Kyynäräinen, A.S. Oja and H. Seppä, *Stability of microelectromechanical devices for electrical metrology*, IEEE Trans. Instrum. Meas. 50, pp. 1499-1503, 2001.
- [10] G. Montseny, *Représentation diffusive*, Hermès Science, 2004.
- [11] M. Suhonen, H. Seppä, A.S. Oja, M. Heinilä, I. Näkki, *AC and DC voltage standards based on silicon micromechanics*, CPEM'98 Conf. Dig, pp. 23-24, 1998.

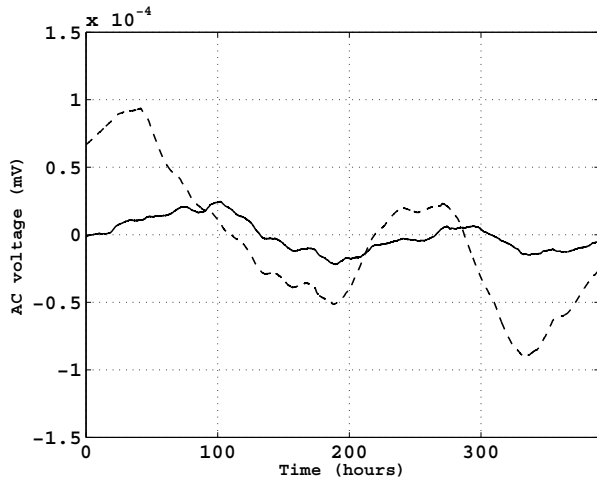

Fig. 6. Smoothed residual variations: static correction (- -), dynamic correction (-)

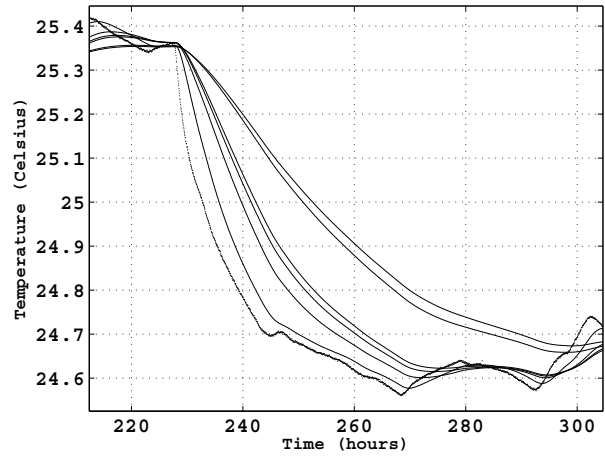

Fig. 9. Temperatures: $T(t)$ and $\psi_j(t) + \psi_{0,j}(t)$, $j = 1 : 6$ (zoom)

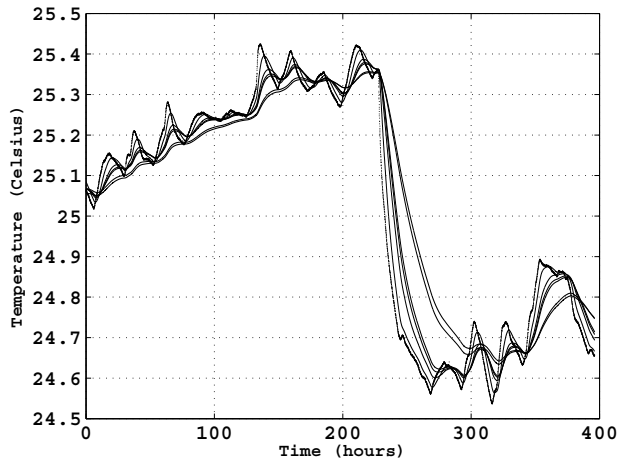

Fig. 7. Temperatures: $T(t)$ and $\psi_j(t) + \psi_{0,j}(t)$, $j = 1 : 6$

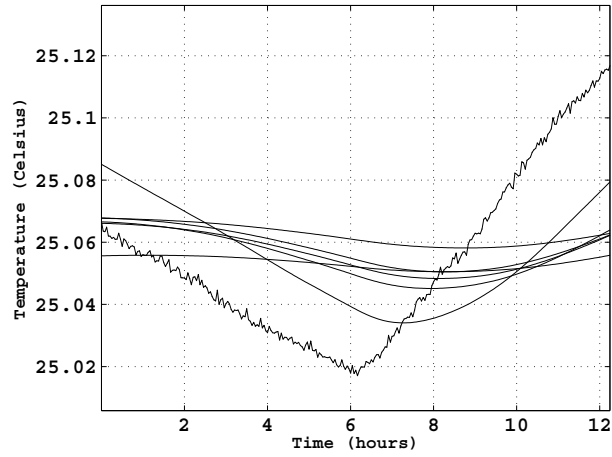

Fig. 10. Temperatures: $T(t)$ and $\psi_j(t) + \psi_{0,j}(t)$, $j = 1 : 6$ (zoom)

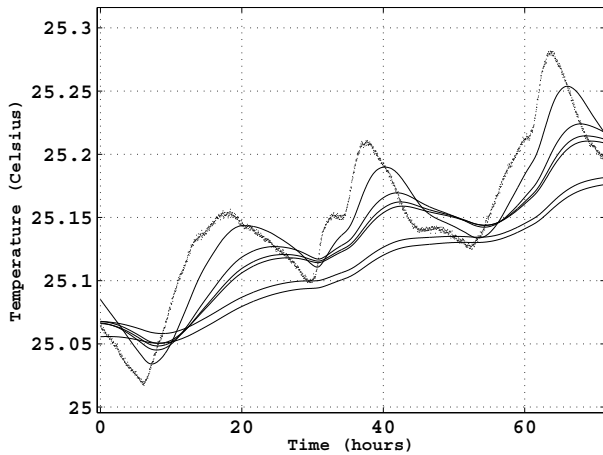

Fig. 8. Temperatures: $T(t)$ and $\psi_j(t) + \psi_{0,j}(t)$, $j = 1 : 6$ (zoom)

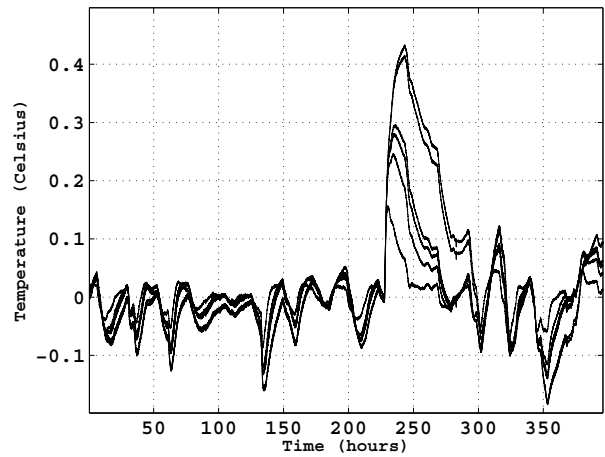

Fig. 11. Dynamic differences of temperatures: $\Psi_j(t) = \psi_j(t) + \psi_{0,j}(t) - T(t)$, $j = 1 : 6$