



HAL
open science

Potentialities of Usrc-Based Software Defined Radar Systems

Sandra Costanzo, Francesco Spadafora, Giuseppe Di Massa, Antonio Borgia,
Antonio Costanzo, Ginaluca Aloï, Pasquale Pace, Valeria Loscrì, Hugo
Oswaldo Moreno

► **To cite this version:**

Sandra Costanzo, Francesco Spadafora, Giuseppe Di Massa, Antonio Borgia, Antonio Costanzo, et al.. Potentialities of Usrc-Based Software Defined Radar Systems. Progress In Electromagnetics Research B, 2013, 53, 10.2528/PIERB13052904 . hal-00931209

HAL Id: hal-00931209

<https://inria.hal.science/hal-00931209>

Submitted on 15 Jan 2014

HAL is a multi-disciplinary open access archive for the deposit and dissemination of scientific research documents, whether they are published or not. The documents may come from teaching and research institutions in France or abroad, or from public or private research centers.

L'archive ouverte pluridisciplinaire **HAL**, est destinée au dépôt et à la diffusion de documents scientifiques de niveau recherche, publiés ou non, émanant des établissements d'enseignement et de recherche français ou étrangers, des laboratoires publics ou privés.

POTENTIALITIES OF USRP-BASED SOFTWARE DEFINED RADAR SYSTEMS

Sandra Costanzo^{1,*}, Francesco Spadafora¹, Giuseppe Di Massa¹, Antonio Borgia¹, Antonio Costanzo¹, Gianluca Aloï¹, Pasquale Pace¹, Valeria Loscri¹, and Hugo O. Moreno²

¹DIMES, Università della Calabria, Rende, CS 87036, Italy

²Facultad de Informatica y Electronica, Escuela Superior Politecnica de Chimborazo, Riobamba, Ecuador

Abstract—Software Defined Radar is the latest trend in radar development. To handle enhanced radar signal processing techniques, advanced radars need to be able of generating various types of waveforms, such as frequency modulated or phase coded, and to perform multiple functions. The adoption of a Software Defined Radio system makes easier all these abilities. In this work, the implementation of a Software Defined Radar system for target tracking using the Universal Software Radio Peripheral platform is discussed. For the first time, an experimental characterization in terms of radar application is performed on the latest Universal Software Radio Peripheral NI2920, demonstrating a strongly improved target resolution with respect to the first generation platform.

1. INTRODUCTION

Software Defined Radar (SDRadar) system is a special type of very versatile radar in which operations and components, originally implemented using dedicated hardware (i.e., mixers, filters, modulators and demodulators), are developed in terms of software modules. This leads to many advantages such as:

- ability to create “multipurpose radar”;
- ability to reuse hardware;
- easy implementation of signal processing;
- considerable reduction of production costs.

Received 29 May 2013, Accepted 10 August 2013, Scheduled 21 August 2013

* Corresponding author: Sandra Costanzo (costanzo@deis.unical.it).

The flexibility of software based systems [1] and their easy adaptability make them useful for many different applications, as shown in [2] for radar context. Since the radar platform is completely software defined, it can easily switch between different operation modes by simply modifying both the transmitted waveforms and the signal processing tasks on the fly. In the last years, the development of this new open software and hardware technology has gained a great impact on the research community. Many scientists and researchers are focusing their attention on SDRadar systems and many testbed and applications have been developed by considering the Universal Software Radio Peripheral (USRP) motherboard [3] as hardware base, and *GNU Radio*, an open source software-defined radio project, as a software tool to implement very sophisticated, low cost SDRadar applications.

In particular, Zhang et al. propose in [4] a measurement system making use of a hybrid radar scheme with continuous wave frequency modulation and a pseudo-random code pulse techniques. They show the ability to obtain high precision information concerning the velocity of a vehicle, the distance, the direction and other information useful to improve the security in the automotive field. In [5], an experiment based on the usage of a SDRadar is conducted to implement a multifunctional software-defined unit well suited for radar sensor networks which can be used for range measurements, radar imaging and data communications. It shows important results in order to highlight the issues and the limitations related to the combination of the SDRadar with radar systems. In [6], the capability of the USRP technology is demonstrated in the realization of a passive radar by designing a low-cost DVB-T software defined system for coastal ship detection, whilst in [7] an experiment is considered which is based on the usage of a SDRadar to implement first a basic radar system and then a synthetic aperture radar, thus providing an advanced step towards the establishment of the concept of cognitive radar. More recently, the potential of SDRadar technology to obtain flexible and low-cost subsurface radar prototypes for the Ground Penetrating Radar (GPR) community, is investigated in [8], whilst a GNU Radio based software-defined Frequency Modulated-Continuous Wave (FMCW) radar, well suited for weather surveillance application, is implemented in [9] at a reduced cost and complexity.

As confirmed by all these works, the GNU Radio software tool has represented, up to now, the most common developing tool for SDRadar applications; however, very recently, the *Communication Engineering Lab (CEL)* at the Karlsruhe Institute of Technology (KIT) developed a software package within the *Simulink-USRP* project that enables owners of a USRP to build models in SimulinkTM for that

interface with the hardware in real time. This new approach supports many functionalities compared to GNU Radio and it allows an optimal function elaboration throughout MATLAB and Simulink tools, so that many challenging SDRadar applications can be realized, as confirmed by several new works [10, 11].

In particular, Fernandez et al. implement in [10] a SDRadar system able to transmit and receive chirp waveforms by using MATLAB and SimulinkTM to implement the logic blocks, to process the received data and calculate the target range. Finally, the work in [11] presents a measurement testbed for OFDM radar which uses USRPs as a front-end. Since it requires little power, it can thus be easily installed in vehicles to perform measurements for car-to-car or car-to-infrastructure applications.

Most of existing solutions discussed above are limited to assess demonstrative SDRadar concept, thus a real compact SDRadar prototype is generally missed. As a matter of fact, in [4, 5, 8, 9] only laboratory experiments are performed, and standard instrumentations, such as signal generator, mixer and coupler, are adopted to simulate the SDRadar platform. A true USRP-based testbed is discussed in [11], but a low range resolution is achieved, and a high direct coupling is produced, thus limiting the available dynamic range. In [6], a single preliminary experimental test is performed on a big ship, and the authors themselves declare to plane more experiments on smaller ships located at further distances, in order to give a reliable validation of the proposed approach. Furthermore, no verification of the radar range resolution is provided in [6]. Finally, in [7], the testing and configuration analysis of the prototype is missed and declared in progress by the same authors.

Starting from the above considerations and the outlined literature scenario, the present work proposes the implementation and testing of a low cost *P-band* SDRadar system for target detection by using a first generation USRP programmed through Simulink as a reference approach, then extending the analysis to a new more powerful USRP 2920, produced by *National Instruments* (USRP NI2920), in order to obtain an increased resolution in target detection. As a matter of fact, the inherited advantageous features in terms of low-cost and reduced bulk, due to the adoption of software tools for implementing all radar blocks, are particularly useful when working at the low frequency range, such as the P-band, largely adopted for foliage penetration radars, when high dimension components (with respect to the wavelength) and more sophisticated signal processing techniques are required. By adopting a SDRadar configuration, all hardware blocks and signal processing procedures can be implemented into a unique software tool,

thus obtaining a very compact radar system, whose operations can be also easily changed real-time to satisfy dynamic constraints. It is worth to remark that, even though an arbitrary existing or own-made platform can be adopted to realize the radar operations, the USRP motherboard has been used here only for illustrative purpose, also increasing the target range resolution by using a high speed port and/or implementing specific processing techniques.

The main improvements introduced in this work with respect to the solutions reported in literature can be summarized as follows:

- (i) a compact USRP-based SDRadar platform, including the implementation of all radar modules and operation (signal generation, modulation/demodulation, mixer, A/D and D/A conversion, signal processing) is completely realized through software, thus obtaining a true prototype able to work not only for laboratory purpose, with a versatile software implementation usable for various kinds of radar applications;
- (ii) an accurate radar range profile is obtained, with a negligible error in the reconstruction of positions when considering multiple target, thus significantly improved with respect to the existing examples [6, 11];
- (iii) a strong improvement of the radar range resolution from 75 m up to 6 m with respect to existing USRP-based examples [11] is obtained;
- (iv) specific outdoor experimental test (and not only laboratory experiments) are performed into real (noisy) environmental scenarios, thus demonstrating the high accuracy in the reconstruction of the radar range profile, even in the presence of multiple objects.

The remainder of the work is organized as follows. Section 2 briefly explains the USRP project, with a particular focus on the transmission and the reception signal paths. Section 3 describes the implementation of a SDRadar application on both USRP platforms. In Section 4, numerical results concerning the noise sensitivity characterization of USRP-based SDRadar platforms are presented to enhance the improved target detection capabilities of USRP NI2920. Section 5 discusses experimental results able to demonstrate the improved target resolution when passing from the first generation USRP to the new one developed by National Instruments. Section 6 illustrates an interesting application able to switch between two different radar modalities, with the discussion of successful indoor experimental results. Finally, conclusions are outlined in Section 7.

2. USRP PROJECT AND RADAR APPLICATION POTENTIALITIES

USRP is an open source project related to an electronic system for creating SDRadar applications. The USRP is the first device that can be interfaced with a PC through a software development toolkit such as GNU Radio or Simulink, thus making possible the creation of different SDRadar applications. The first USRP motherboard was planned by Matt Ettus at the “National Science Foundation” in 2006 [3]. Nowadays, four versions are available: USRP, USRP2, USRP N200 and USRP N210. In the last year, the National Instruments has realized three new boards, namely USRP 2920, 2921, 2922 which interface with the PC through Labview™. Table 1 shows the main differences between the first generation USRP and the last USRP NI 2920.

Table 1. Software and hardware specification USRP Vs. USRP NI 2920.

USRP	USRP NI 2920
GNU Radio or Matlab Simulink™	Labview
2 dual channel ACD converter at 64 MS/s	2 channels ADC, 400 MS/s
2 dual channel DAC converter at 128 MS/s	2 channels, 100 MS/s
1 USB 2.0 for PC interface	1 Gigabit Ethernet for PC interface
1 FPGA <i>Altera Cyclone</i> (EP1C12 Q240C8)	<i>Xilinx Spartan-6</i>

2.1. Signal Behavior in a Transmission Path

In the first generation USRP the transmission waveform is generated by a PC through a software (GNU Radio or Simulink), then the signal is sent to the USRP by a USB buffer. Once inside the USRP, the signal is directed to the FPGA through another buffer with FIFO policy, where the interpolation operations are performed. After that, the waveform is converted from digital to analog and transferred to the daughterboard.

2.2. Signal Behavior in Reception Path

The reception path behavior is analogous to that in transmission mode, but in opposite direction. The waveform affecting the target

is backscattered and received again by the radar antenna; then, it is sent through the mixer which adapts the signal to the receive path, and subsequently it is amplified by a LNA and filtered by a LPF. At this point, the waveform is converted from analog to digital and transferred to the FPGA where the decimation operations takes place. The echo return is sent from USRP to the PC for the signal processing elaboration.

2.3. USRP Bandwidth Capacity and Radar Resolution

The USRP motherboard of first generation is equipped with an USB port supporting a maximum speed of 32 Mbyte/s [3]. In most radar applications, the USRP has to contemporarily transmit and receive, so the USB band halves to 16 Mbyte/s. In addition, the USRP works with complex samples (components I/Q of the signal); each sample is formed by 16 bit for the real part and 16 bit for the imaginary part, thus turning into a further band reduction to 8 Mbyte/s, as the useful signal is the only phase component. Since each sample is composed by 2 bytes (16 bit), the bandwidth B is equal to 2 MHz and this value can be used to determine the radar slant resolution according to the following formula, where the term c gives the free-space light velocity [12]:

$$\Delta R = \frac{c}{2B} = 75 \text{ m} \quad (1)$$

The Simulink tool used for the USRP interface allows the setting of the FPGA interpolation and decimation parameters, which control the data stream between the PC and the USRP; thus, with the aim of using the whole available bandwidth, we set the interpolation factor on the transmission side to 1024 (obtaining a sample rate of 125 Ksample/s) and the decimation factor on the receiver side equal to 16 (obtaining a sample rate of 4 Msample/s).

3. SDRADAR APPLICATION

In this section, the specific transmission and receiver configurations adopted to interface the USRP platforms with a PC are presented. Firstly, the Simulink model used to implement the SDRadar application on the first generation USRP is illustrated. In particular, Figures 1(a)–(b) show the transmission modules consisting of signal modulation generation and data sending to the USRP; on the receiving side, Figures 1(c)–(d) show the Simulink model related to the receiver and the relative subsystem for signal demodulation, digital filtering and data storage.

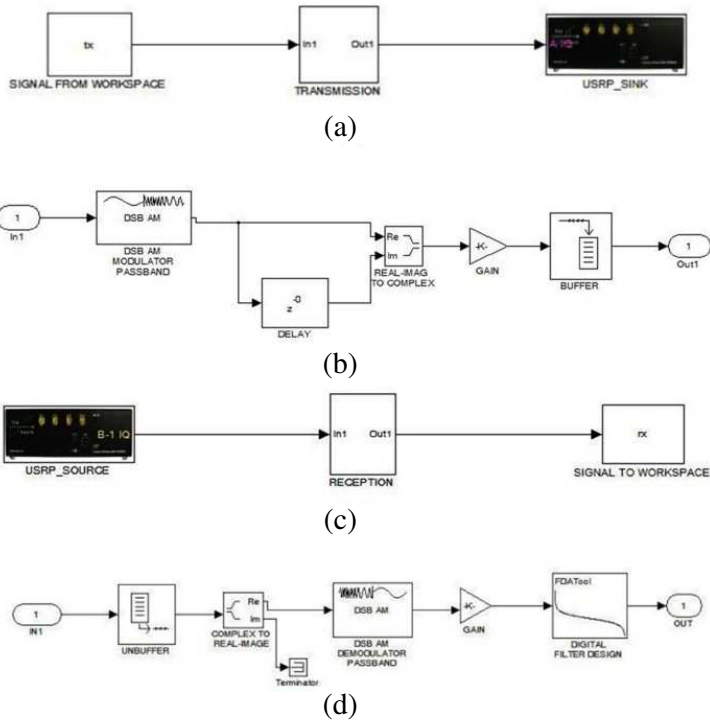

Figure 1. (a) Simulink model for the transmitter, (b) transmitting subsystem, (c) Simulink model for the receiver and (d) receiving subsystem.

In order to test the whole system, a SDRadar application is implemented which allows to control the USRP. The software leads to select the characteristic parameters of the pulse train used in transmission. It interfaces with the Simulink models previously described, starts the transmission and the reception through the USRP and, finally, performs simple signal processing operations. In particular, the software allows to:

- select the sample rate of the signal in transmission;
- select the amplitude of the pulse train;
- select the number of pulse in transmission;
- specify the period of the waveform;
- specify the duration of the pulse;
- display the transmitted and the received signal;
- measure the delay introduced by the system during the calibration;

- measure the delay between the transmitted and the received waveform according to the coordinates of the first significant sample of the first received pulse (mandatory operation to measure the distance of a target);
- measure the duration of the received pulse to make a comparison with the transmitted one (mandatory operation to verify the synchronism).

The initial screen interface of the developed SDR application on the USRP is presented in Figure 2.

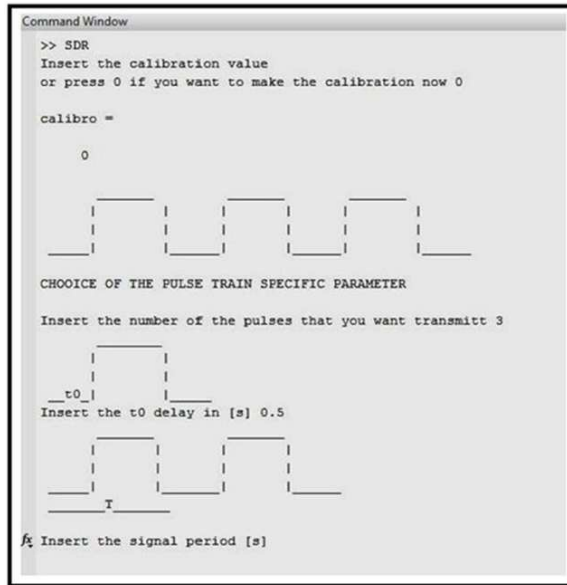

Figure 2. Simulink SDR application interface for USRP platform.

A similar scheme is implemented in LabVIEW code by adopting the USRP NI2920, based on a Gigabit Ethernet interface. In particular, the graphical interface shown in Figure 3 allows to select the operating frequency, the sample rate of the transmitted and received signals, the number of samples and the waveforms storage as well.

It is worth to remark that the system must be able to transmit and receive data with a perfect synchronization to ensure a correct operating. A digital data stream is said to be *time-coherent* when the digital signal represents accurately the counterpart of the analog signal. In this work, the synchronization issue is treated following our previous approach described in [13].

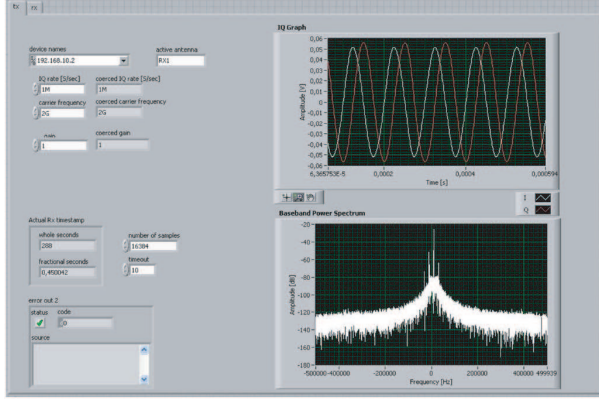

Figure 3. LabVIEW SDRadar application interface for USRP NI 2920.

4. NOISE SIMULATIONS: USRP VS. USRP NI2920

In order to properly identify the target detection capabilities and limitations of USRP-based SDRadar systems, numerical tests with Additive White Gaussian (AWG) noise are performed to simulate real scenarios with not negligible environmental noise. The first analysis is conducted on the USRP NI2920, by adopting the Stretch Processor Technique (SPT), which assumes a frequency-modulated signal [12] having the following expression:

$$s(t) = \cos\left(2\pi\left(f_0t + \frac{\mu}{2}t^2\right)\right), \quad 0 < t < \tau \quad (2)$$

where $\mu = \frac{B}{\tau}$ is the linear frequency-modulated coefficient, B is the system bandwidth, f_0 is the chirp start frequency and the chirp duration. In the presence of noise, the received signal $r(t)$ is given as:

$$r(t) = \alpha s(t - \Delta t) + w \quad (3)$$

where α is the attenuation factor due to the target radar cross section, the path loss and other losses introduced in the system; Δt is the propagation delay due to the target position, and w is the AWG noise with zero mean and variance equal to σ , simulated into the propagation channel. In the SPT, the target detection is performed by computing the spectrum energy related to the product between the transmitted and the received signals, namely:

$$A(f) = |F\{s(t) \cdot r(t)\}|^2 \quad (4)$$

where the term $F\{\dots\}$ denotes the Fourier transform operator.

The target range R is related to the peak frequency $f = f_p$ into (4) by the expression:

$$f_p = \frac{2BR}{c\tau} \quad (5)$$

where the term c represents the free space light velocity.

The analysis of USRP NI2920 performances in the presence of noise w is conducted in terms of parameter ρ defined as:

$$\rho = \frac{A(f)}{A(f_{\max})} \quad (6)$$

where:

$$A(f_{\max}) = \max[A(f)] : f \neq f_p \quad (7)$$

From definition (6), it is easy to deduce that a proper target detection can be performed for those noise parameters guaranteeing the condition $\rho > 1$. Various simulation tests are performed to identify the limit values of noise variance σ which assure a correct target position estimation. In Figure 4, an example of proper target detection is reported by illustrating the behavior of the spectrum energy (4) for a target positioned at a distance equal to 18 m, in the presence of AWG noise with a large variance value $\sigma = 60$. The signal peak at the correct position can be properly detected, as remarked by the red circle in Figure 4. For the illustrated case, the parameter ρ , given by the difference between the two highest peaks (in dB) is approximately equal to 27 dB, thus strongly greater than 1 in linear scale, as imposed by the condition outlined above.

Further simulations of parameter ρ for different values of noise variance are considered to obtain the curve reported in Figure 5, where

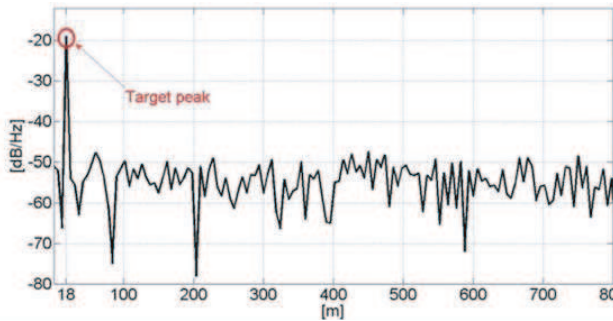

Figure 4. Spectrum energy behavior in the presence of AWG noise with variance $\sigma = 60$ (target position = 18 m).

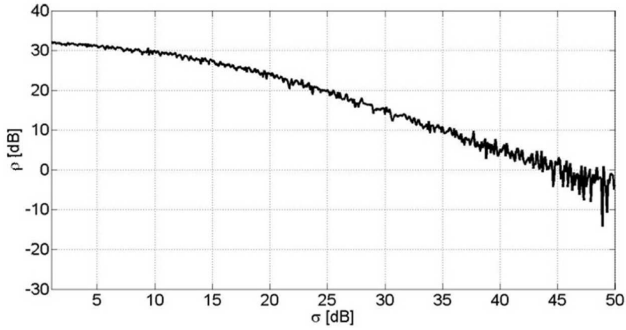

Figure 5. Behavior of parameter ρ vs. variance σ (target position = 18 m).

the value of ρ is properly maintained above 0 dB for realistic values of variance σ .

Similar results are obtained for test targets at different positions up to kilometers. To highlight the improved target detection capabilities of SDRadar systems based on USRP NI2920, a similar noise sensitivity analysis is conducted on the conventional first generation USRP. However, due to the high computational load, the SPT is practically inhibited, so in this case the analysis is performed in the time domain, by assuming a simple pulse of duration τ as transmitted signal $s(t)$, namely:

$$s(t) = \begin{cases} A & t < 0 < \tau, \\ 0 & \text{otherwise.} \end{cases} \quad (8)$$

The received signal $r(t)$ is the same as that defined in (3). The target detection is performed by computing the time delay between

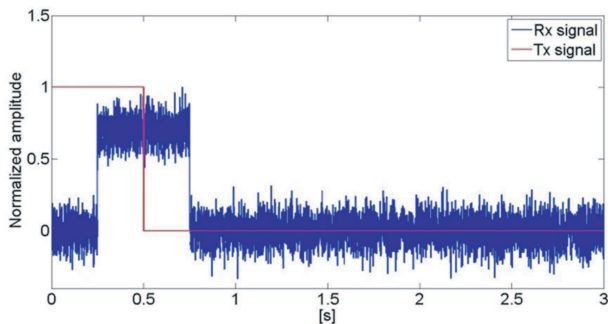

Figure 6. Tx and Rx signals in the presence of AWG noise ($\sigma = 30$).

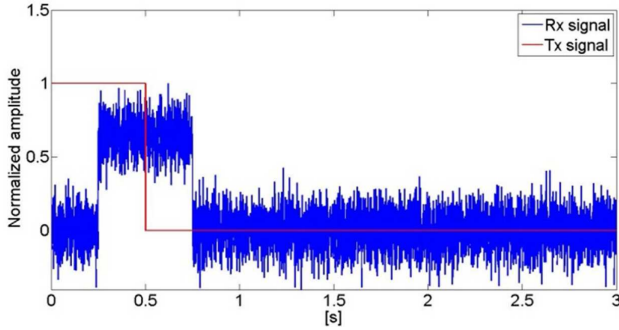

Figure 7. Tx and Rx signals in the presence of AWG noise ($\sigma = 60$).

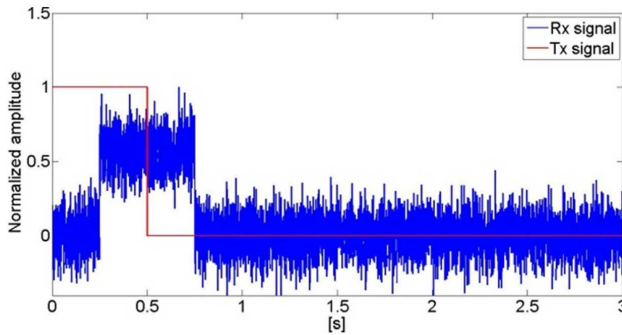

Figure 8. Tx and Rx signals in the presence of AWG noise ($\sigma = 90$).

the received and the transmitted signals, and the limitations of first generation USRP are investigated, as in the previous case, by considering various simulations for different target values of the noise variance σ , in the presence of the same test target of Figures 4, 5. Results reported in Figures 6, 7 and 8 show, as opposite to the USRP NI2920 case, that target detection cannot be easily performed yet for a variance value $\sigma = 60$ (about 17 dB), thus revealing much lower range estimation capabilities.

5. EXPERIMENTAL RESULTS — USRP VS. USRP NI2920

In order to test the applicability of USRP platforms as SDRadar systems, an experimental setup is assessed as depicted in Figure 9. A compact and broadband P-band antenna [14, 15] is adopted in the transmission path, while the standard antenna supplied with the USRP

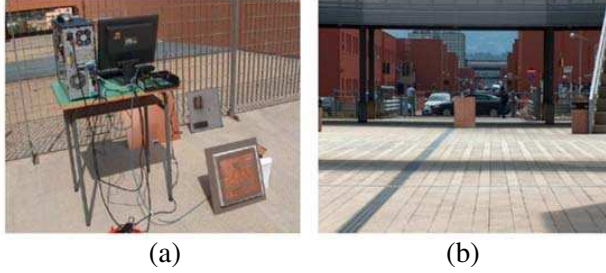

Figure 9. (a) SDR with first generation USRP and (b) reference target.

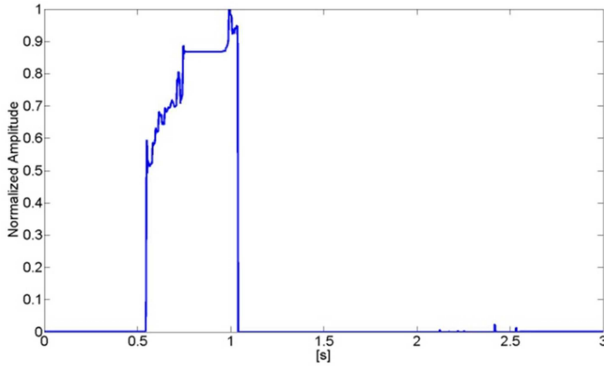

Figure 10. Received pulse with the first generation USRP for a target distance equal to 108 m.

kit is used in the receiving path.

The performances of the first generation USRP and those relative to the latest USRP 2920 by National Instruments are tested by adopting the platforms to detect the slant-range distance of a canonical target given by a metallic plate, as illustrated in Figure 9(b). The application described in Section 3 is configured to control the first generation USRP, and various measurements are performed by positioning the reference target at different distances from the transmitting/receiving platform. The exact and software retrieved target positions for different target distances are reported in Table 2, and an example of received pulse for a distance equal to 108 m is illustrated in Figure 10. Results summarized in Table 2 confirm a slant range resolution equal to 75 m, as obtained from (1) when imposing a bandwidth $B = 2$ MHz typical of the first generation USRP. Similar experimental tests are performed by adopting the latest USRP

Table 2. Exact and retrieved target position (first generation USRP).

Target Position [m]	Software position [m]
38	75
80	75
90	75
108	150

Table 3. Exact and retrieved target position with the USRP NI2920.

Target Position [m]	Software position [m]
$0 \div 6$	6
$6 \div 12$	12
$12 \div 18$	18

2920. At this purpose, a LabVIEW application code implementing the STP [12] is developed. Due to the Gigabit Ethernet interface, a wider bandwidth $B = 25$ MHz is provided in this case, thus obtaining from (1) a strongly improved slant range resolution equal to 6 m.

The theoretical resolution is confirmed by the experimental results summarized in Table 3, for different values of the real target distance. The relative signal peaks, properly retrieved by software, are illustrated in Figure 11.

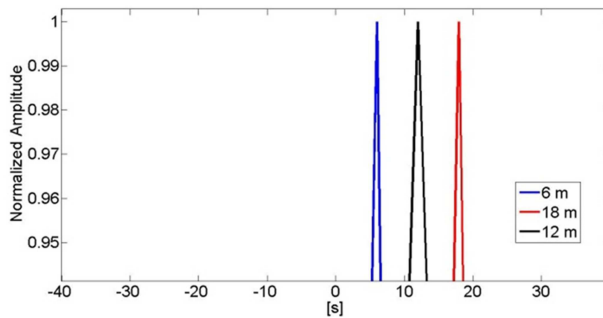

Figure 11. Retrieved signal peaks for different target positions.

6. USRP NI2920 APPLICATION: FMCW RADAR AND OFDM RADAR

A specific LabVIEW application is developed to simulate a multipurpose radar on the USRP NI2920 platform, able to switch between two different radar modalities, namely FMCW radar, based on a linear frequency sweeping (chirp) signal, and the Orthogonal Frequency-Division Multiplexing (OFDM), based on a frame-shaping waveform with different transmitted symbols associated to the different subcarriers [5, 6, 11]. Both radar modalities well work to receiving the echos from objects in the path of the signals wavefront, thus being able to reconstruct the objects position. In recent years, a particular focus has been addressed to the OFDM architecture, due to its high spectral efficiency and good performance in the presence of multipath scenarios [5].

In Figures 12–13, the LabVIEW interface relative to the two radar

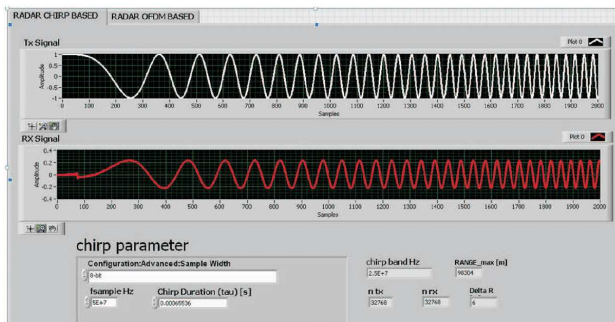

Figure 12. LabVIEW interface for the case of FMCW radar.

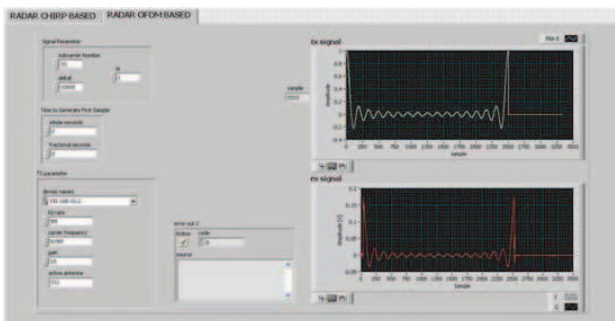

Figure 13. LabVIEW interface for the case of OFDM radar.

modalities is illustrated. In particular, in Figure 12 the transmitted and received chirp signals in the case of FMCW radar application are reported, together with the indication of the main chirp parameters, namely the bandwidth $B = 25$ MHz and the chirp duration $\tau = 655$ μ s, giving a radar range resolution equal to 6 m. Analogously, Figure 13 illustrates the behavior of transmitted and received signal in the case of OFDM radar modality, with the indication of the carrier frequency (915 MHz), the number of subcarriers (513) and the subcarrier distance (30 kHz).

Both examples reported in Figures 12–13 refer to experimental indoor test performed into the Microwave Laboratory at University of Calabria (Figure 14). At this purpose, a broadband log periodic antenna is used in both the transmission and the receiving paths, and planar metallic reflectors are adopted as reference target, positioned at different distances. As illustrated in Figures 15–16, the range profile of multiple target is reconstructed fairly well in both radar modalities, thus demonstrating the effectiveness of the implemented radar application.

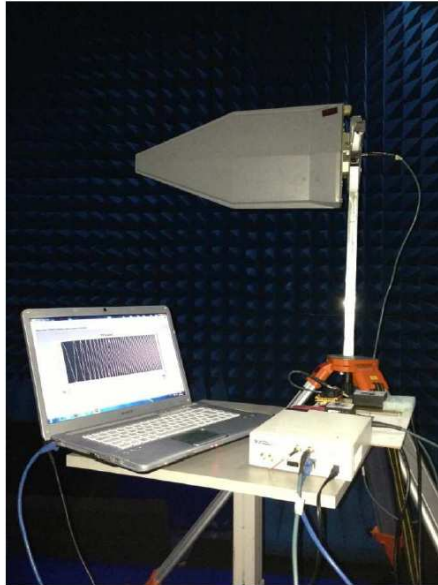

Figure 14. Photograph of indoor test setup (Microwave Laboratory — University of Calabria).

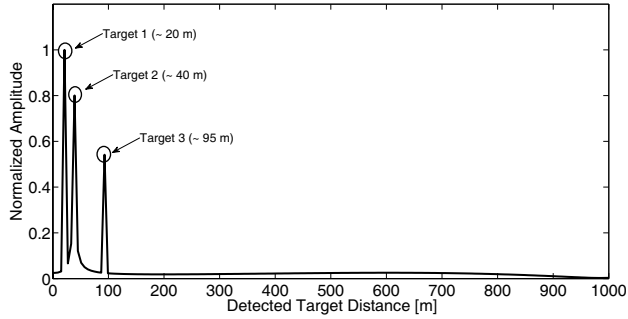

Figure 15. Range profile of multiple target for the case of FMCW radar.

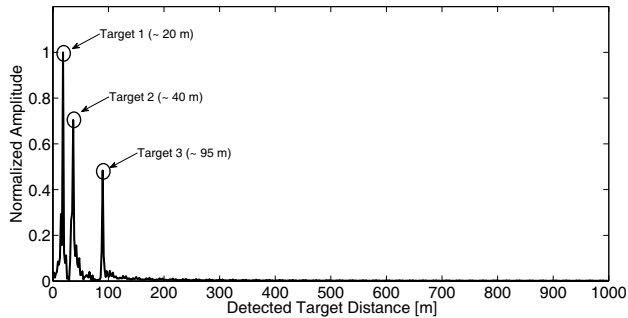

Figure 16. Range profile of multiple target for the case of OFDM radar.

7. CONCLUSIONS AND FUTURE DEVELOPMENTS

SDRadar systems give a high level of programmability and functionality compared to classical radar, thus appearing as a valid and low-cost solution to overcome hardware limits. They can be realized by using flexible, versatile, economic and compact software defined system such as the USRP; therefore, in this work, the features of software defined radio concept with respect to radar applications have been investigated by adopting the USRP platform to show the potential high resolution achievement. In particular, experimental validations have been performed to demonstrate an improved target resolution from 75 m to 6 m when passing from the first generation USRP to the latest USRP NI2920, due to the enhanced bandwidth. In this contribution, a first look has been provided into the potential application of USRP as software-based radar systems with appealing resolutions. For the first time, an experimental validation of the USRP NI2920 performances in

terms of radar applications have been provided. Future works will be addressed to the complete design of a compact multipurpose SDradar system.

ACKNOWLEDGMENT

This work has been carried out under the framework of PON 01-01503 National Italian Project “Landslides Early Warning”, financed by the Italian Ministry of University and Research.

REFERENCES

1. De la Morena-Álvarez-Palencia, C. and M. Burgos-Garcia, “Four-octave six-port receiver and its calibration for broadband communications and software defined radios,” *Progress In Electromagnetics Research*, Vol. 116, 1–21, 2011.
2. Debatty, T., “Software defined RADAR a state of the art,” *Proc. of 2nd International Workshop on Cognitive Information Processing (CIP)*, 253–257, Bruxelles, 2010.
3. Ettus, M., “USRP user’s and developer’s guide,” Aug. 2006, <http://www.ettus.com/>.
4. Zhang, H., L. Li, and K. Wu, “24 GHz software-defined radar system for automotive applications,” *European Conference on Wireless Technologies*, 138–141, Munich, Germany, 2007.
5. Garmatyuk, D., J. Schuerger, and K. Kauffman, “Multifunctional software-defined radar sensor and data communication system,” *IEEE Sensors Journal*, No. 1, 99–106, 2011.
6. Capria, A., M. Conti, D. Petri, M. Martorella, F. Berizzi, E. Dalle Mese, R. Soleti, and V. Carulli, “Ship detection with DVB-T software defined passive radar,” *IEEE Gold Remote Sensing Conference*, 2010.
7. Prathyusha, C., S. N. Sowmiya, S. Ramanathan, R. Soman, K. P. Amrita, V. V. Deepthi, M. Chinnam, and J. Nandhini, “Implementation of a low cost synthetic aperture radar using software defined radio,” *International Conference on Computing Communication and Networking Technologies (ICCCNT)*, 1–7, 2010.
8. Ralston, J. and C. Hargrave, “Software defined radar: An open source platform for prototype GPR development,” *IEEE International Conference on Ground Penetrating Radar (GPR)*, 172–177, Jun. 4–8, 2012.

9. Prabaswara, A., A. Munir, and A. B. Suksmono, "GNU Radio based software-defined FMCW radar for weather surveillance application," *International Conference on Telecommunication Systems, Services, and Applications (TSSA)*, 227–230, Oct. 20–21, 2011.
10. Fernandes, V. N. and J. Flynn, "Implementation of a radar system using Matlab and the USRP," California State University, Northridge, 2012.
11. Braun, M., M. Muller, M. Fuhr, and F. K. Jondral, "A USRP-based testbed for OFDM-based radar and communication systems," *Proceedings of 22nd Virginia Tech. Symposium on Wireless Communications*, Blacksburg, Jun. 2012.
12. Mahafza, B. R. and A. Z. Elsherbeni, *Simulations for Radar Systems Design*, CHAPMAN and HALL/CRC, 2003.
13. Aloï, G., A. Borgia, S. Costanzo, G. Di Massa, V. Loscrí, E. Natalizio, P. Pace, and F. Spadafora, "Software defined radar: Synchronization issues and practical implementation," *COGART International Conference on Cognitive Radio and Advanced Spectrum Management, ACM Internat. Conf. Proc. Series*, Article No. 48, Barcelona, Spain, 2011.
14. Costanzo, A., S. Costanzo, and G. Di Massa, "Design of a new broadband slot-loaded patch antenna," *Atti. Fond. G. Ronchi*, Vol. LXVII, No. 2, 225–230, 2012.
15. Costanzo, S. and A. Costanzo, "Compact slotted antenna for wideband radar applications," *Advances in Intelligent Systems and Computing*, Vol. 206, 989–996, 2013.