



HAL
open science

Horizontal Data Fusion for Integrative Modelling: the MedINRIA Fusion Toolbox

Benoît Bleuzé, Olivier Clatz, Pierre Fillard, Maxime Sermesant, Nicolas
Toussaint, Julien Wintz

► **To cite this version:**

Benoît Bleuzé, Olivier Clatz, Pierre Fillard, Maxime Sermesant, Nicolas Toussaint, et al.. Horizontal Data Fusion for Integrative Modelling: the MedINRIA Fusion Toolbox. 2010. hal-00813764

HAL Id: hal-00813764

<https://inria.hal.science/hal-00813764v1>

Submitted on 17 Apr 2013

HAL is a multi-disciplinary open access archive for the deposit and dissemination of scientific research documents, whether they are published or not. The documents may come from teaching and research institutions in France or abroad, or from public or private research centers.

L'archive ouverte pluridisciplinaire **HAL**, est destinée au dépôt et à la diffusion de documents scientifiques de niveau recherche, publiés ou non, émanant des établissements d'enseignement et de recherche français ou étrangers, des laboratoires publics ou privés.

Horizontal Data Fusion for Integrative Modelling: the MedINRIA Fusion Toolbox

B. Bleuzé, O. Clatz, P. Fillard, M. Sermesant, N. Toussaint*, J. Wintz
INRIA, Asclepios Team, Sophia Antipolis, France

1 Introduction

The Virtual Physiological Human research aims at integrating in computational models an extensive representation of the human body. Given the numerous phenomena interacting in such a complex living system, several different modalities of observation are needed in order to gather information on these phenomena. Moreover following up on the time evolution implies comparing data at different points in time. Finally, superposition of simulated volumes and acquired data is also a needed tool. All these needs require a so called "Horizontal Data Fusion" which registers in the same spatial coordinates different datasets. The most active area of research on horizontal data fusion is medical image processing. Medical images come from a larger and larger variety of modalities, and the number of image types for a single modality increases just as fast. However, the problems linked to that explosion of data and the need to put them together is that each registration algorithm has its own input/output formats, graphical user interface and visualisation. Thus, its use by a non-expert is challenging and the combination or comparison of such algorithms is difficult. Therefore, there is a need for a standard in horizontal data fusion.

The aim of our project at INRIA within the Virtual Physiological Human Network of Excellence¹ is to provide a toolbox enabling the visualisation and the aggregation of data fusion tools and algorithms: Medinria-fusion². Through the use of a core/plugin architecture, it explores solutions to make it easy for researchers to import their own tools, wrap them around a single application or ex-

*N. Toussaint is now with the King's College London, Division of Imaging Sciences, St Thomas' Hospital

¹<http://www.vph-noe.eu/>

²<http://www-sop.inria.fr/asclepios/projects/noe/>

change them between applications supporting the same framework. That attempt at a universal solution is a step towards standardisation of the exchange of algorithms. Standardisation calls for sustainability, maintainability.

The proposed framework can also help quantitative and qualitative tests of functionally similar methods. Medinria-fusion is a demonstrator that implements a registration algorithm, using the API we propose as an open framework. This software allows to visualise several formats of images (among them is DICOM).

2 Architecture

Medinria-fusion demonstrates the viability of a core/plugin architecture developed at INRIA. The visualisation code takes advantage of the work done in earlier versions of MedINRIA 1.x [1] and vtkINRIA3D [2].

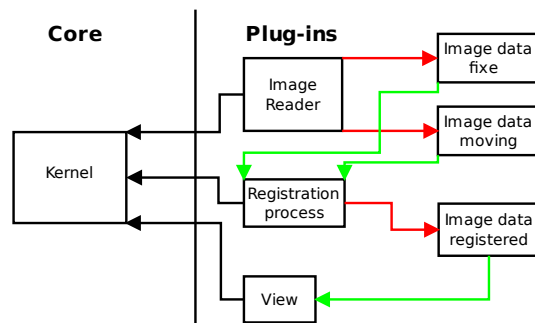

Figure 1: General architecture for registration algorithms within the MedINRIA framework (inputs are green, output red).

Figure 1 describes the general architecture. The

kernel (or core) provides an abstraction layer allowing the interaction between data, processes and views. A plug-in is an implementation of a data reader, writer, process or view. Registration algorithms are typical processes. Data are inputs and outputs for processes, views consume Data as inputs as well. They use data such as ITK³ image objects loaded for instance from DICOM files through readers. Views can be a VTK⁴ view for instance, or any other viewer. Object factories take care of the instantiation. A typical registration algorithm takes two data inputs: a fixed image that will act as a reference, and a so called moving image on which the transformation will be applied. The output is a third data object: the estimated transformation. The plug-ins are interchangeable, and an affine transformation can be replaced with a non linear one by just switching the process objects, which are dynamic libraries, without any change to the remaining of the software.

A clear advantage of that abstraction layer delivered as an open API is that open and closed source plug-ins from different institutions or vendors can live together in the same execution environment without any trouble, as long as the licences allow linking to other programmes.

3 Demonstrator

The demonstrator, named MedINRIA-fusion is a subset of a larger platform called MedINRIA, developed at INRIA. MedINRIA-fusion builds on the architecture and GUI from MedINRIA and puts the framework through its paces by implementing registration tools within it. The programme imports and stores DICOM files. The intuitive and slick looking interface makes it easy to use, and also particularly appealing to clinicians thanks to its simplicity (see figure 2).

The algorithm used for this demonstrator is a simple rigid transformation estimation, based on the ITK registration framework. Different visualisation modes to evaluate the results are proposed, including the checker-board, alternating parts of each image. As an example result, figure 3 shows the multimodal registration of two MRIs (T1 and

T2 modes). Three representations have been implemented so far: side by side comparison, and alpha-blending or checker-board mixing of the two images.

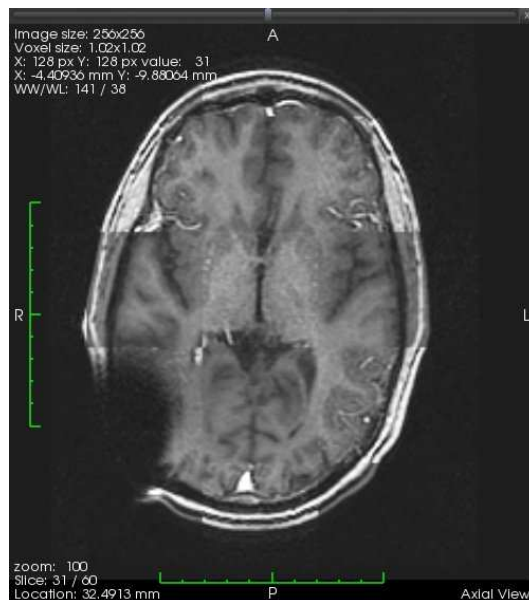

Figure 3: Checker-board fused MRIs (T1 and T2)

4 Perspectives

Within the VPH Toolkit, the objective of such toolbox is to aggregate the different tools existing in the community, thus it should suit the needs of other already existing algorithms to be wrapped as MedINRIA-fusion plug-ins. Moreover, by release a simple API and the software, the objective is also to attract more developers to the framework, so that any researcher can create his own plug-in.

Regarding the functionalities, the horizontal data fusion is also including other data supports, like meshes, so we plan to integrate fusion between meshes or between meshes and images in the next release.

5 Conclusion

Still in its infancy, this versatile framework showed an ease to import an existing algorithm, as well as an easy-to-use interface. The open API is our first

³<http://www.itk.org>

⁴<http://www.vtk.org>

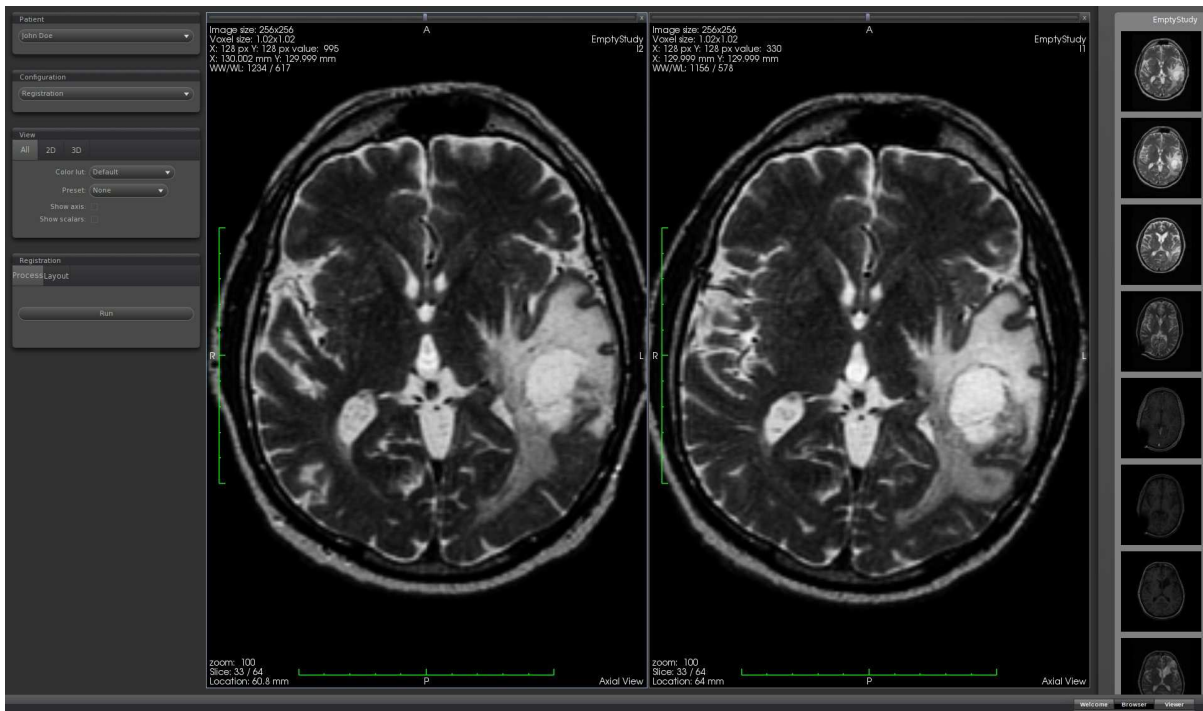

Figure 2: Medinria-fusion: viewer interface, while using the registration tools

attempt to federate researchers or developers under the same common language. More demonstrators are however needed to harden the concept.

References

- [1] N. Toussaint, J.C. Souplet, and P. Fillard. Medinria: Medical image navigation and research tool by inria. In *Proc. of MICCAI'07 Workshop on Interaction in medical image analysis and visualization*, Brisbane, Australia, 2007.
- [2] N. Toussaint, M. Sermesant, and P. Fillard. vtkinria3d: A vtk extension for spatiotemporal data synchronization, visualization and management. In *Proc. of Workshop on Open Source and Open Data for MICCAI*, Brisbane, Australia, October 2007.